



KING EDWARD VI  
HANDSWORTH GRAMMAR  
SCHOOL FOR BOYS



KING EDWARD VI  
ACADEMY TRUST  
BIRMINGHAM

**Year 9**

**2023 Mathematics 2024**

**Unit 13 Tasks – Part 1**

**DO NOT WRITE INSIDE**



KING EDWARD VI  
HANDSWORTH GRAMMAR  
SCHOOL FOR BOYS



KING EDWARD VI  
ACADEMY TRUST  
BIRMINGHAM

**Year 9**

**2023 Mathematics 2024**

**Unit 13 Tasks – Part 2**

**DO NOT WRITE INSIDE**





KING EDWARD VI  
HANDSWORTH GRAMMAR  
SCHOOL FOR BOYS



KING EDWARD VI  
ACADEMY TRUST  
BIRMINGHAM

**Year 9**

**2023 Mathematics 2024**

**Unit 13 Tasks – Part 3**

**DO NOT WRITE INSIDE**

## Contents Page

- 1 [2D Pythagoras' Theorem](#)
- 2 [Properties of 3D Shapes](#)
- 3 [Plans and Elevations](#)
- 4 [Volume and Surface Area of Prisms](#)
- 5 [Area and Volume Unit Conversions](#)
- 6 [Compound Measures](#)

# 1 2D Pythagoras' Theorem

# Fluency Practice

Use Pythagoras' theorem to find the length of the **hypotenuse** marked '?' in each of these **right-angled** triangles.  
*Drawings are NOT to scale.*

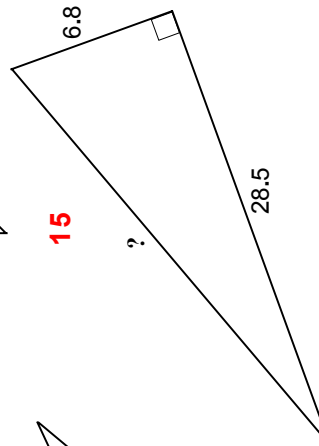
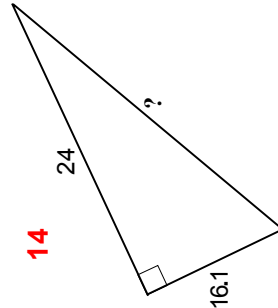
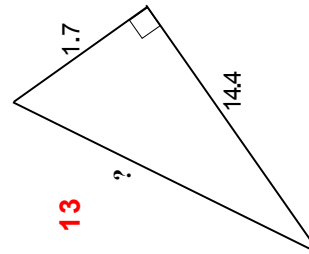
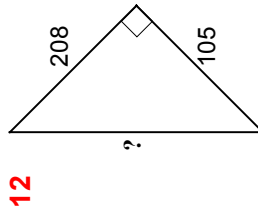
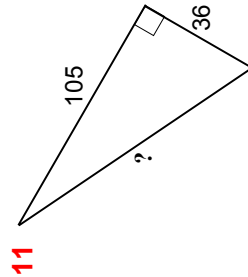
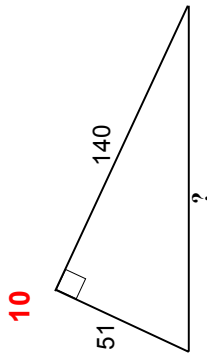
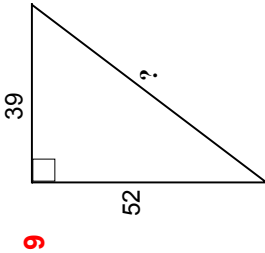
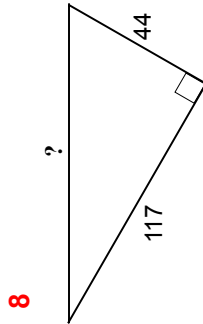
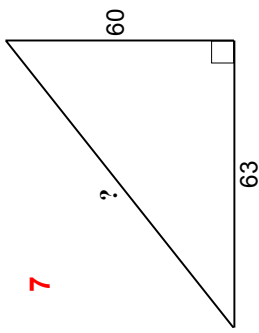
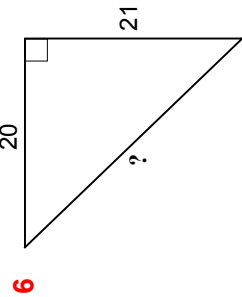
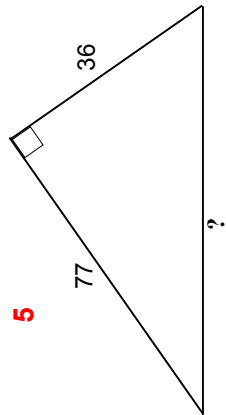
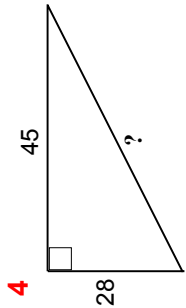
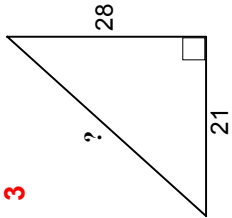
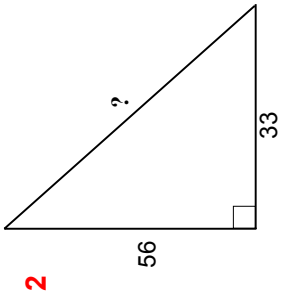
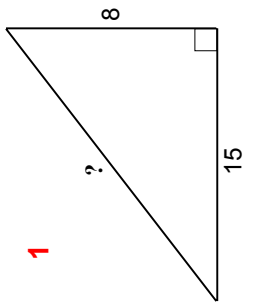

# Fluency Practice

## Finding the Length of the Hypotenuse using Pythagoras' Theorem

**(a)** Find  $x$  to 1 decimal place

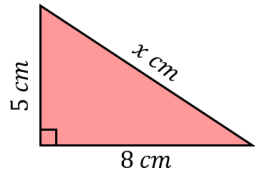

$$x^2 = 5^2 + 8^2$$

$$x^2 = 89$$

$$x = \sqrt{89}$$

$$x = 9.4 \text{ cm (1 dp)}$$

**(b)** Find  $x$

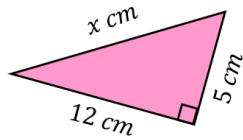

$$x^2 = 5^2 + 12^2$$

**(c)** Find  $y$  to 1 decimal place

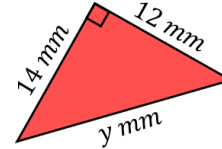

$$y^2 = 12^2 + 14^2$$

**(d)** Find  $x$

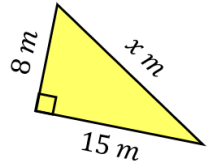

**(e)** Find  $y$  to 1 decimal place

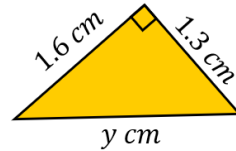

**(f)** Find  $x$  to 1 decimal place

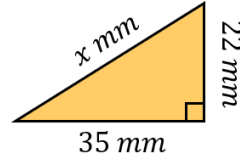

**(g)** Find  $x$  to 1 decimal place

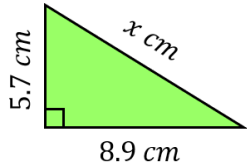

**(h)** Find  $y$

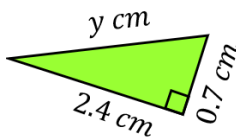

**(i)** Find  $y$  to 1 decimal place

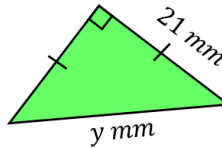

**(j)** Find  $x$ , leaving your answer as a surd

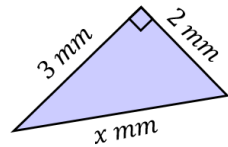

**(k)** Find  $y$ , leaving your answer as a surd

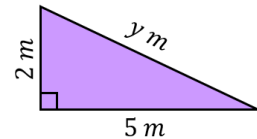

**(l)** Find  $x$ , leaving your answer as a surd

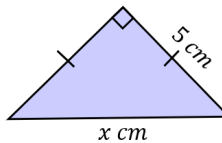

# Extension

(1)

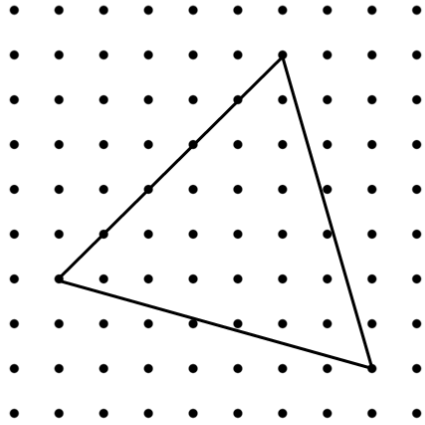

(2)

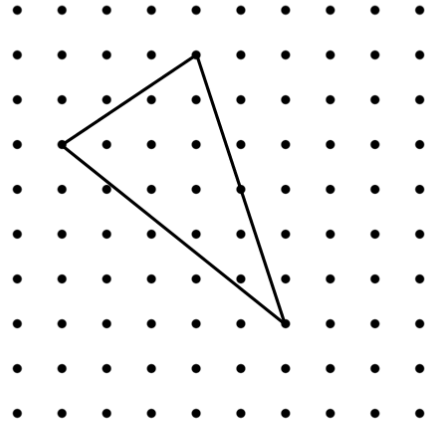

(3)

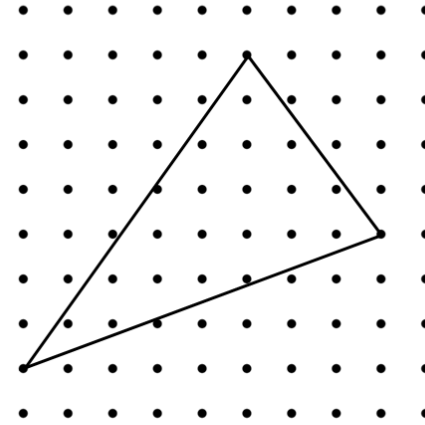

(4)

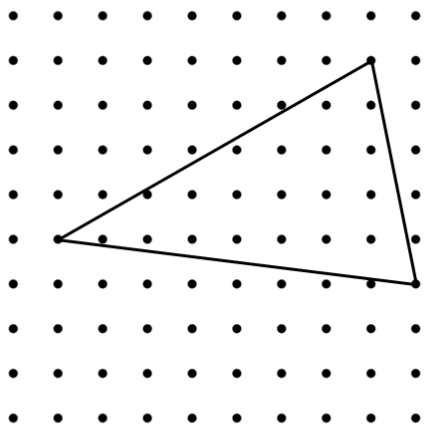

(5)

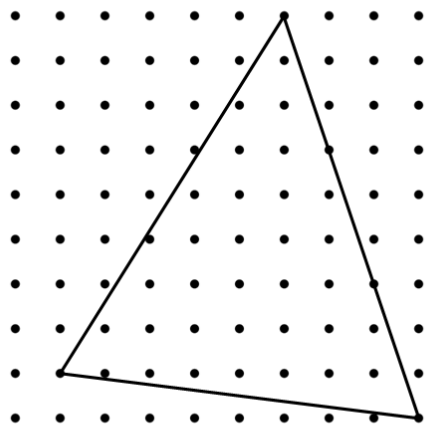

(6)

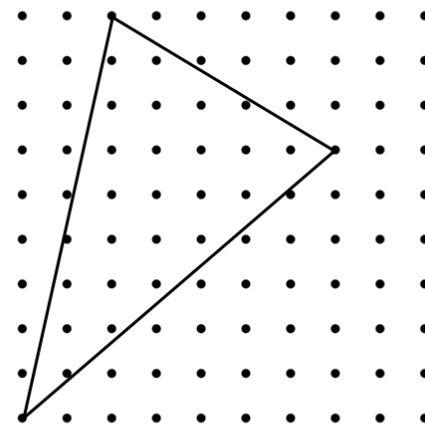

which of these are isosceles triangles?

# Intelligent Practice

Justify whether or not the triangles below are right-angled.

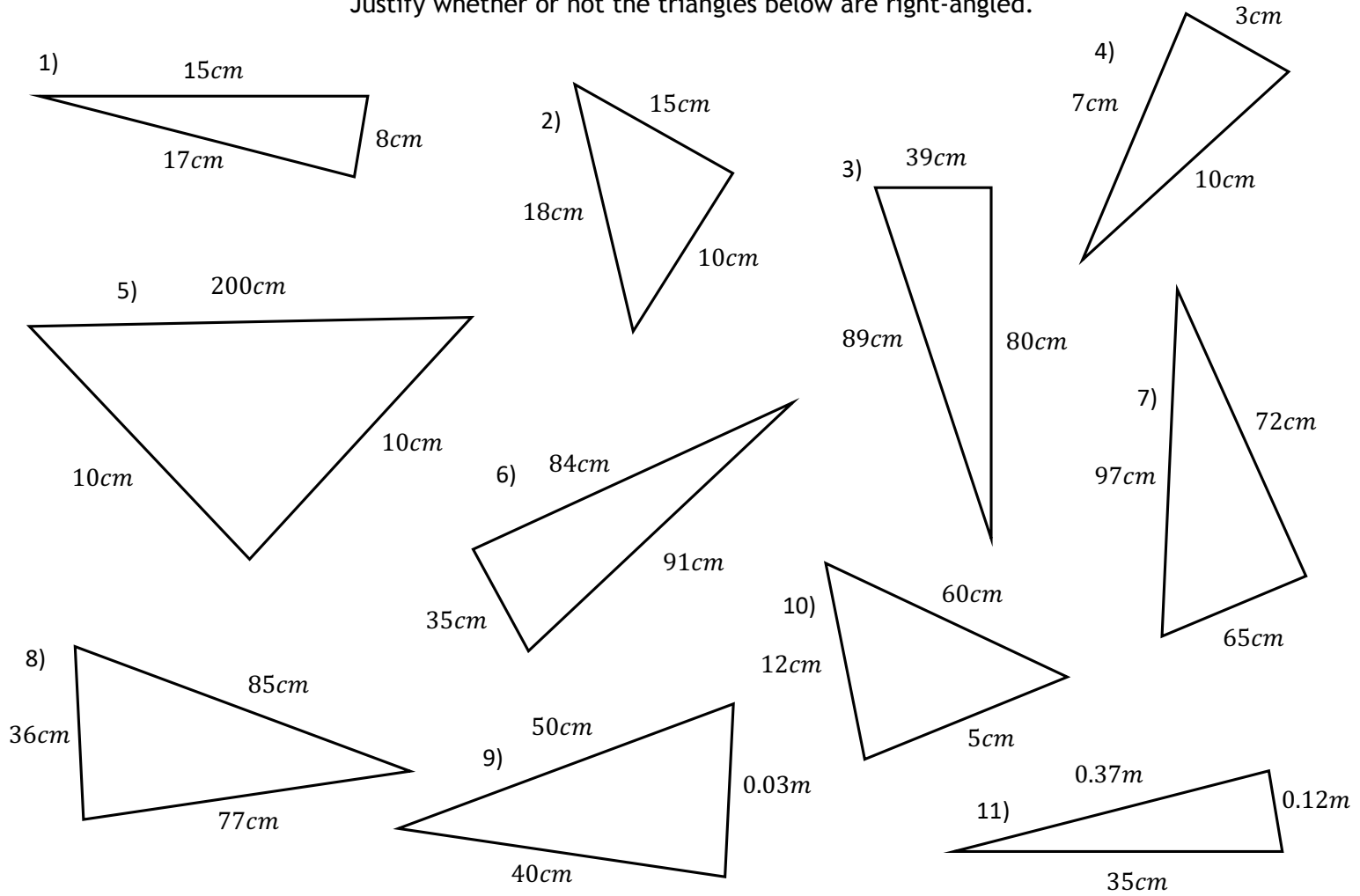

# Fluency Practice

Use Pythagoras' theorem to decide whether each of these triangles is right-angled or not.  
*Drawings are NOT to scale.*

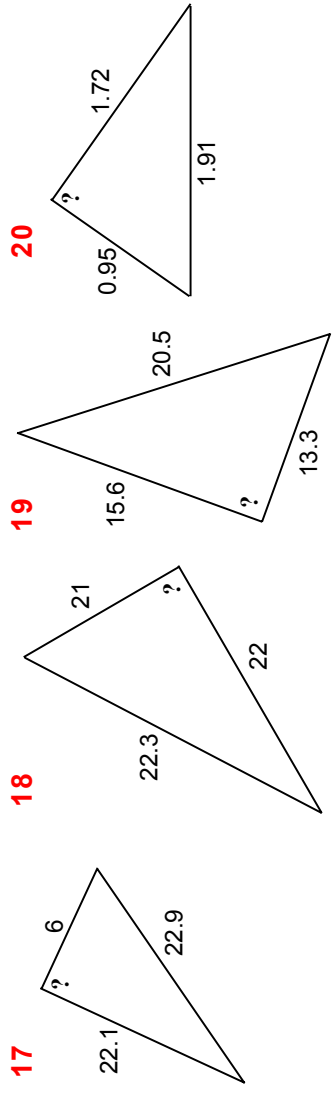
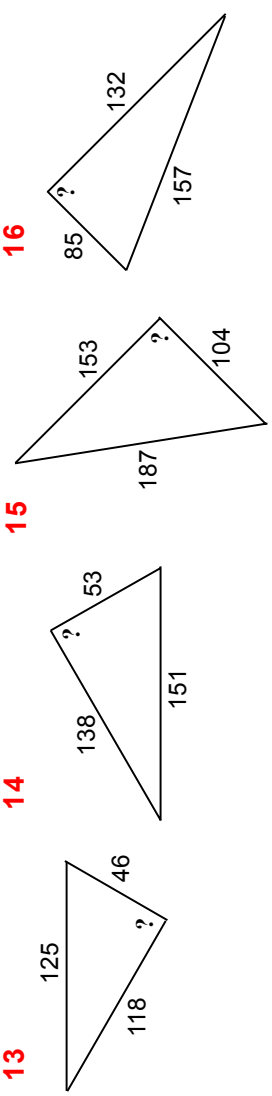
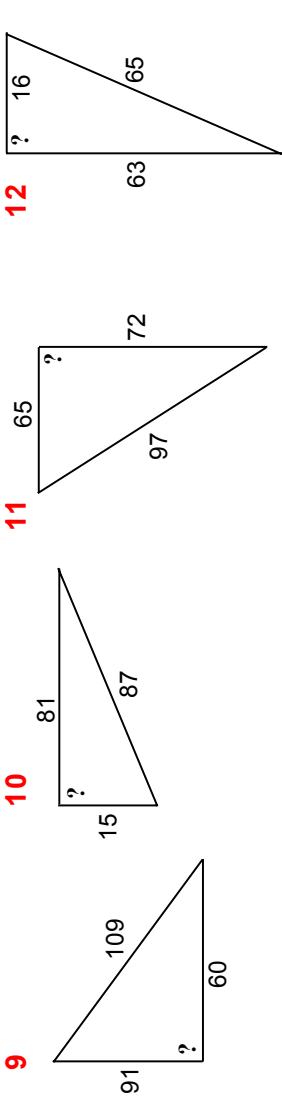
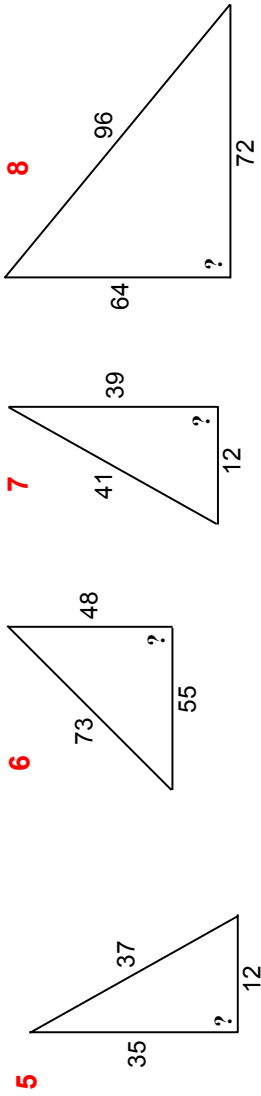
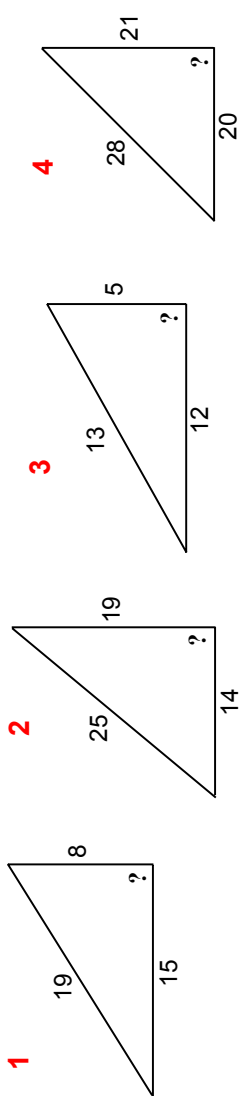



# Fluency Practice

Use Pythagoras' Theorem to decide whether each of these triangles is right-angled. Explain your reasoning.

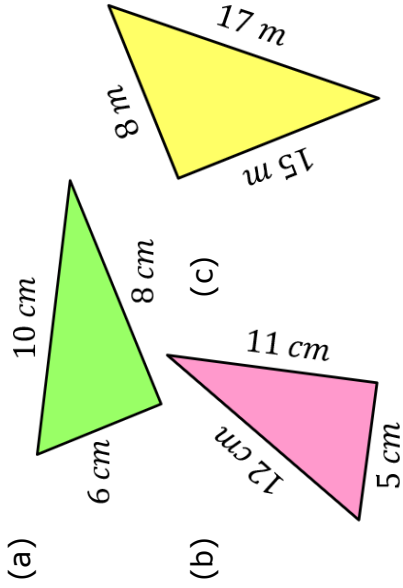

Decide whether each of these triangles is right-angled.

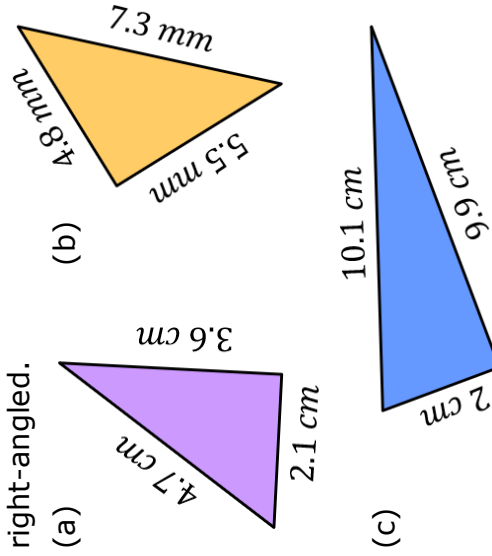

Which of these triangles is right-angled?

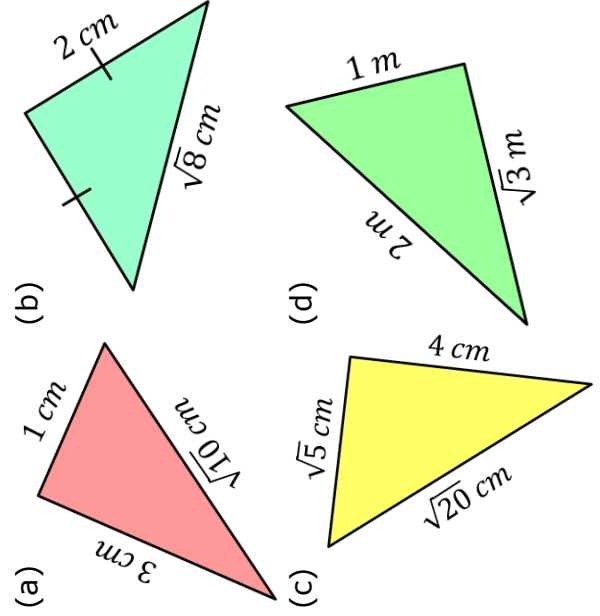

# Fluency Practice

1) Determine if the angles  $x$  is acute, obtuse or a right angle.

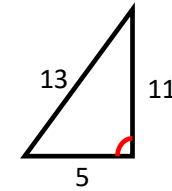
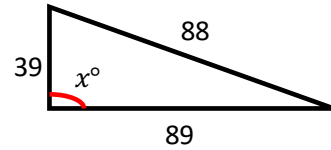
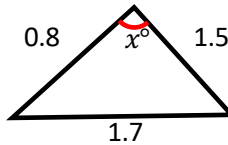
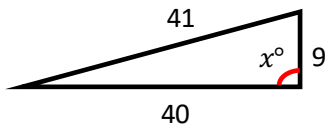
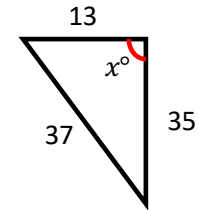
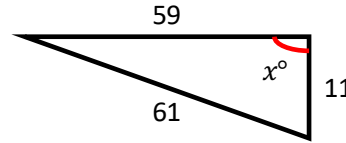
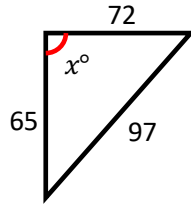
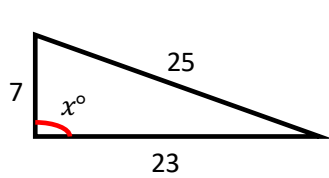

2) For each triangle, find a possible value of the missing side if:

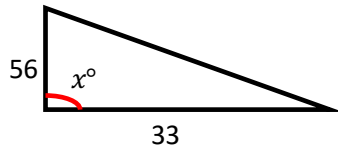

$x$  is a right angle

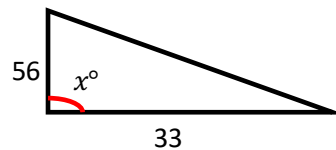

$x$  is acute

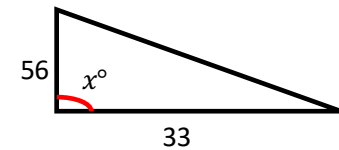

$x$  is obtuse

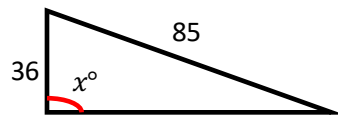

$x$  is a right angle

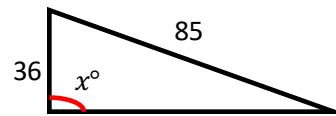

$x$  is acute

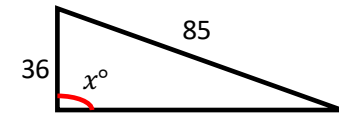

$x$  is obtuse

3) For which questions is there more than one answer? Explain.

# Fluency Practice

3) You are told that  $10^2 + 24^2 = 26^2$

Use this information to create four different questions where...

$x$  is acute

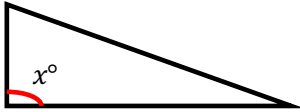

$x$  is acute

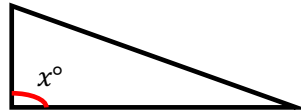

$x$  is obtuse

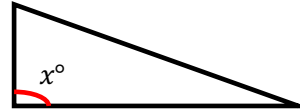

$x$  is obtuse

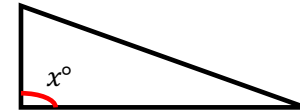

4) Try and complete these questions using reasoning and only using calculations to check

a) For this question one is acute, one is obtuse and one is a right angle. Determine which is which, explain your reasoning.

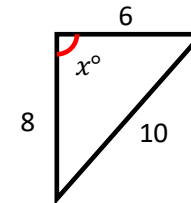
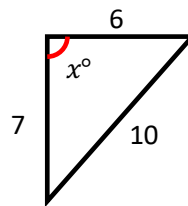
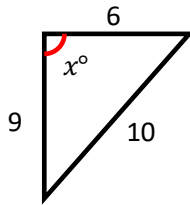

a) For this question two are obtuse and one is a right angle. Determine which is which, explain your reasoning.

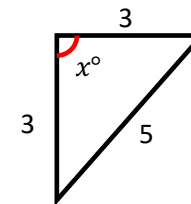
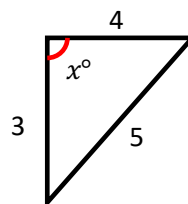
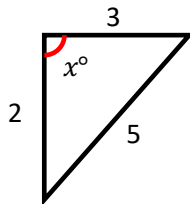

## Extension

Cristiano Ronaldo is jealous of Paul Pogba's dab, so Pogba tries to demonstrate that his dab is perfect. According to the book 'the Universal Declaration of the Rights of the Dab', a dab is only perfect if both triangles represented in the figure below are right angled.

Is Paul Pogba's dab perfect?

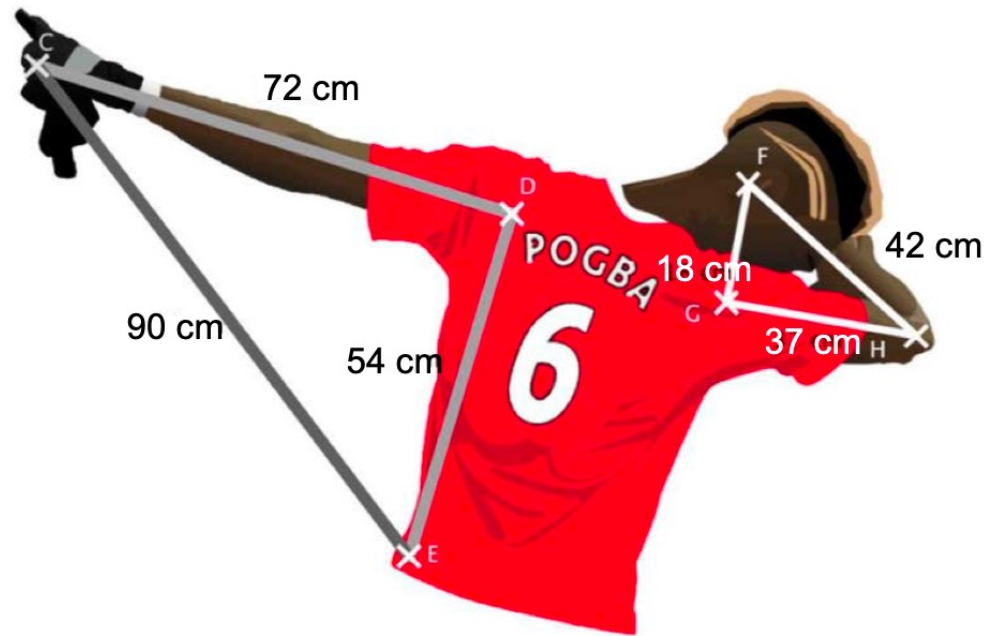



# Triangle Equations

Find **triangles** that satisfy these equations, with  $a \leq b \leq c$ .

Which ones are possible and which ones aren't?

When are they right-angled / obtuse-angled / acute-angled?

When are integer sides possible and when are they not?

What other forms can you invent and investigate?

$$a^2 + b^2 = c^2$$

$$a^2 + b^2 = c^2 + 1$$

$$a^2 + b^2 = c^2 - 1$$

$$a^2 + b^2 = 2c^2$$

$$a^2 + b^2 + 100 = c^2$$

$$a^2 + b^2 + c^2 = 100$$

$$ab = c^2$$

$$\sqrt{a} + \sqrt{b} = \sqrt{c}$$

$$a + b = c$$

$$a + b = c + 1$$

$$a + b = c - 1$$

$$\frac{1}{a} + \frac{1}{b} = \frac{1}{c}$$

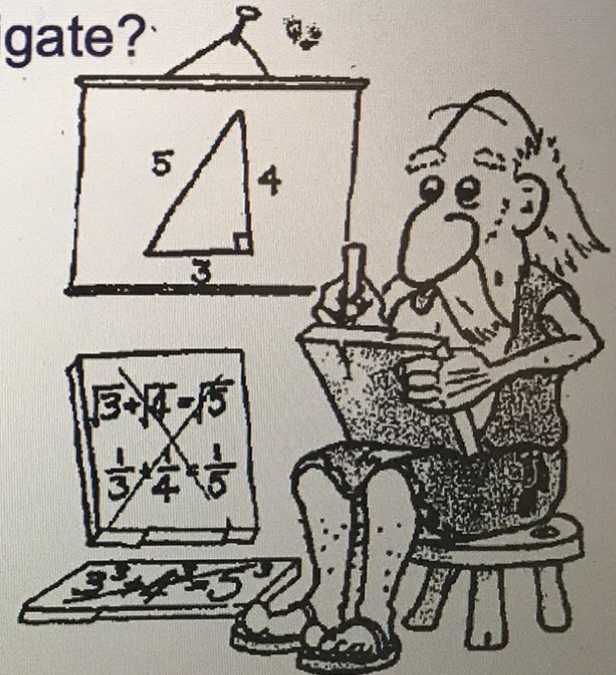

# Fluency Practice

## Finding the Length of a Short Side using Pythagoras' Theorem

**(a)** Find  $x$  to 1 decimal place

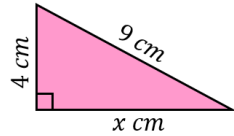

$$\begin{aligned} 9^2 &= x^2 + 4^2 \\ x^2 &= 9^2 - 4^2 \\ x^2 &= 65 \\ x &= \sqrt{65} \\ x &= 8.1 \text{ cm (1 dp)} \end{aligned}$$

**(b)** Find  $x$

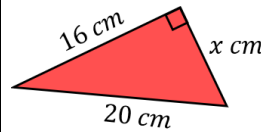

$$\begin{aligned} 20^2 &= x^2 + 16^2 \\ x^2 &= 20^2 - 16^2 \end{aligned}$$

**(c)** Find  $y$  to 1 decimal place

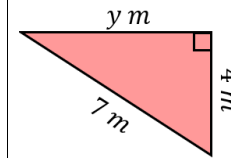

$$\begin{aligned} 7^2 &= y^2 + 4^2 \\ y^2 &= 7^2 - 4^2 \end{aligned}$$

**(d)** Find  $x$

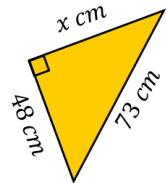

**(e)** Find  $y$  to 1 decimal place

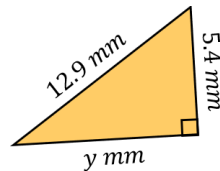

**(f)** Find  $x$  to 1 decimal place

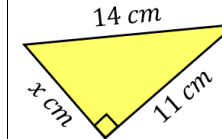

**(g)** Find  $x$  to 1 decimal place

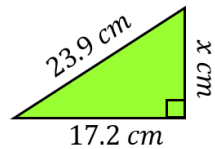

**(h)** Find  $y$

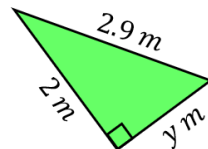

**(i)** Find  $y$  to 1 decimal place

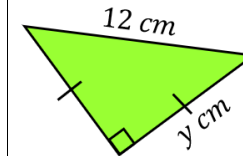

**(j)** Find  $x$ , leaving your answer as a surd

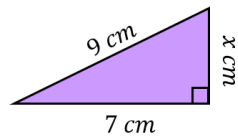

**(k)** Find  $y$ , leaving your answer as a surd

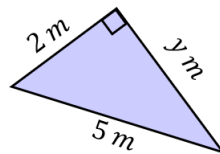

**(l)** Find  $x$ , leaving your answer as a surd

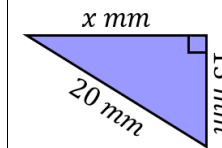

# Fluency Practice

Use Pythagoras' theorem to find the length of the edge marked **?**; **OR** decide whether the triangle is right-angled or not  
*Drawings are NOT to scale.*

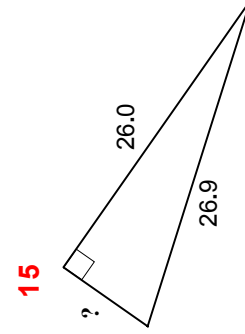
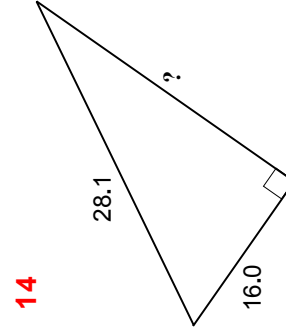
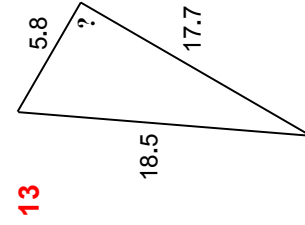
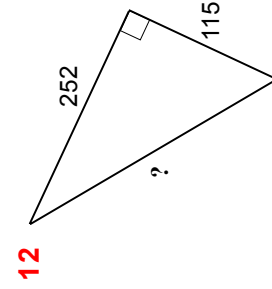
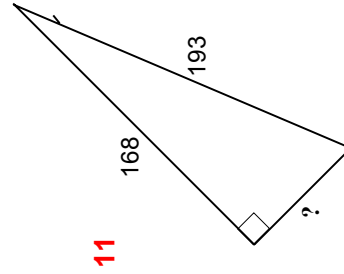
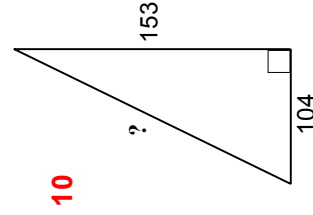
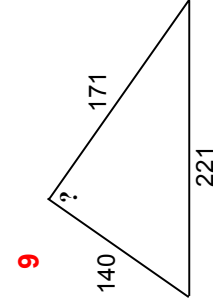
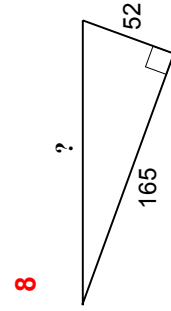
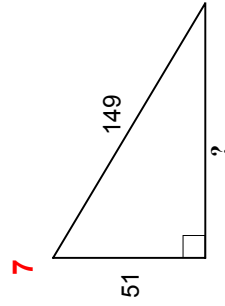
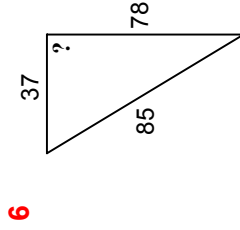
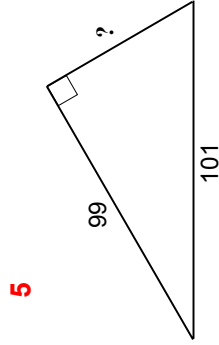
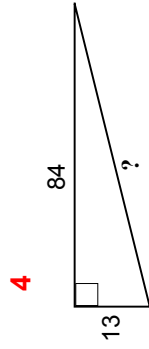
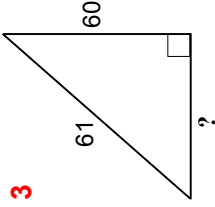
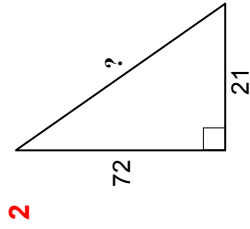
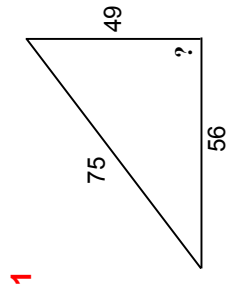

# Fluency Practice

Find the missing lengths & simplify your answers.

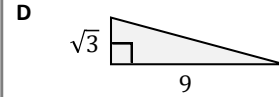
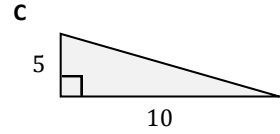
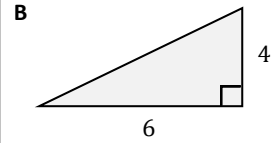
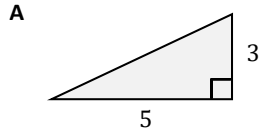

Diagrams not drawn accurately.

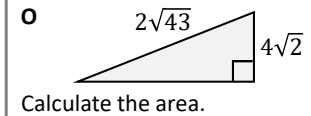
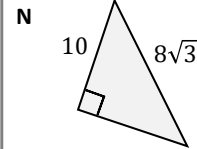
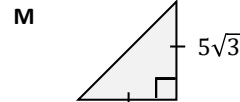
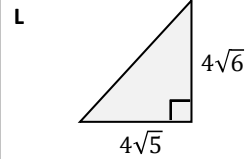
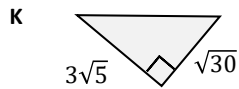
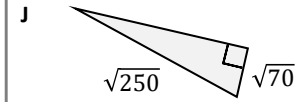
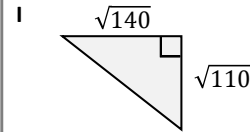
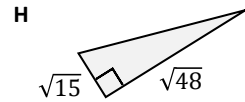
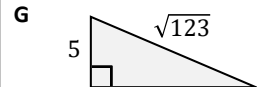
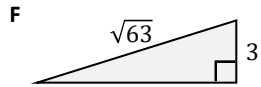
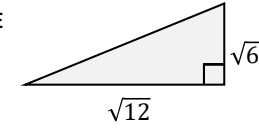

14 Answers	$3\sqrt{7}$	$3\sqrt{2}$	$5\sqrt{6}$	$\sqrt{34}$	$2\sqrt{23}$	$5\sqrt{5}$	$5\sqrt{3}$
	$2\sqrt{13}$	$4\sqrt{11}$	$2\sqrt{21}$	$5\sqrt{10}$	$7\sqrt{2}$	$6\sqrt{5}$	$3\sqrt{6}$



# Extension

generalising pythagoras surd families (i)

(1)

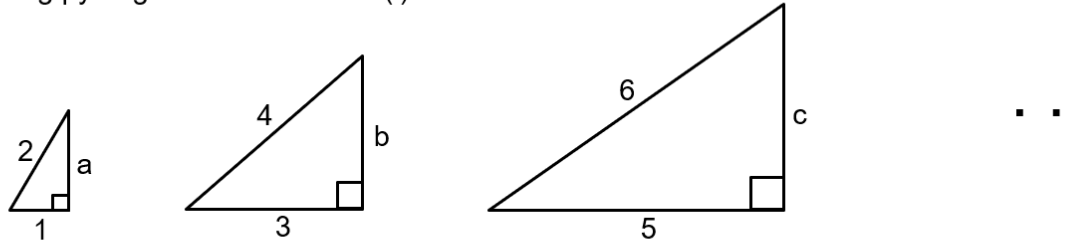

(2)

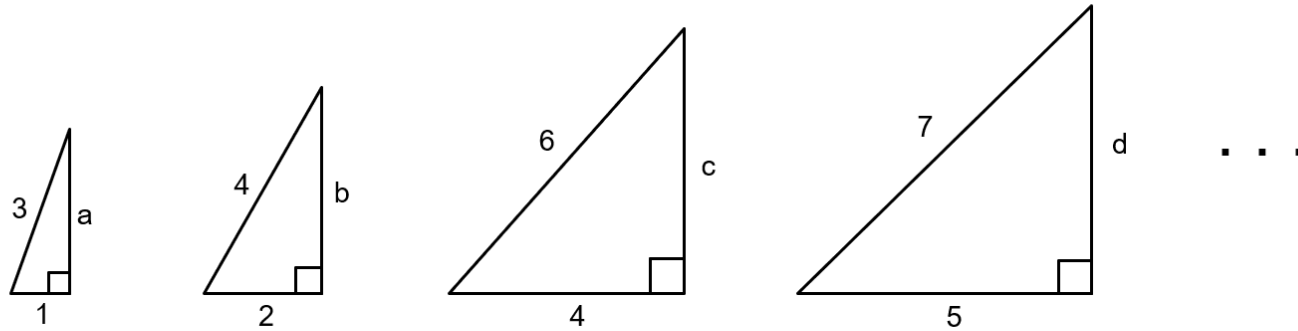

(3)

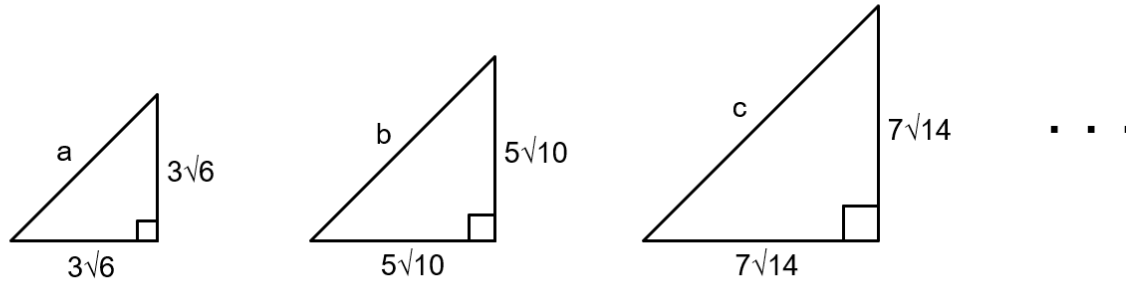

## More-Same-Less – Pythagoras

Instructions: Calculate the value of  $x$ . Then complete the remaining boxes trying to make the minimal change possible. On each triangle, state the size of all three lengths. Where decimals are needed, round to 2 decimal places.

**Value of hypotenuse**

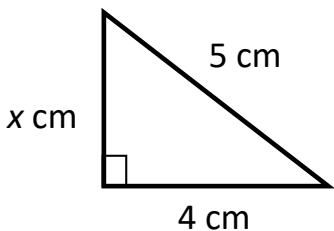

		Less	Same	More
Value of the height	More			
	Same			
	Less			

# Problem Solving

Match the cards to the side lengths of the right-angled triangles.  
Use each card once only. Diagrams are not drawn to scale.

## pythagoras puzzles

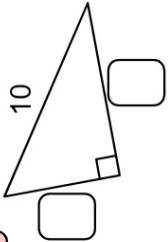
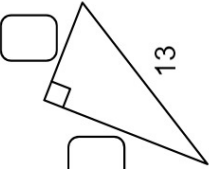
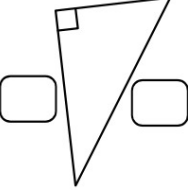
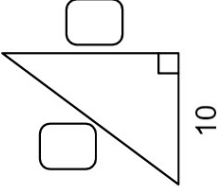
**A**

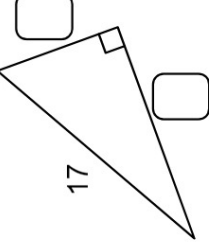

4 5    4 5    4 5  
5 6    5 6    5 6  
7 8    7 8    7 8  
8 12    8 12    8 12  
15 24    15 24    15 24  
24 26    24 26    24 26

**B**

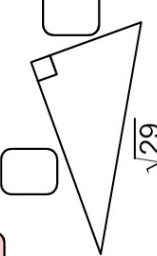
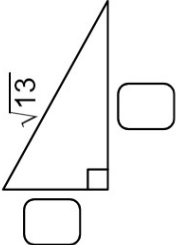
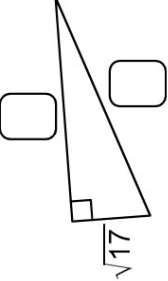
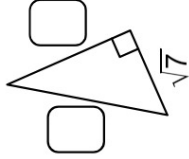
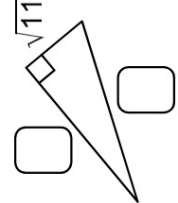
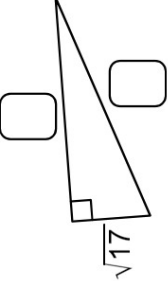
2 2    2 2    2 2  
3 3    3 3    3 3  
4 4    4 4    4 4  
5 5    5 5    5 5  
6 6    6 6    6 6  
8 8    8 8    8 8  
9 9    9 9    9 9

**C**

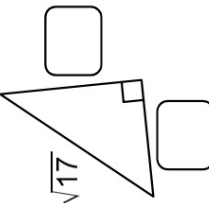
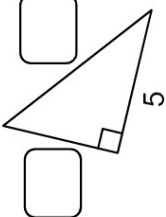
		
--	---	---

3 3    3 3    3 3  
2√2 2√2    2√2 2√2    2√2 2√2  
√11 √11    √11 √11    √11 √11  
4 4    4 4    4 4  
2√3 2√3    2√3 2√3    2√3 2√3  
√37 √37    √37 √37    √37 √37

# Fluency Practice

Round answers to 2dp

Question 1: Calculate the length of the line joining the points A and B.

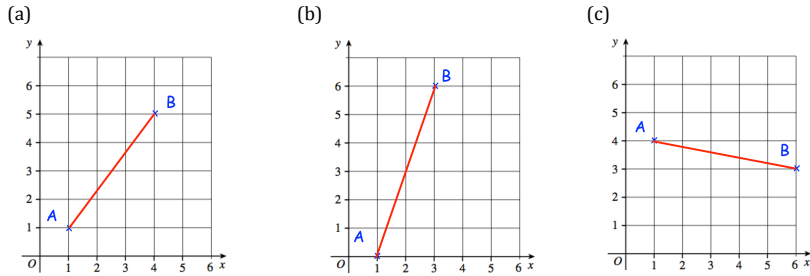

Question 2: Calculate the length of the line joining the points A and B.

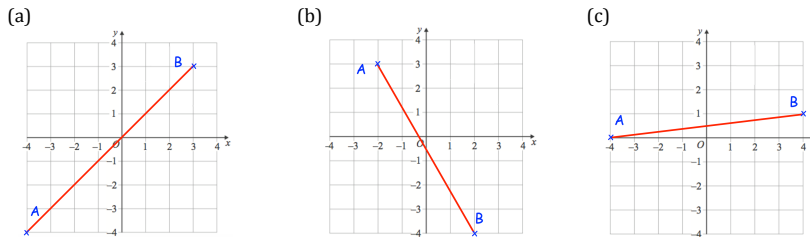

Question 3: Calculate the length of the line joining the point A and B.

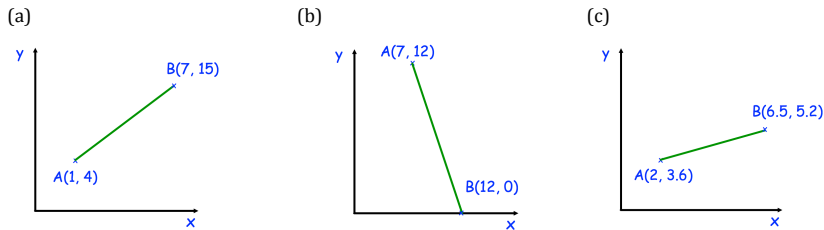

Question 4: Calculate the length of the line joining the points A and B

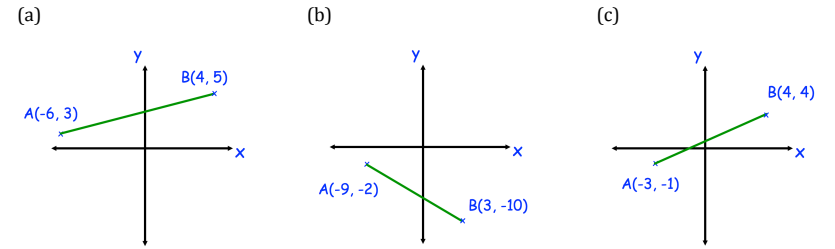

Question 5: Calculate the distance between the following pairs of coordinates

- |                          |                           |                          |
|--------------------------|---------------------------|--------------------------|
| (a) (5, 1) and (9, 6)    | (b) (1, 4) and (10, 10)   | (c) (0, 0) and (6, 8)    |
| (d) (2.5, 3) and (8, 0)  | (e) (-6, 2) and (8, 3)    | (f) (-5, -9) and (-3, 8) |
| (g) (-5, 7) and (-3, -2) | (h) (-9, -9) and (3, -20) | (i) (-4, 0) and (0, -4)  |

## Apply

Question 1: Calculate the perimeter of triangle ABC.

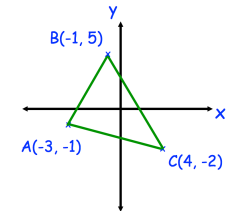

Question 2: The distance between the points (1, 2) and (16, p) is 17. Find the possible values of p.

Question 3: The distance between the points (-3, -4) and (q, 5) is 15. Find the possible values of q.

## Intelligent Practice

Find the length of the line segments between the given points. Give your answers as simplified surds, where appropriate:

1)  $(0, 0)$  and  $(6, 8)$

2)  $(0, 0)$  and  $(-6, 8)$

3)  $(0, 0)$  and  $(6, -8)$

4)  $(0, 0)$  and  $(-6, -8)$

5)  $(1, 1)$  and  $(7, 9)$

6)  $(1, 1)$  and  $(8, 10)$

7)  $(1, 1)$  and  $(-8, 10)$

8)  $(1, 1)$  and  $(8, -10)$

9)  $(1, 1)$  and  $(8, 12)$

10)  $(15, 1)$  and  $(8, 12)$

11)  $(15, 23)$  and  $(8, 12)$

12)  $(1, 1)$  and  $(-16, 20)$

13)  $(1, 1)$  and  $(-17, 19)$

14)  $(-8, 10)$  and  $(-17, 19)$

### EXTENSION

Point A is at  $(1, 2)$ . The distance between Point A and Point B is 10 units.

Find all the possible co-ordinates of Point B.

# Fluency Practice

## Pythagoras' Theorem with Coordinates

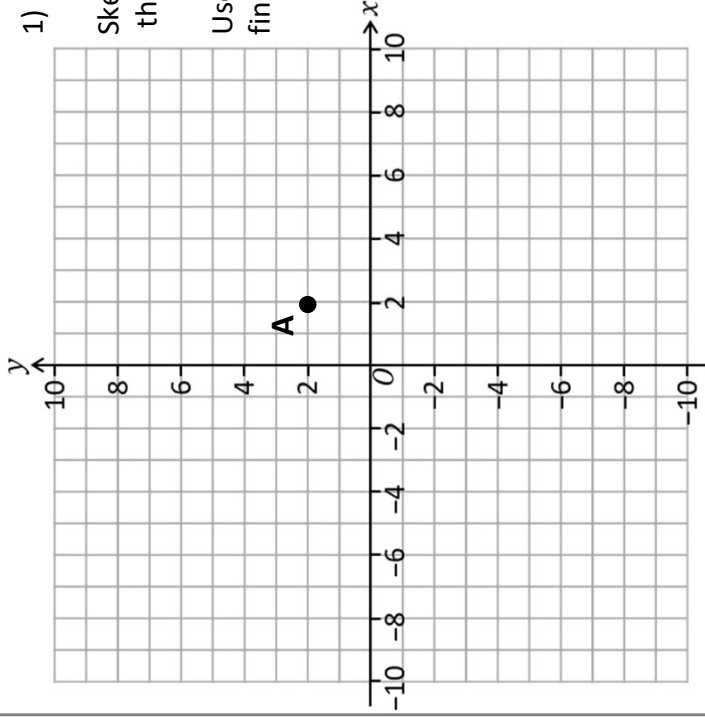

1) Mark point **B** at (8, 6).

Sketch a triangle with line **AB** as the hypotenuse (longest side).

Use Pythagoras' Theorem to find the length of **AB**.

2) **CD** C(2, 8) D(8, 10)

3) **EF** E(-8, 2) F(-6, 9)

4) **GH** G(-2, 1) H(-6, -4)

5) **IJ** I(8, -7) J(3, -2)

6) **KL** K(6, -9) L(-9, -5)

Does it matter if the horizontal or vertical distances are positive or negative?

Find the length of these lines without using a grid.

	Start	End	Horizontal Distance	Vertical Distance	Length
7	(2, 2)	(8, 12)			
8	(8, 3)	(15, 2)			
9	(-5, -6)	(7, -2)			
10	(8, 7)	(-2, -1)			
11	(-11, -2)	(-3, -18)			

12) The length of line **MN** is 13 grid units.

**M**(-6, 3) **N**(-1,  $y$ )

Find a possible  $y$  co-ordinate of point **N**.

13) The length of line **OP** is 9 grid units.

**O**( $x$ , -4) **P**(1, -10)

Find a possible  $x$  co-ordinate of point **O**.

# Extension

equilateral triangle or not?

(1)

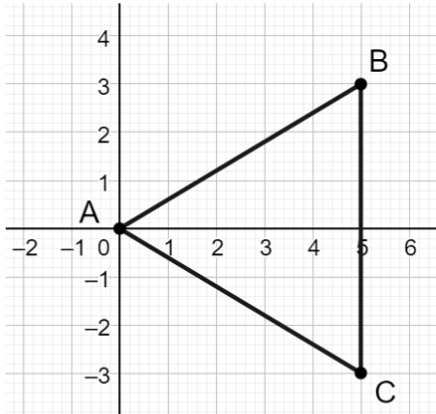

(2)

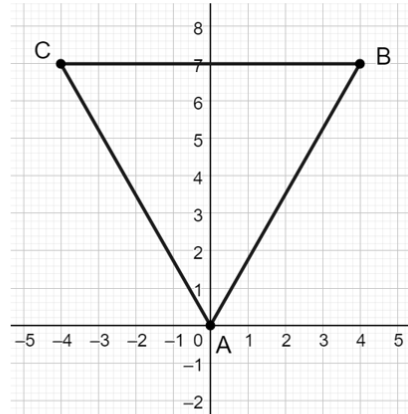

(3)

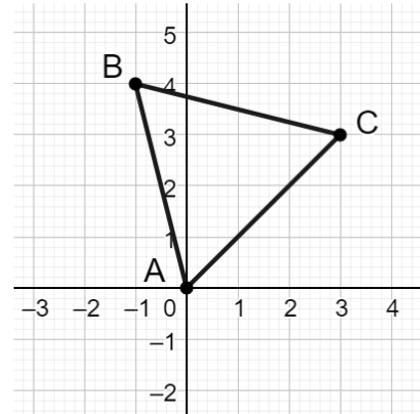

(4)

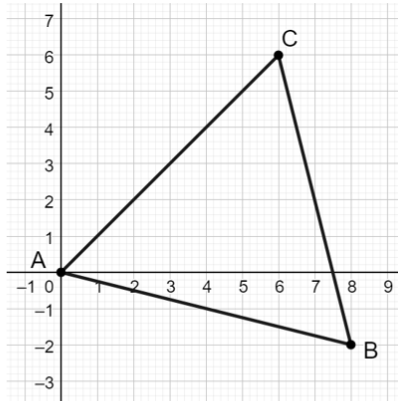

(5)

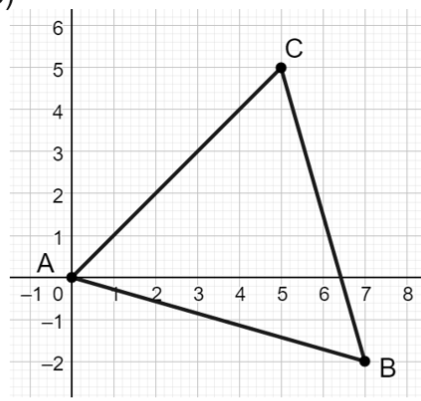

(6)

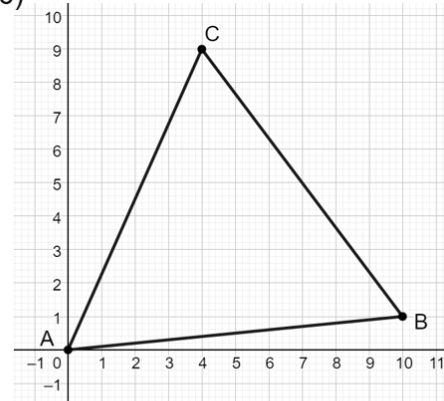

# Fluency Practice

Question 1 1234 ↻

$ABC$  is an isosceles triangle where  $AB = BC$ .

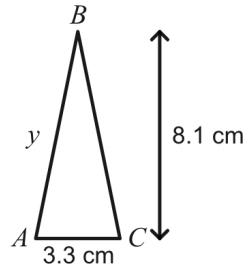

Work out the length marked  $y$  on the diagram.  
Give your answer correct to 1 decimal place.

Question 4 1234 ↻

$DEF$  is an isosceles triangle where  $DE = EF$ .

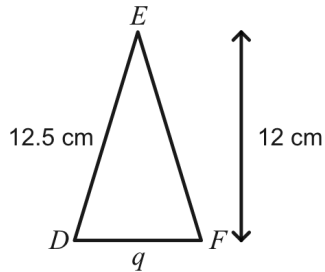

Find the length marked  $q$  on the diagram.  
Give your answer correct to 1 decimal place.

Question 2 1234 ↻

$PQR$  is an isosceles triangle where  $PQ = QR$ .

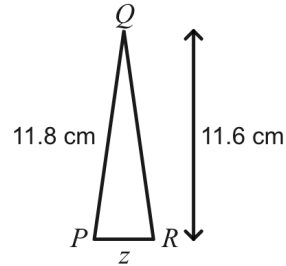

Find the length marked  $z$  on the diagram.  
Give your answer correct to 1 decimal place.

Question 5 1234 ↻

$DEF$  is an isosceles triangle where  $DE = EF$ .

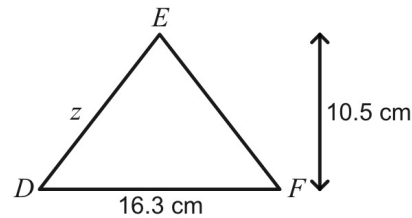

Work out the length marked  $z$  on the diagram.  
Give your answer correct to 1 decimal place.

Question 3 1234 ↻

$DEF$  is an isosceles triangle where  $DE = EF$ .

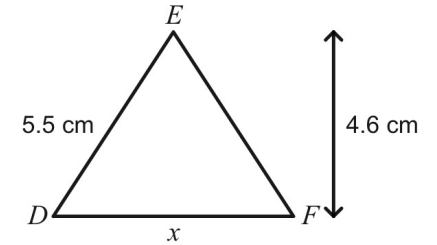

Calculate the length marked  $x$  on the diagram.  
Give your answer correct to 1 decimal place.



# Fluency Practice

Question 1 1 2 3 4 

Work out the value of  $x$ .

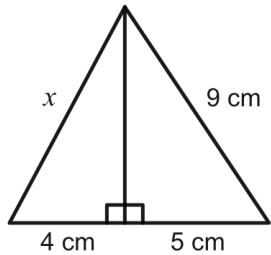

Give your answer correct to 1 decimal place.

Question 4 1 2 3 4 

Work out the value of  $x$ .

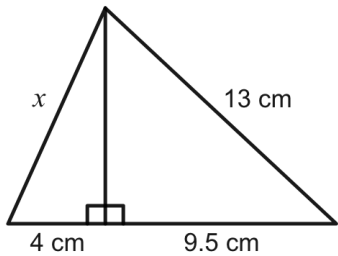

Give your answer correct to 1 decimal place.

Question 2 1 2 3 4 

Work out the value of  $x$ .

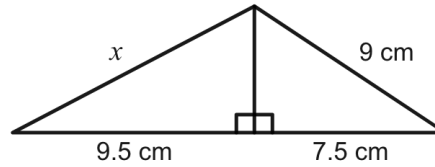

Give your answer correct to 1 decimal place.

Question 5 1 2 3 4 

Work out the value of  $x$ .

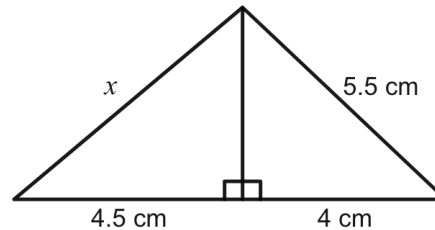

Give your answer correct to 1 decimal place.

Question 3 1 2 3 4 

Work out the value of  $x$ .

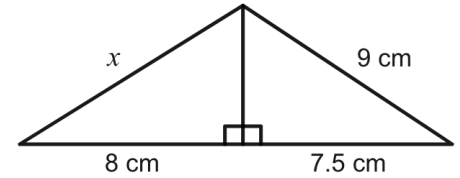

Give your answer correct to 1 decimal place.

# Fluency Practice

Question 1 1 2 3 4 

Determine the value of  $y$ .

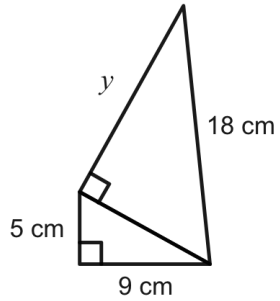

Give your answer correct to 1 decimal place.

Question 2 1 2 3 4 

Determine the value of  $z$ .

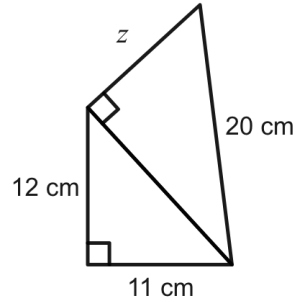

Give your answer correct to 1 decimal place.

Question 3 1 2 3 4 

Work out the value of  $x$ .

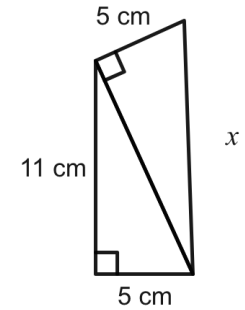

Give your answer correct to 1 decimal place.

Question 4 1 2 3 4 

Find the value of  $z$ .

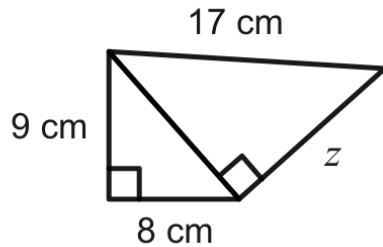

Give your answer correct to 1 decimal place.

Question 5 1 2 3 4 

Work out the value of  $x$ .

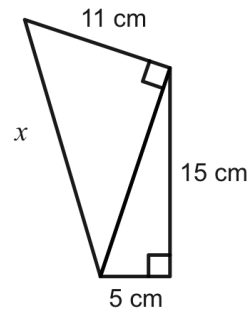

Give your answer correct to 1 decimal place.

# Fluency Practice

Find each of these lengths, rounding to 1 decimal place when necessary.

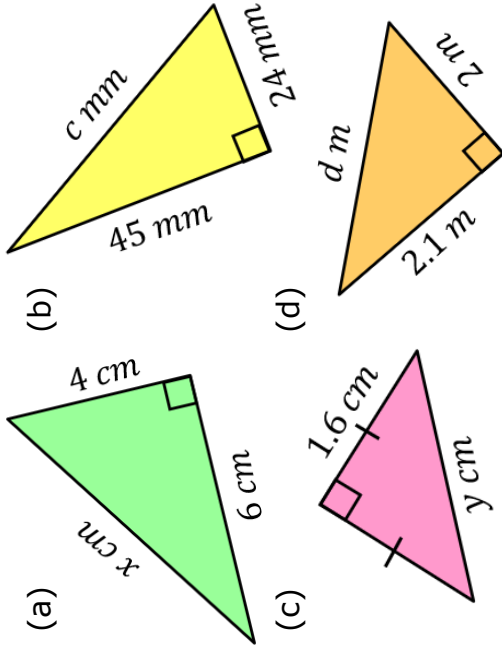

Find each of these lengths, leaving your answers in surd form.

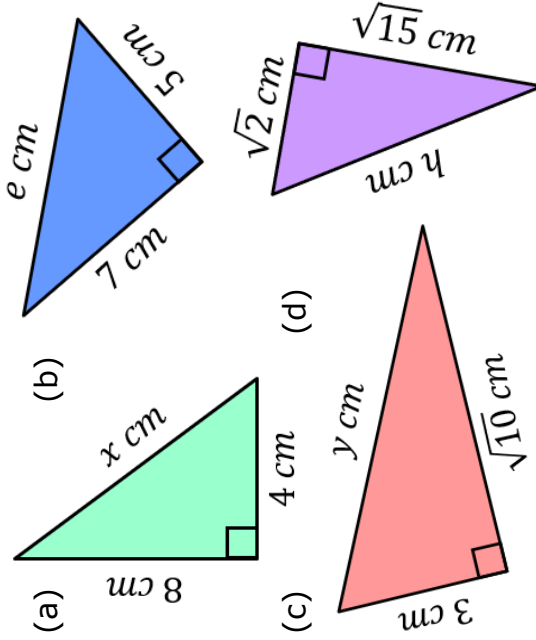

Find the missing lengths, rounding your answers to 3 significant figures.

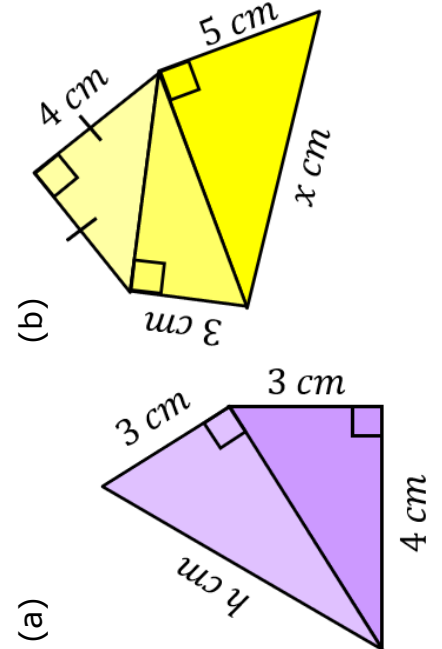

# Fluency Practice

Find each of these lengths, rounding to 1 decimal place when necessary.

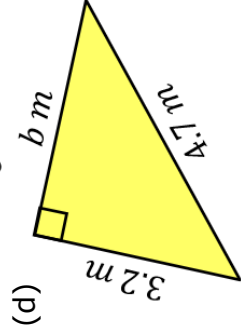
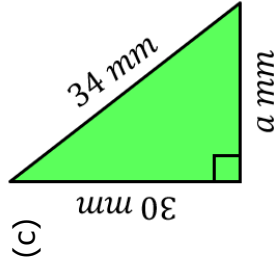
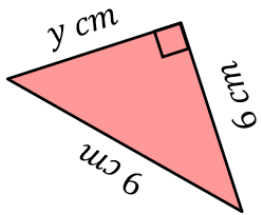
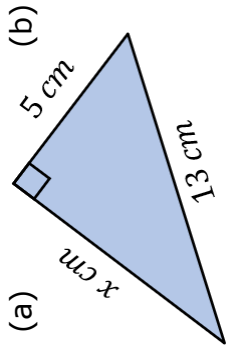

Find each of these lengths, leaving your answer in surd form.

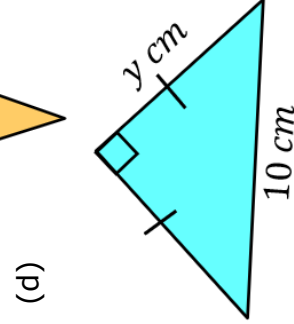
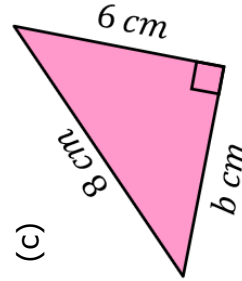
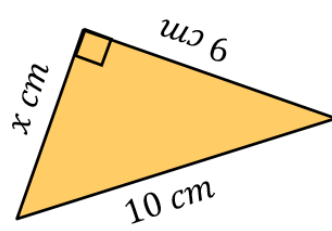
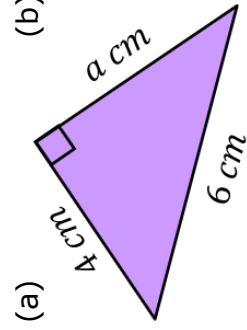

Find the missing lengths, rounding your answers to 3 significant figures.

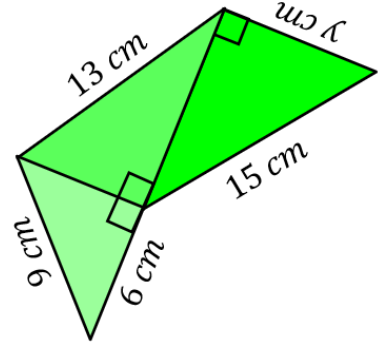
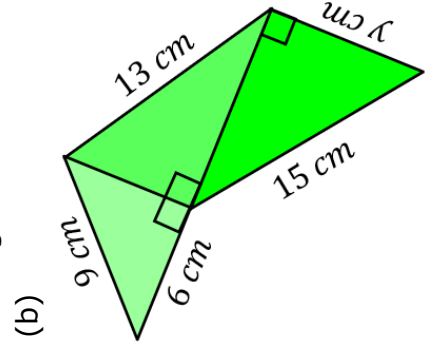
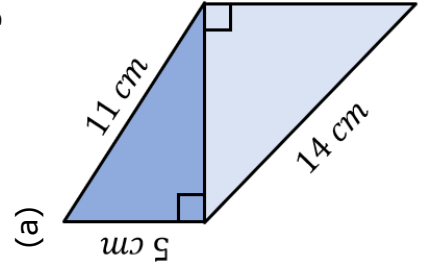

# Fluency Practice

Find the missing lengths.

(a)

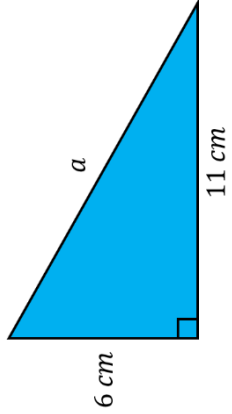

(b)

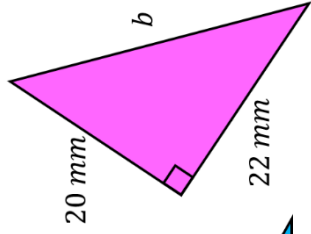

Find the missing lengths.

(a)

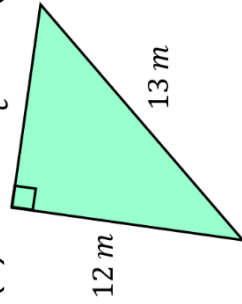

(b)

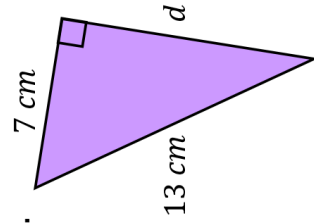

Find the missing lengths.

(a)

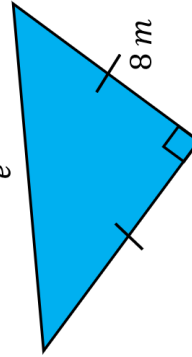

(b)

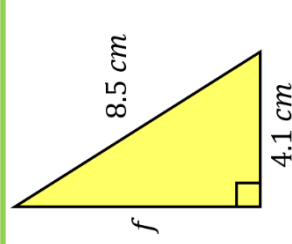

(c)

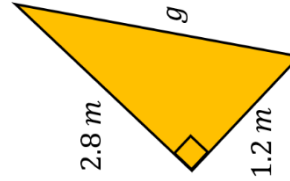

(d)

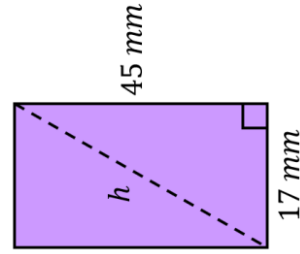

Find the missing lengths.

(a)

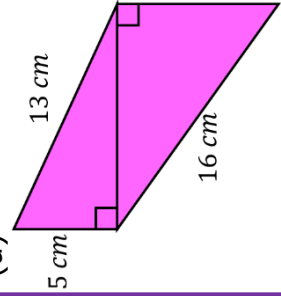

(b)

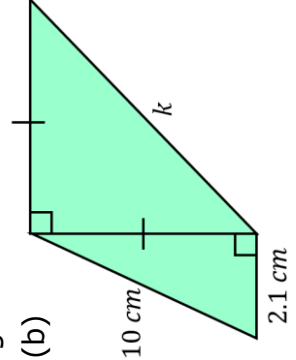

## Fluency Practice

**Question 1** 1 2 3 4 ↺

Find the value of  $x$ .

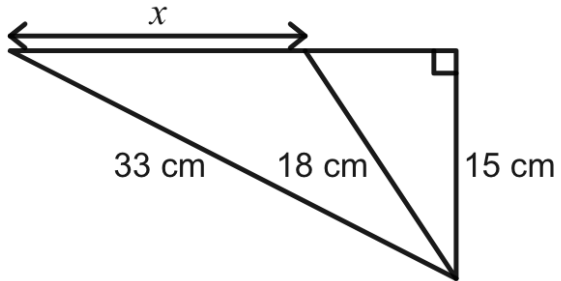

Give your answer correct to 1 decimal place.

**Question 2** 1 2 3 4 ↺

Find the value of  $y$ .

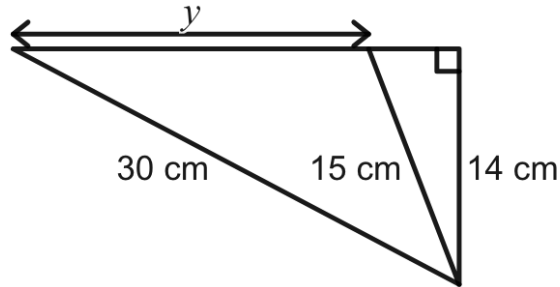

Give your answer correct to 1 decimal place.

**Question 3** 1 2 3 4 ↺

Find the value of  $x$ .

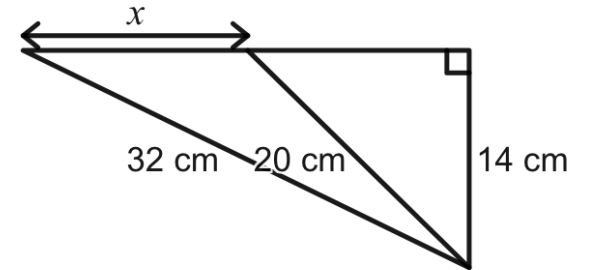

Give your answer correct to 1 decimal place.

**Question 4** 1 2 3 4 ↺

Find the value of  $y$ .

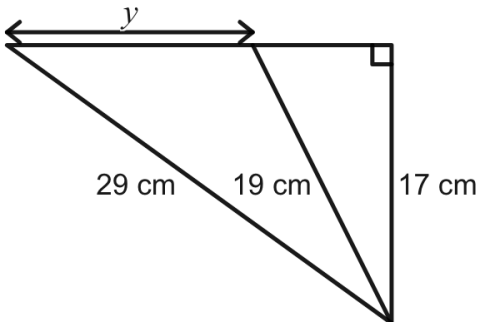

Give your answer correct to 1 decimal place.

**Question 5** 1 2 3 4 ↺

Find the value of  $x$ .

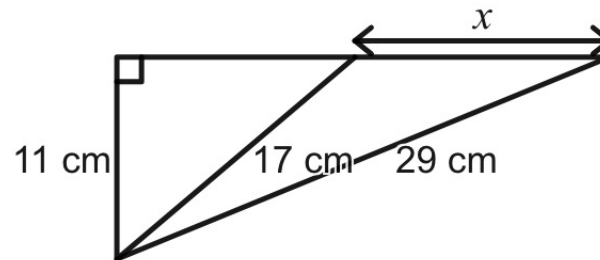

Give your answer correct to 1 decimal place.

# Intelligent Practice

Find the value of  $x$  in each instance to 2dp. Predict whether you think each answer will be higher or lower than the one before it.

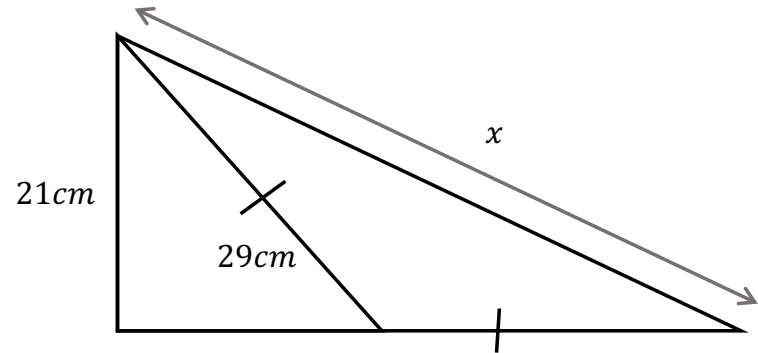
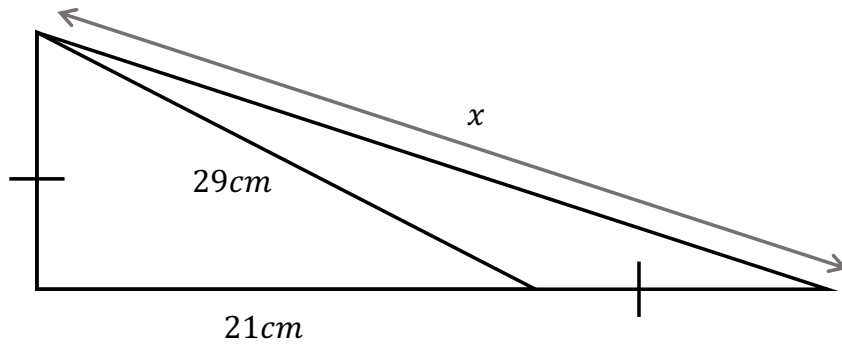
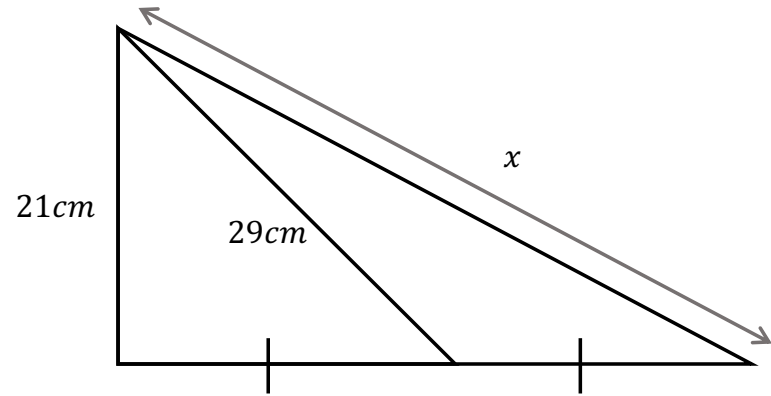
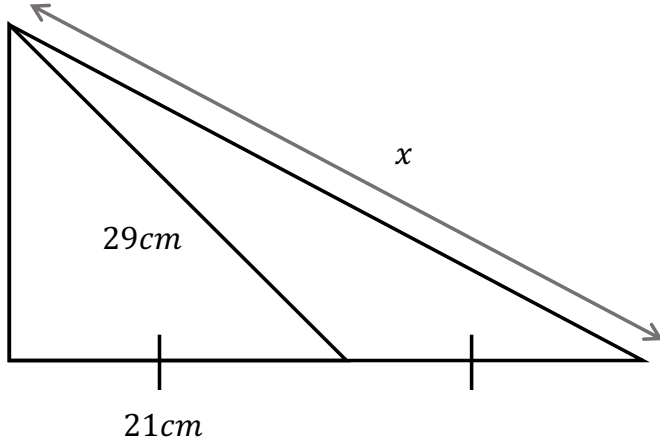

# Intelligent Practice

Find the value of  $x$  in each instance to 2dp. Predict whether you think each answer will be higher or lower than the one before it.

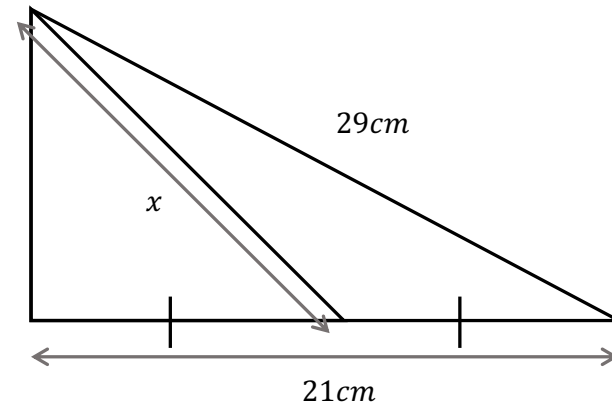
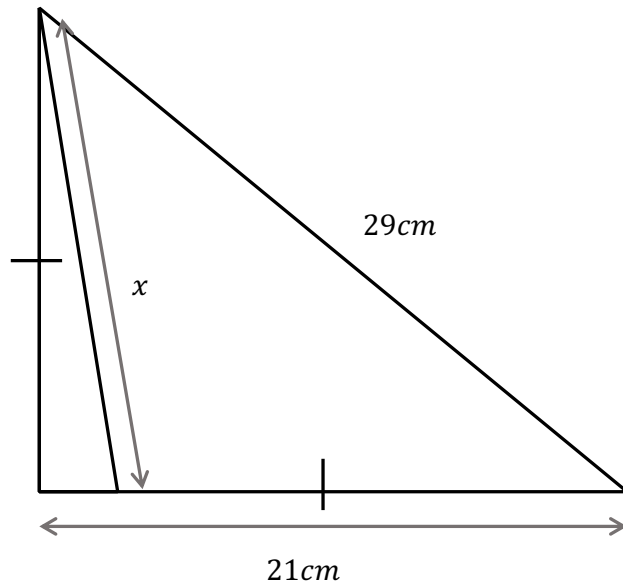
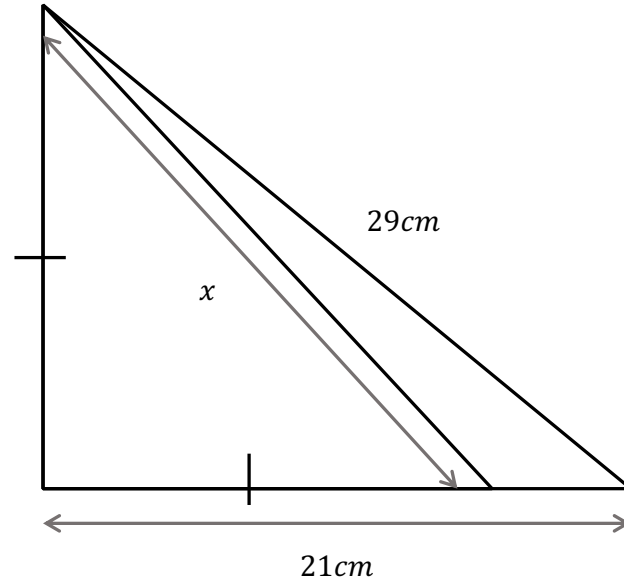
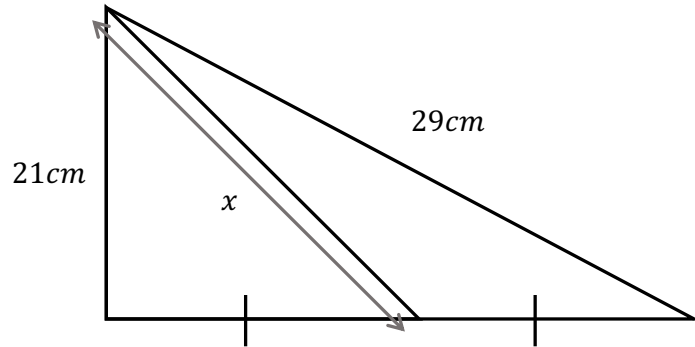



# Fluency Practice

## Multi-Step Pythagoras' Theorem

**(a)**

Find  $x$  and  $y$ , rounding to 1 decimal place where necessary.

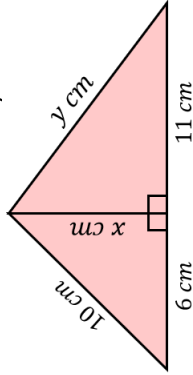

**(b)**

Find  $x$  and  $y$ , rounding to 1 decimal place where necessary.

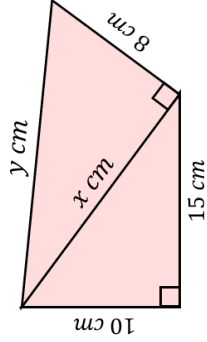

**(c)**

Find  $x$ , to 1 decimal place.

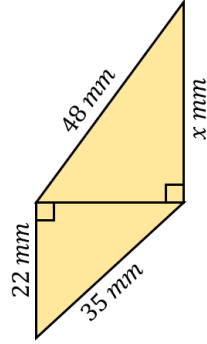

**(d)**

Find  $x$ , to 1 decimal place.

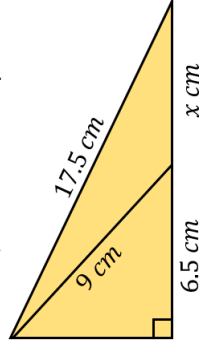

**(e)**

Find  $x$ , to 1 decimal place.

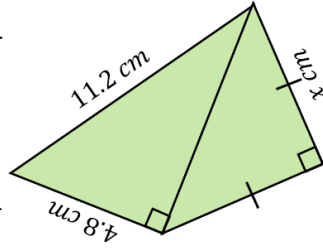

**(f)**

Find  $x$ , to 1 decimal place.

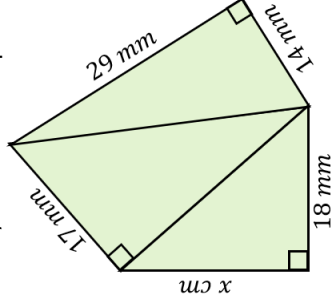

# Fluency Practice

Using Pythagoras' Theorem

Find each missing length.

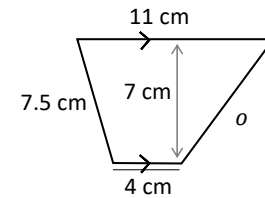
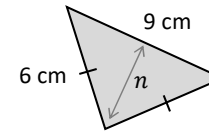
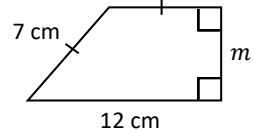
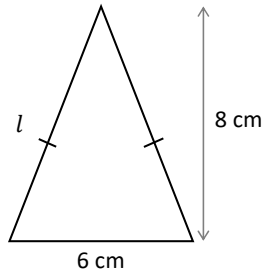
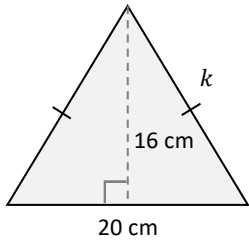
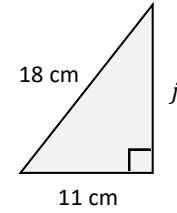
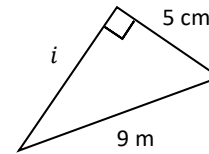
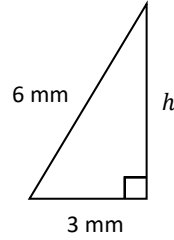
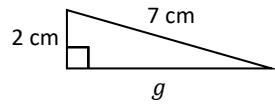
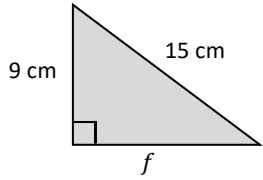
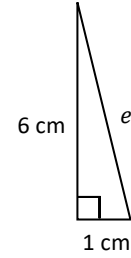
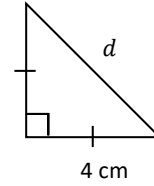
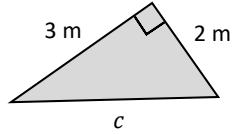
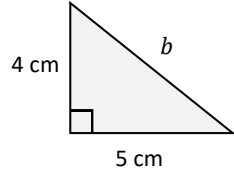
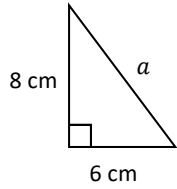

14 Answers	5.7	12	5.2	18.9	6.1	4.0	3.6
	14.2	6.4	4.9	10	8.5	7.5	6.7

# Fluency Practice

Keep it in the Calculator!

What **method** can you use to find the value of each letter? Lengths are cm.

NOT DRAWN ACCURATELY

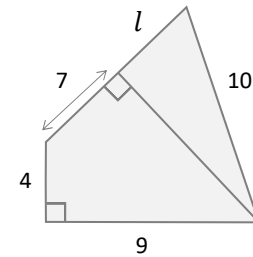
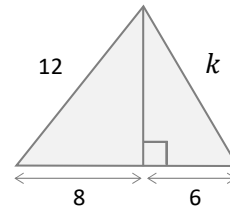
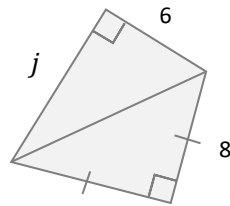
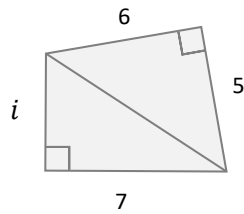
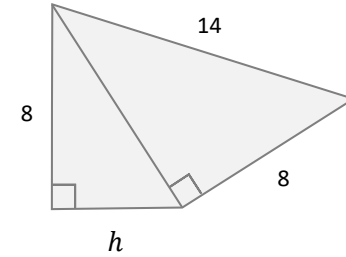
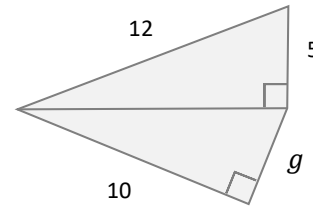
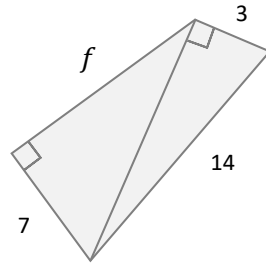
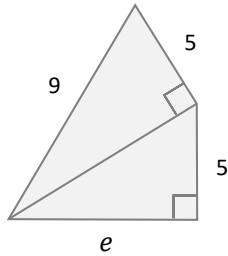
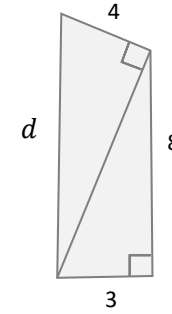
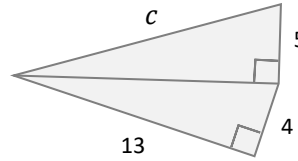
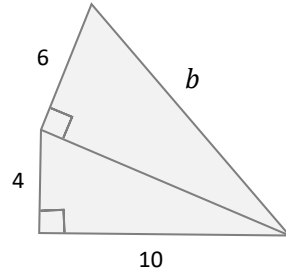
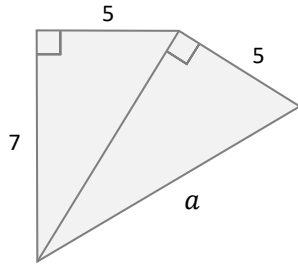

10 Answers	5.6	4.4	9.9	8.2	14.5
	12.3	9.4	9.6	11.7	3.5

# Fluency Practice

Keep it in the Calculator!

What **method** can you use to find the value of each letter? Lengths are cm.

NOT DRAWN ACCURATELY

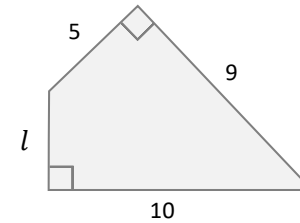
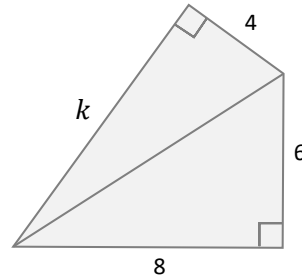
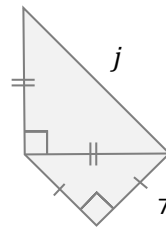
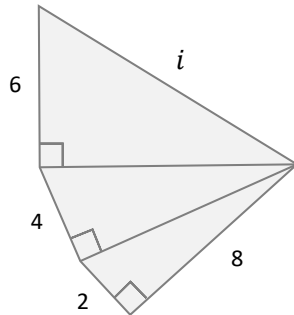
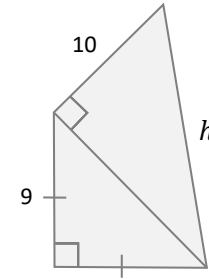
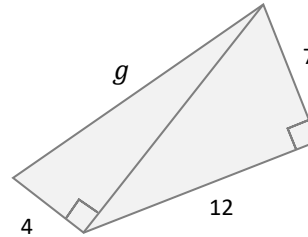
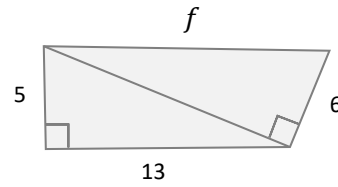
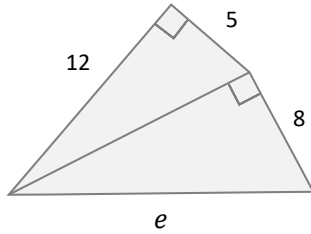
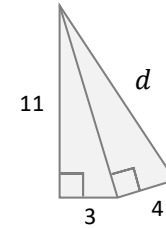
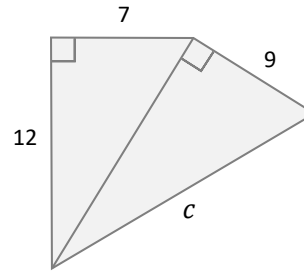
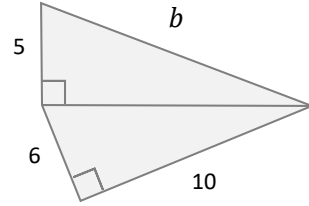
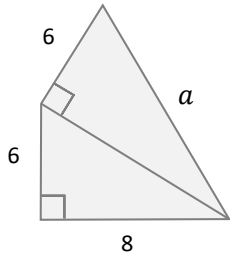

10 Answers	12.7	16.2	15.2	15.3	16.6
	11.0	12.1	14	11.7	14.5

# Fluency Practice

**A1** Find length  $BC$

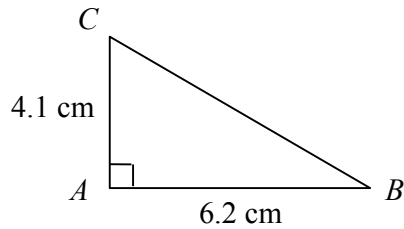

**A2** Find length  $AC$

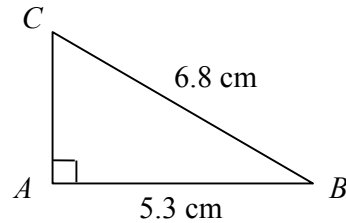

**A3** Find length  $BC$

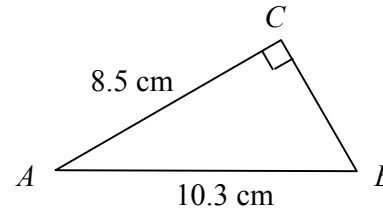

**A4** Find length  $AB$

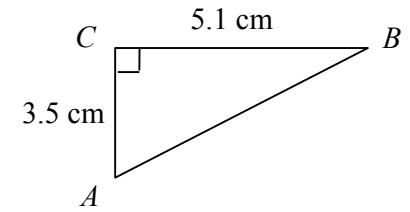

**B1** Find length  $BC$

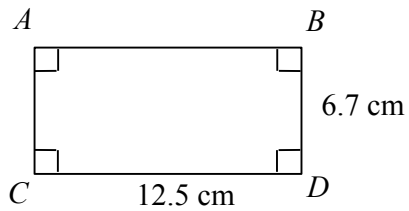

**B2** Find length  $AD$

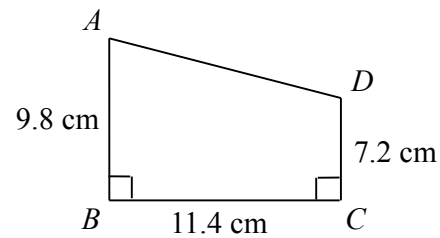

**B3** Find the area

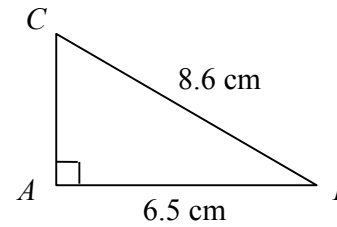

**B4** Find the area

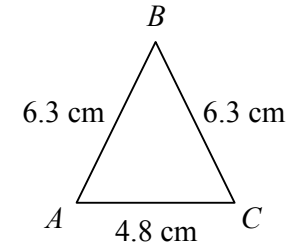

**C1** Find length  $CD$

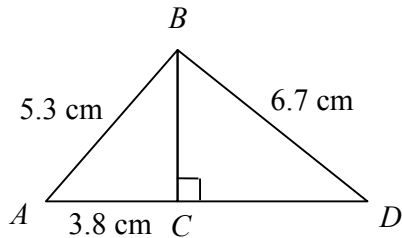

**C2** Find length  $AC$

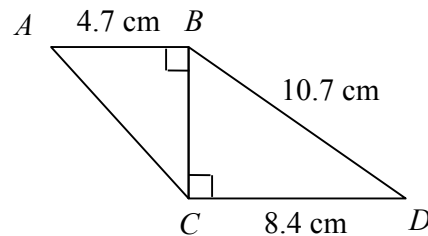

**C3** Find length  $BC$

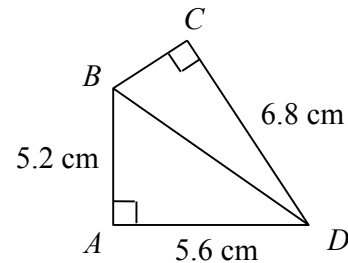

**C4** Find length  $CD$

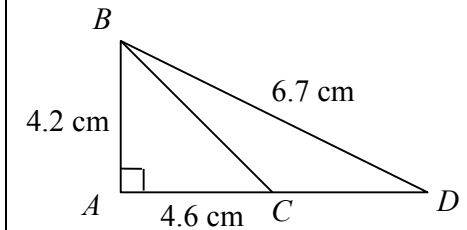

# Purposeful Practice

## PYTHAGORAS PILE UP

In each case, find the hypotenuse of the top triangle, correct to 1 decimal place.

All the triangles are right-angled. Not to scale. No rounding until the end!

A.

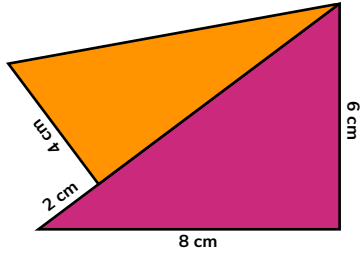

B.

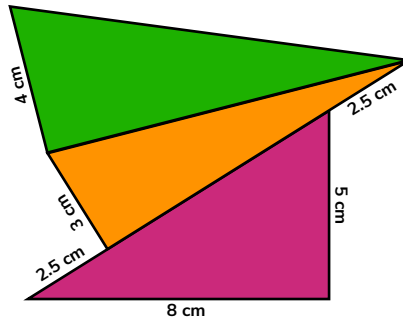

C.

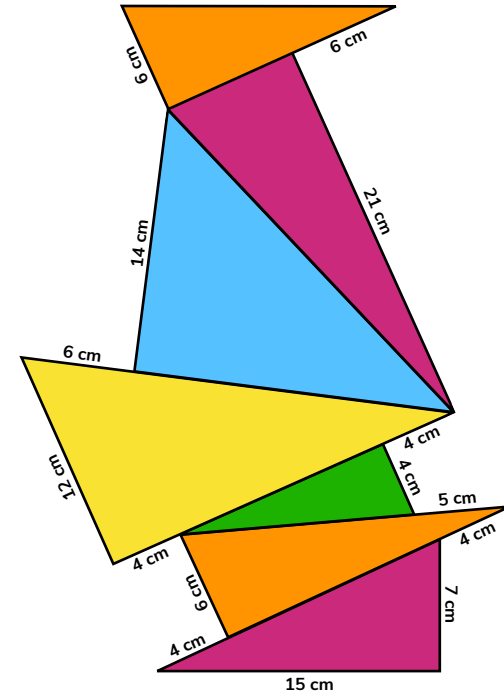

# Purposeful Practice

## Pythagoras Pile-Up!

Can you find  $x$ ?

Start at the bottom and label each length you can find.

Try to keep as much accuracy as possible!

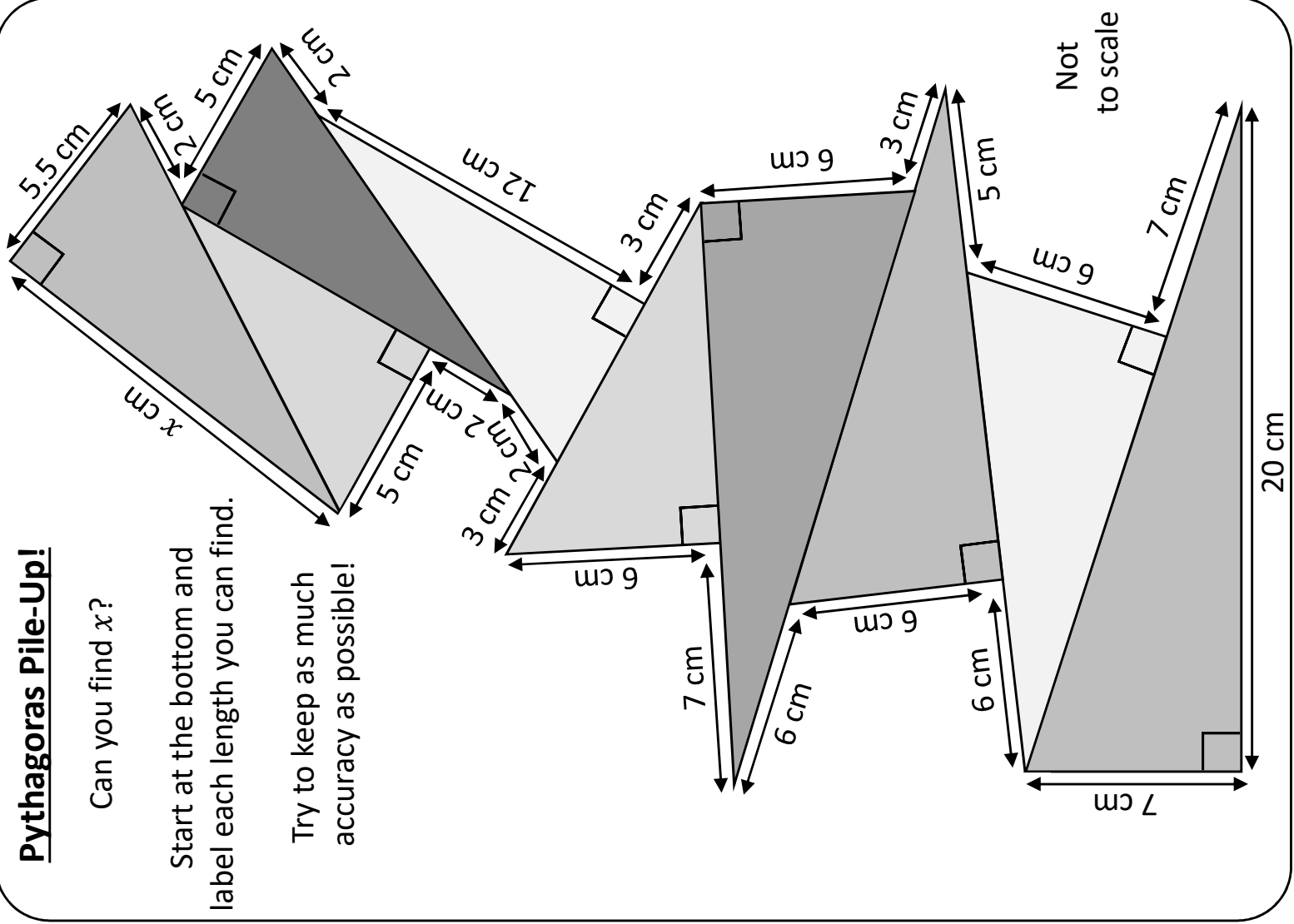

# Purposeful Practice

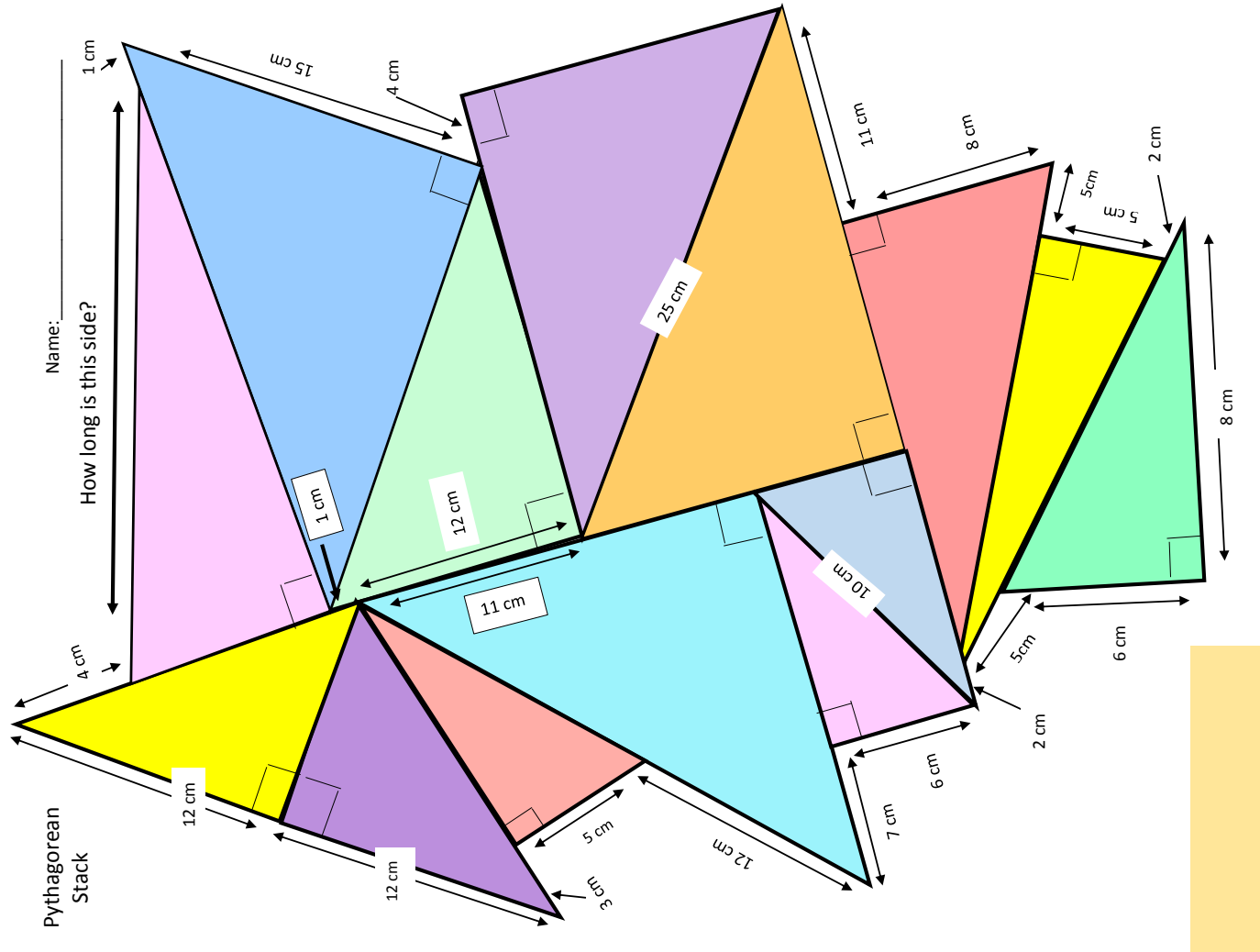



# Fluency Practice

## Pythag. Shell

All the triangles making up the shell are right-angled and they all have the same height.

Find the value of  $x$ .

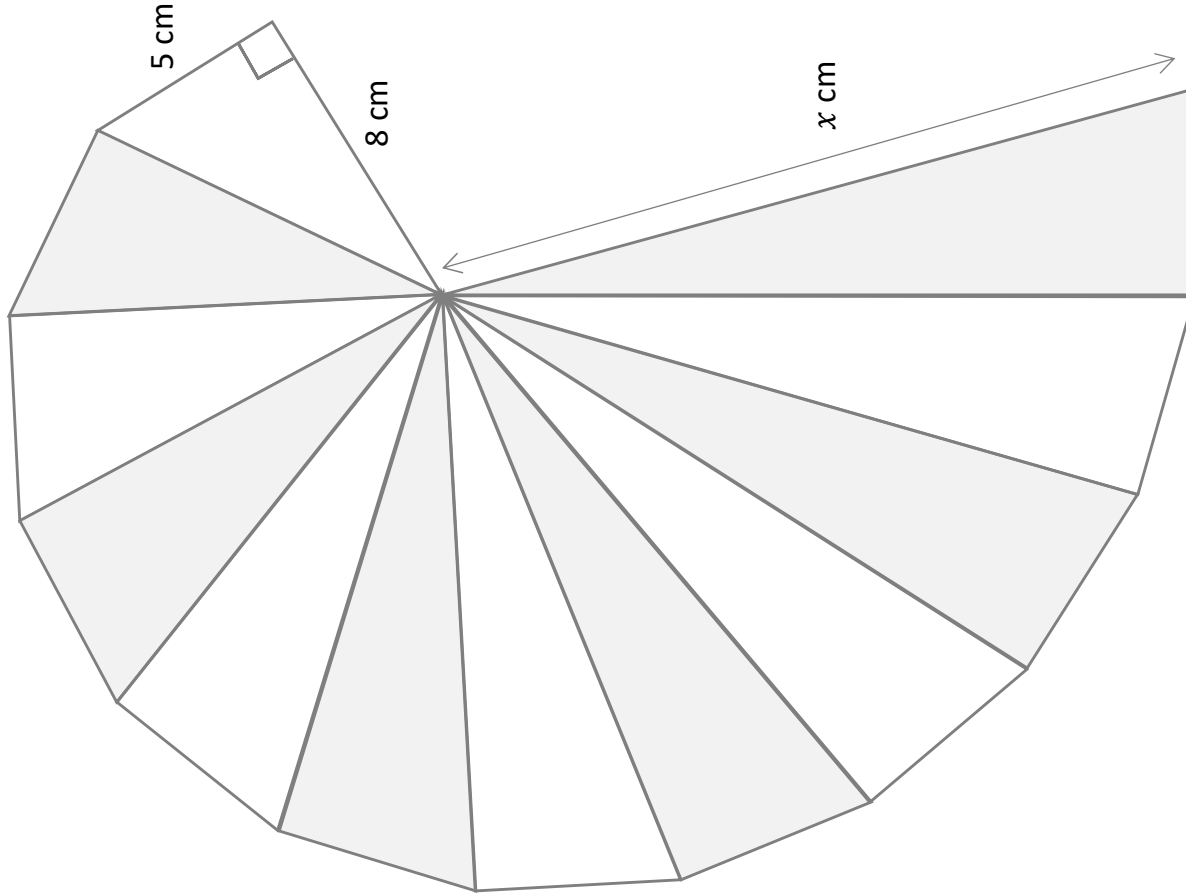

# Fluency Practice

## Pythagoras' Theorem Worded Problems

**(a)**

A ladder which is 7.5 m long, leans against a wall. The foot of the ladder is 1.8 m from the foot of the wall. How far up the wall does the ladder reach to 1 decimal place?

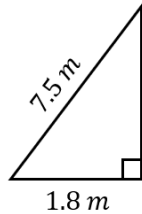

**(b)**

A ship sails 150 km west, then turns and sails 130 km south. How far from its original position is the ship now, to the nearest km?

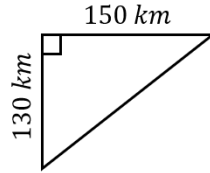

**(c)**

A football pitch is 90 m by 50 m. Find the length of the diagonal of the pitch to 1 decimal place.

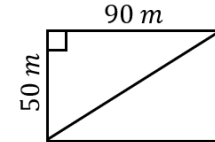

**(d)**

A snail starts at point A and travels 75 cm east and then 60 cm north to point B. Find the direct distance from A to B.

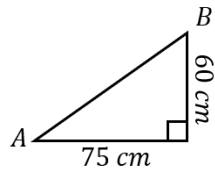

**(e)**

A ladder leans against a wall. The foot of the ladder is 2.3 m from the foot of the wall, and the ladder reaches 9 m up the wall. How long is the ladder, to 1 decimal place?

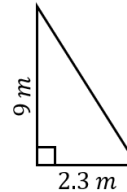

**(f)**

A farmer has a field in the shape of a trapezium, as shown. He wants to put a fence all the way around the field. How long will the fence need to be, to 1 decimal place?

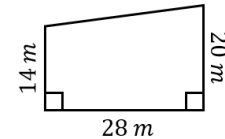

**(g)**

A netball pitch is 15 metres wide and 30 metres long. Find the length of the diagonal to 1 decimal place.

**(h)**

A bird flies from its nest 2 km due north, then 3.5 km due east. Find the distance of the bird from its nest after its flight.

**(i)**

A ladder of length 8.2 m leans against a wall. The ladder reaches 6.9 m up the wall. How far is the foot of the ladder from the foot of the wall?

## Fluency Practice

(a) A model football pitch is 2m long and 0.5m wide. How long is the diagonal?

(b) A 12m long ladder leans against a wall. The foot of the ladder is 2.5m from the foot of the wall. How far up the wall does the ladder reach?

(c) A triangle has sides 7cm, 24 cm and 26 cm. Is the triangle right-angled?

(d) Find the length of the line that joins the coordinate points (13, 6) and (1, 1).

(e) A boat sails 40km east then turns and sails 50km south. How far is the boat from its original position?

(f) A ladder, 15m long, leans against a wall. If it needs to reach 12 m up the wall, how far from the foot of the wall must the ladder be placed?

(g) A piece of land is in the shape of an isosceles triangle with sides 6.5m, 6.5m and 7.4m. Find the area of the piece of land.

(h) A 10m mast on a boat is supported by a wire called a stay. The stay is 11m long. How far from the base of the mast does the stay reach?

(i) A rectangle is 4cm long. The length of the diagonal is 5cm. What is the area of the rectangle?

(j) Calculate the area of an equilateral triangle with side length 10mm.

(k) Calculate the area of a regular hexagon with side length 8 cm.

# Fluency Practice

## Practical Pythagoras Problems

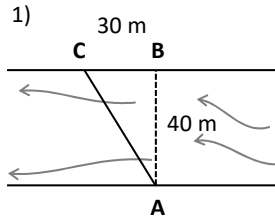

Mak tries to swim across this river from **A** to **B**.  
The river is 40 m wide.  
The current pushes him 30 m downstream to **C**.  
How far did Mak actually travel in total?

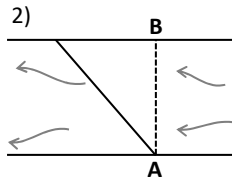

Emily tries to swim across this river from **A** to **B**.  
The river is 37 m wide & she actually travels 72 m.  
How far downstream from **B** did Emily arrive?

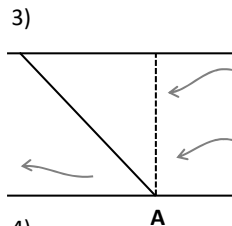

Max tries to swim directly across a river from **A**.  
In total he swims 108 m.  
The current pushes him 84 m away from his target.  
How wide is the river?

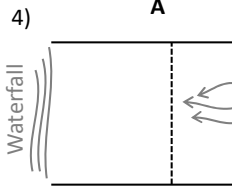

Pai tries to swim directly across a 32 m wide river, 238 m before a waterfall.  
In total she travels 245 m.  
Does Pai make it across before the waterfall?

5)  
Tran swims at 1.2 m/s perpendicular to a river's current.  
The river's current has a speed of 0.8 metres per second.  
What is Tran's total speed?

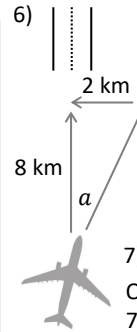

A runway is 8 km directly North from a plane coming to land.  
The wind is coming directly from the East.  
If the pilot does not fly into the wind, the wind will push the plane 2 km West & off course.  
How far must the plane actually fly to reach the runway?



7)  
On approach, a crosswind will push a plane 7 km left of the runway. The plane must fly 45 km to reach the runway. How far is the runway from the plane?

8)

A plane's engine propels it forward at 300 m/s.  
A perpendicular crosswind pushes the plane directly sideways at 50 m/s.  
How far does the plane actually travel in one second?

9)

A plane's engine propels it forward at 280 m/s.  
In one second the plane actually travels 300 metres (its *groundspeed*).  
What is the speed of the perpendicular crosswind?

10)

A pilot wants to land with a groundspeed of 352 m/s.  
The crosswind is 22 m/s.  
At what speed must the pilot fly into the crosswind?

## Fluency Practice

### WORDED: PYTHAG.

- 1) Denise uses a ladder to install a light on a wall. The ladder needs to reach a height of 5 metres. For safety, the base of the ladder must be 2 metres from the base of the wall. What minimum length must the ladder be?
- 2) Kelly is jumping from a 12 metre tall sea-cliff. Rocks extend for 4 metres perpendicular to the base of the cliff.  
To land safely in the water, how far must Kelly travel in total?
- 3) James travels down a straight water-slide. He loses 17 metres in height over 86 metres. How far horizontally did James travel?
- 4) A zip-line is 250 metres long. It travels a horizontal distance of 140 metres.  
How far does the zip-line drop from start to finish?
- 5) Sandy climbs a mountain in the Alps. She walks 24 km but only travels 23.5 km South. Approximately how many metres in height did Sandy gain by climbing the mountain?
- 6) The Metrix building is 225 metres tall. 50 metres away is the Kerber building which stands at 150 metres tall.  
How far is it between the tops of these buildings?
- 7) The apex of a roof is made by leaning 6-metre pieces of wood together. The base of the roof is 4 metres wide. How tall is the roof?
- 8) An equilateral triangle has a side length of 8 centimetres.  
What is the area of the triangle?
- 9) Danny travels North & Michele travels East, both at the same speed. After 3 hours they are 12 kilometres apart. How far did Danny travel?

# Extension

diagrams are not drawn accurately  
give your answers to 2 decimal places

KS3 SAT questions (i)

## missing sides

(a) calculate the length of the longest side ( $AB$ ) of a right-angled triangle  $ABC$  with shorter sides  $BC = 2\text{cm}$  and  $AC = 5\text{cm}$

(b) calculate the length of the side of a right-angled triangle  $DEF$  with a hypotenuse  $EF = 15\text{cm}$  and another side  $DE = 14\text{cm}$

## ramp

a ramp that is  $10\text{m}$  long must not have a height greater than  $0.83\text{m}$   
here is the side view for a ramp

is this ramp too high?  
please show calculations to explain your answer

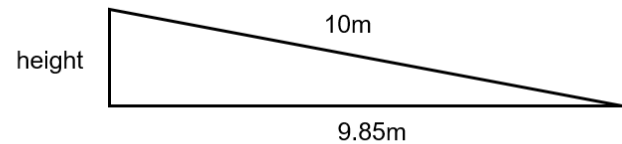

## boat

a boat sails from the harbour to a buoy which is  $6\text{km}$  to the east and  $4\text{km}$  to the north of the harbour  
calculate the shortest distance between the buoy and the harbour

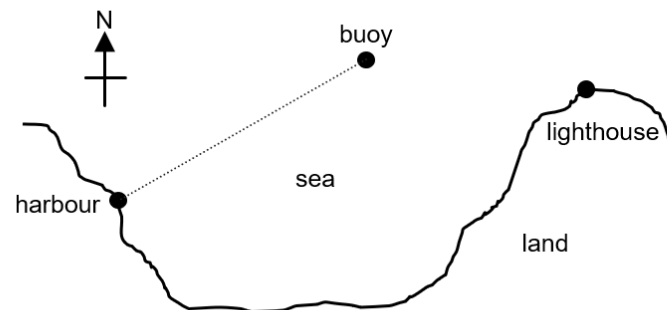

# Extension

KS3 SAT questions (ii)

## two triangles

$ABC$  and  $ACD$  are both right-angled triangles  
calculate the length of  $AD$

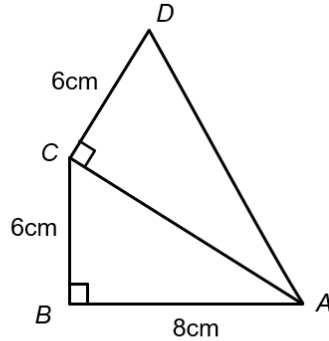

## trapezium

work out the size of length  $k$

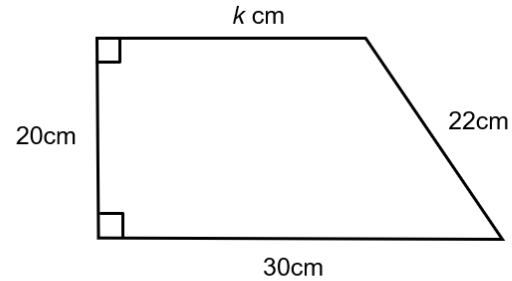

## perimeter

two right-angled triangles are joined together to  
make a larger triangle  $ADC$

- (a) show that the perimeter of triangle  $ADC$  is 78 cm
- (b) show that triangle  $ADC$  is right-angled

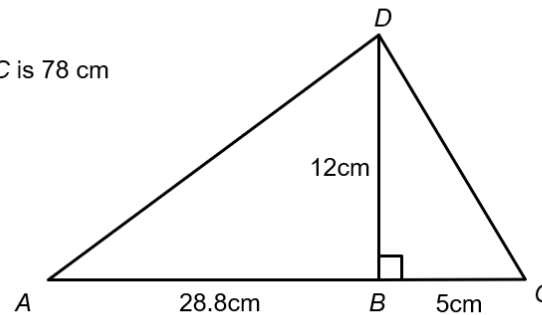

diagrams are not  
drawn accurately

give your answers to  
2 decimal places

# Fluency Practice

Find the area and perimeter of each triangle

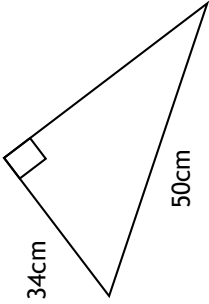
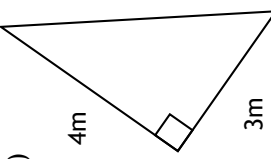
a)  

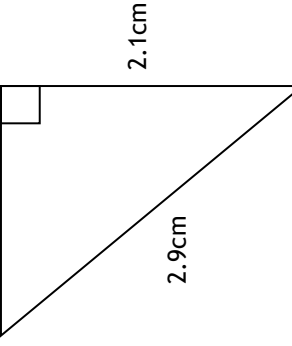
b) 

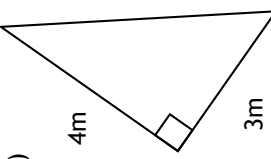
c) 

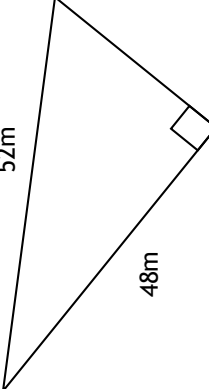
d) 

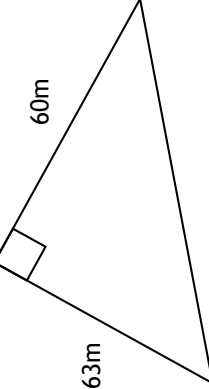
e) 

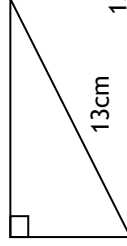
f) 

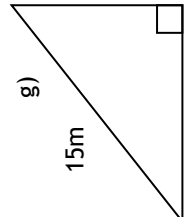
g) 

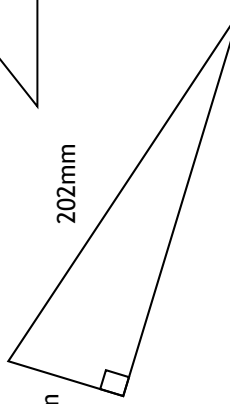
h) 

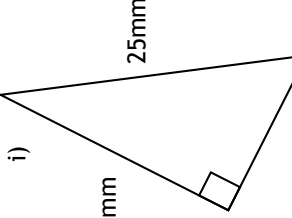
i) 

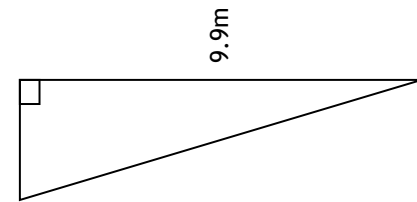
j) 

Which triangles above are similar? Write the pairs.

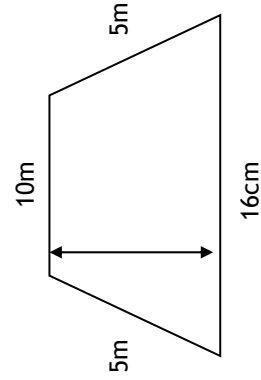

Find the height of the trapezium



# Fluency Practice

Find the perimeter of each shape to 1dp - all arcs are either semicircles, quarter circles or three-quarter circles

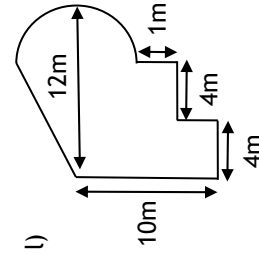
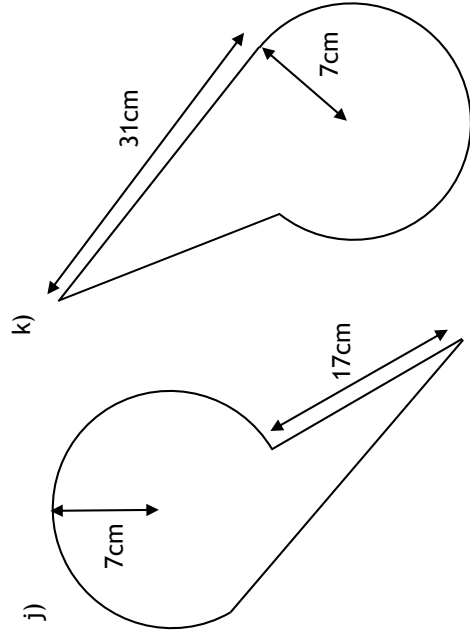
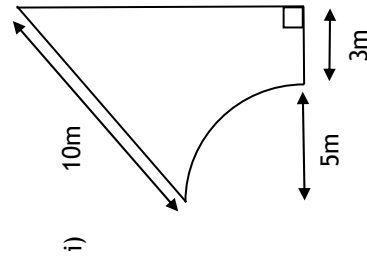
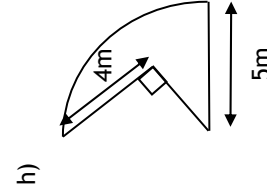
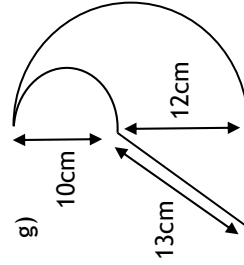
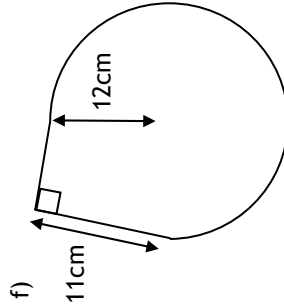
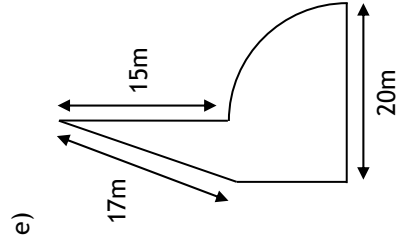
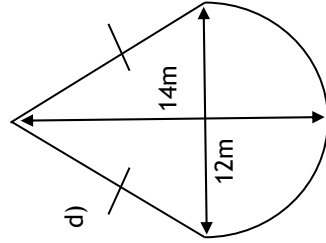
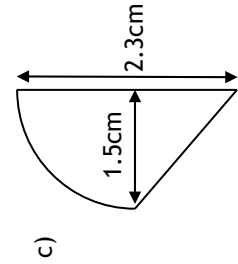
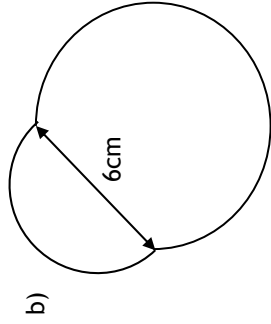
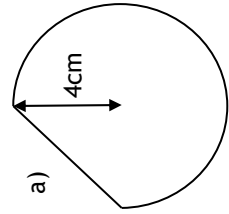

# Fluency Practice

Find the perimeter of each shape to 1dp - all arcs are either semicircles, quarter circles or three-quarter circles

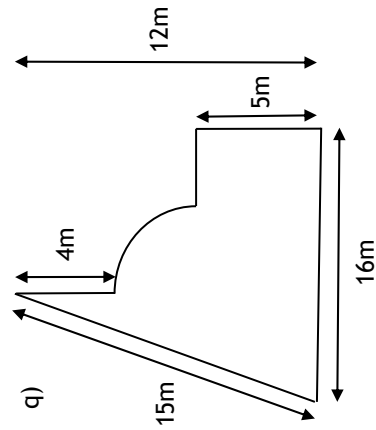
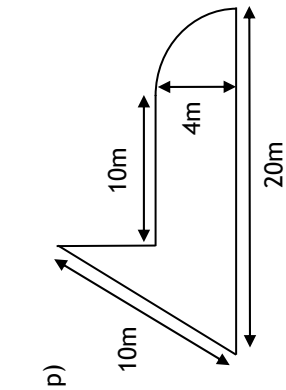
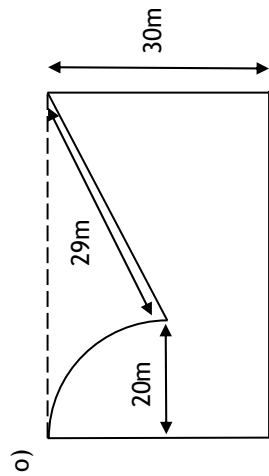
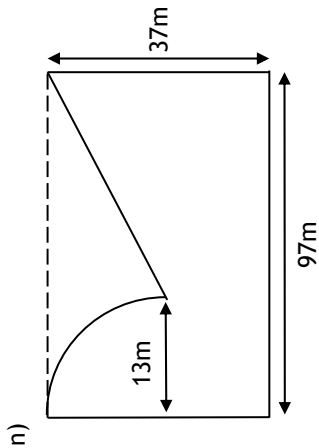
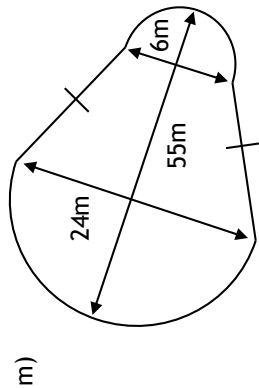

r) *The shape below is made of 10 congruent triangles surrounding a rectangle*

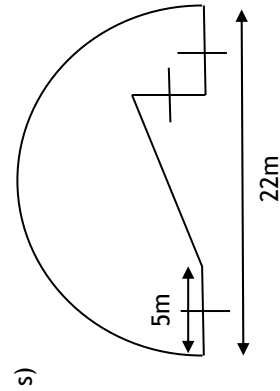
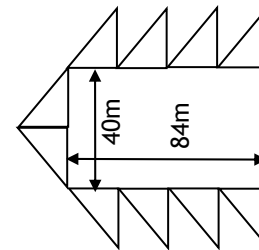

## 2 Properties of 3D Shapes

# Fluency Practice

Question 1: For each 3D shape below, write down how many edges, faces and vertices it has.

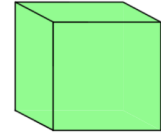

(a)

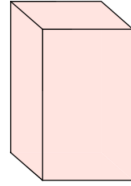

(b)

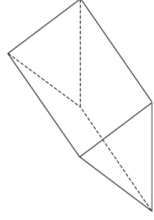

(c)

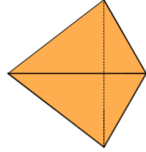

(d)

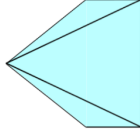

(e)

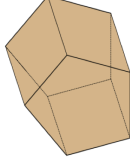

(f)

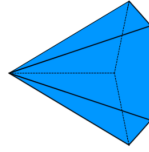

(g)

Question 1: Can you spot any mistakes in the question below?

	Faces	Edges	Vertices
Cube	12	6	8
Square-based Pyramid	5	5	5
Triangular Prism	9	9	6

# Fluency Practice

## example

A square-based pyramid has:

**5 vertices**

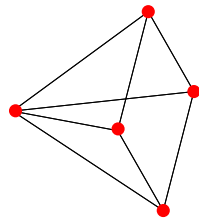

**8 edges**

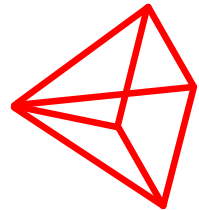

**5 faces**

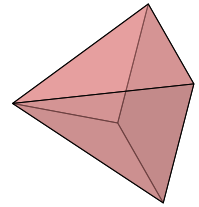

## exercise

1. State the number of faces, edges and vertices of each shape:

a) Cuboid

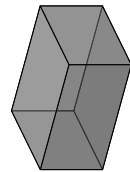

b) Triangular prism

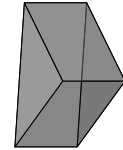

c) Cone

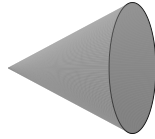

d) Trapezoidal prism

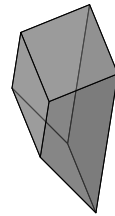

e) Cylinder

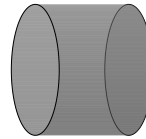

f) Cube

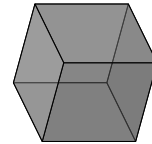

2. a) State the number of faces, edges and vertices of each type of pyramid:

i) Pentagonal pyramid

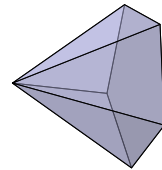

ii) Hexagonal pyramid

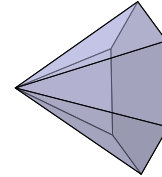

iii) Heptagonal pyramid

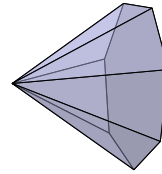

b) A pyramid has a base with  $n$  sides. Select the correct expressions for the pyramid's:

i) number of faces

$n + 1$

ii) number of edges

$n + 2$

$n + 5$

$2n$

$n + 1$

# Fluency Practice

3. a) State the number of faces, edges and vertices of each type of prism:

i) Pentagonal prism

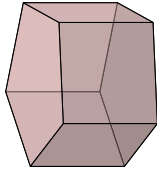

ii) Hexagonal prism

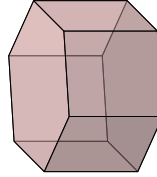

iii) Heptagonal prism

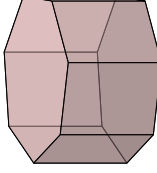

b) The cross-section of a prism is a polygon with  $n$  sides.  
Write expressions for the prism's:

i) number of faces

ii) number of edges

iii) number of vertices

4. Here are four shapes with curved faces:

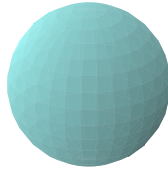

Sphere

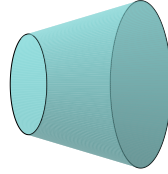

Frustum

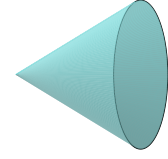

Cone



Cylinder

a) Which of the shapes have no edges?

b) Which of the shapes have no vertices?

c) Which two of the shapes have the same number of faces, edges and vertices?

5. a) Work out how many faces, edges and vertices the octahedron in the diagram has.

Octahedron

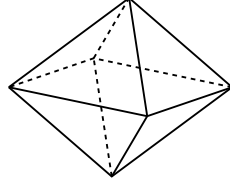

Square-based pyramid

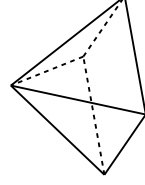

b) Kim says: "The square-based pyramid is half of the octahedron, so it has half as many faces, edges and vertices."  
Is Kim correct?

6. For any 3d shape, the number of faces  $F$ , edges  $E$  and vertices  $V$  are always connected by the formula  $V - E + F = 2$ .

a) Rearrange the formula to make  $V$  the subject.

b) Rearrange the formula to make  $E$  the subject.

c) A shape has 9 faces and 16 edges. Work out how many vertices the shape has.

d) A shape has 4 faces and 4 vertices. Work out how many edges the shape has.

# Fluency Practice

For each of the 3D shapes shown, write down the number of faces, vertices and edges.

(a)

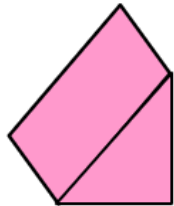

(b)

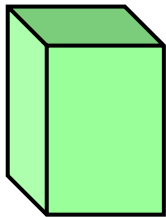

(c)

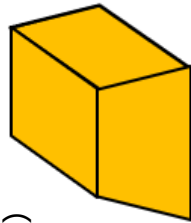

(d)

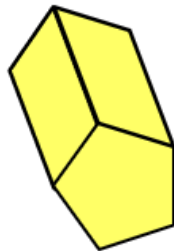

Complete the table for the 3D shapes.

3D Shape	Faces	Vertices	Edges
Cube			
Hexagonal Prism			
Square-based Pyramid			
Tetrahedron			
Octahedron			

For each shape shown, write down the number of flat faces, curved surfaces, edges and vertices.

(a)

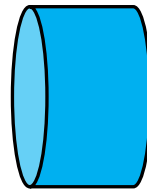

(b)

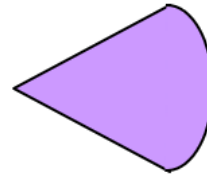

(c)

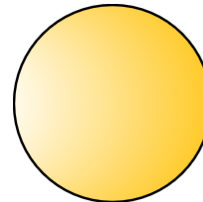

(d)

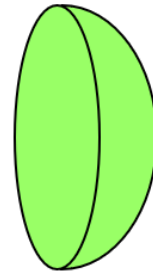

# Fluency Practice

Some sketches of 3D shapes have been started for you.

Complete each shape (no need to be accurate!) then count the **Faces, Edges & Vertices**

## Describing Polyhedra

(plural of 'polyhedron' – 'many' 'bases')

A 3D shape with flat sides.

plural of vertex

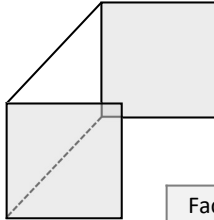

**Cuboid**

Faces	
Edges	
Vertices	

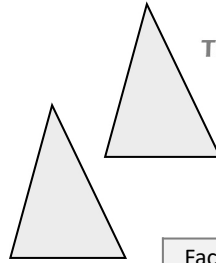

**Triangular Prism**

Faces	
Edges	
Vertices	

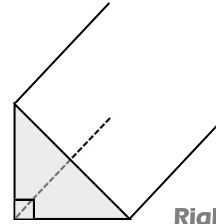

**Right-Angled Triangular Prism**

Faces	
Edges	
Vertices	

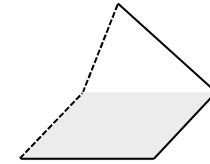

**Square-Based Pyramid**

Faces	
Edges	
Vertices	

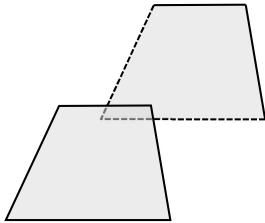

**Trapezium-Based Prism**

Faces	
Edges	
Vertices	

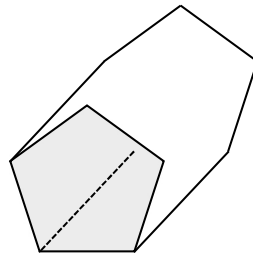

**Pentagonal Prism**

Faces	
Edges	
Vertices	

**Triangle-Based Pyramid (Tetrahedron)**

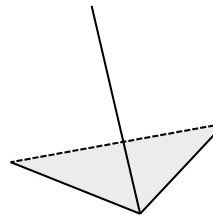

Faces	
Edges	
Vertices	

Faces	
Edges	
Vertices	

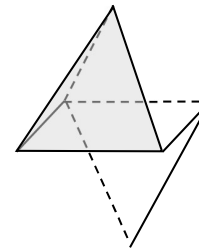

**Octahedron**

Faces	
Edges	
Vertices	

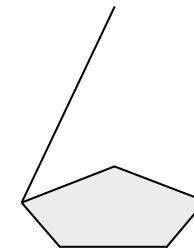

**Pentagonal Pyramid**

Is there a **formula** that connects the faces, edges & vertices of a polyhedron?



# Extension

(1)

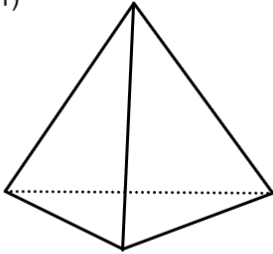

$$F =$$
$$V =$$
$$E =$$

(2)

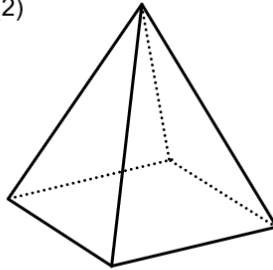

$$F =$$
$$V =$$
$$E =$$

(3)

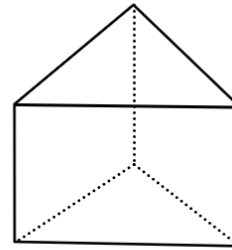

$$F =$$
$$V =$$
$$E =$$

(4)

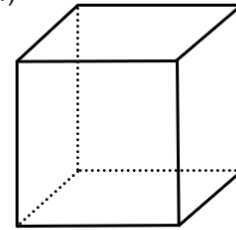

$$F =$$
$$V =$$
$$E =$$

(5)

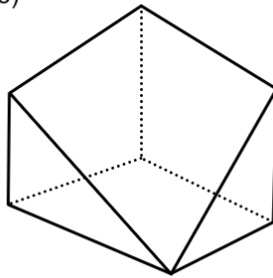

$$F =$$
$$V =$$
$$E =$$

(6)

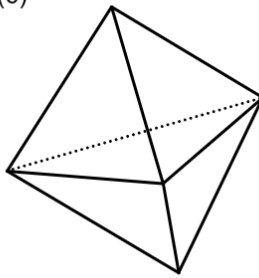

$$F =$$
$$V =$$
$$E =$$

(7)

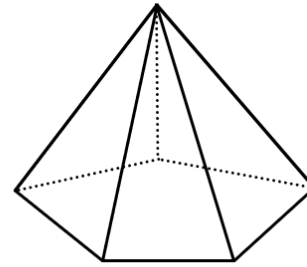

$$F =$$
$$V =$$
$$E =$$

(8)

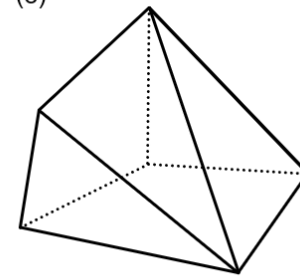

$$F =$$
$$V =$$
$$E =$$

# Extension

(9)

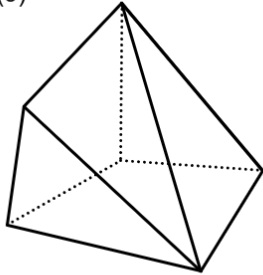

$$\begin{aligned} F &= \\ V &= \\ E &= \end{aligned}$$

(10)

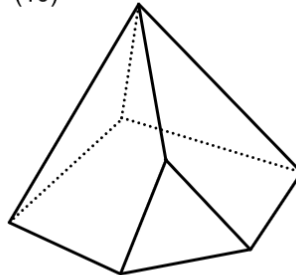

$$\begin{aligned} F &= \\ V &= \\ E &= \end{aligned}$$

(11)

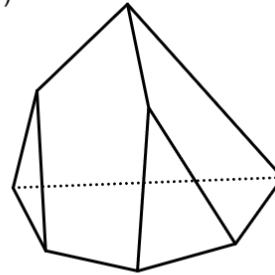

$$\begin{aligned} F &= \\ V &= \\ E &= \end{aligned}$$

(12)

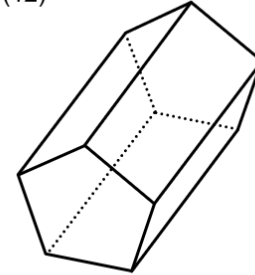

$$\begin{aligned} F &= \\ V &= \\ E &= \end{aligned}$$

(13)

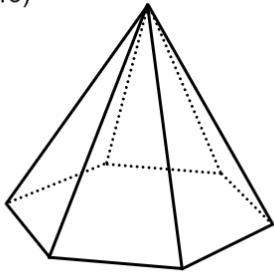

$$\begin{aligned} F &= \\ V &= \\ E &= \end{aligned}$$

(14)

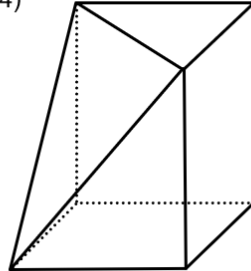

$$\begin{aligned} F &= \\ V &= \\ E &= \end{aligned}$$

(15)

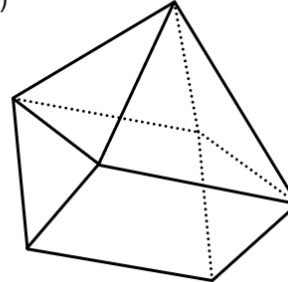

$$\begin{aligned} F &= \\ V &= \\ E &= \end{aligned}$$

(16)

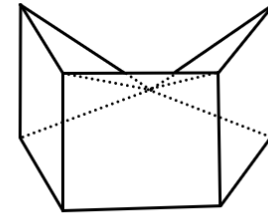

$$\begin{aligned} F &= \\ V &= \\ E &= \end{aligned}$$

## Extension

pair off the polyhedra with the same  $F$ ,  $V$ ,  $E$  values (i)

(1)

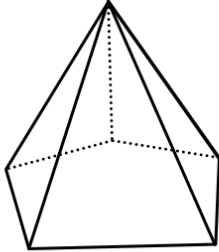

$$\begin{aligned} F &= \\ V &= \\ E &= \end{aligned}$$

(2)

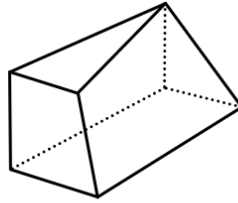

$$\begin{aligned} F &= \\ V &= \\ E &= \end{aligned}$$

(3)

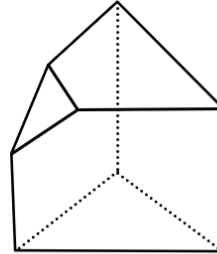

$$\begin{aligned} F &= \\ V &= \\ E &= \end{aligned}$$

(4)

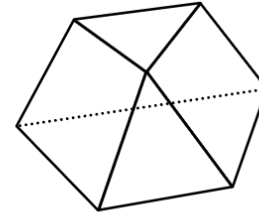

$$\begin{aligned} F &= \\ V &= \\ E &= \end{aligned}$$

(5)

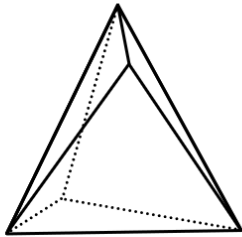

$$\begin{aligned} F &= \\ V &= \\ E &= \end{aligned}$$

(6)

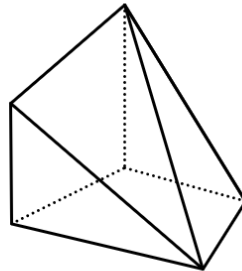

$$\begin{aligned} F &= \\ V &= \\ E &= \end{aligned}$$

(7)

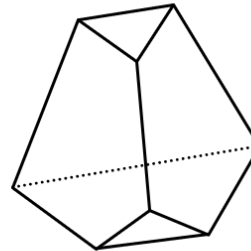

$$\begin{aligned} F &= \\ V &= \\ E &= \end{aligned}$$

(8)

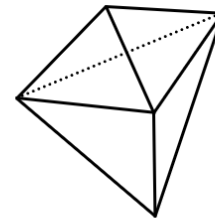

$$\begin{aligned} F &= \\ V &= \\ E &= \end{aligned}$$

## Extension

pair off the polyhedra with the same  $F$ ,  $V$ ,  $E$  values (ii)

(1)

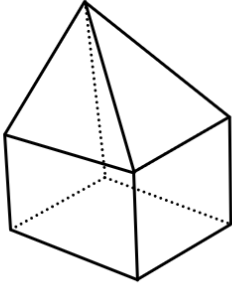

$$\begin{aligned} F &= \\ V &= \\ E &= \end{aligned}$$

(2)

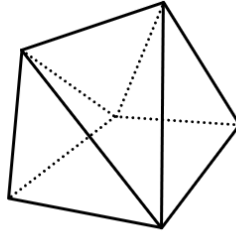

$$\begin{aligned} F &= \\ V &= \\ E &= \end{aligned}$$

(3)

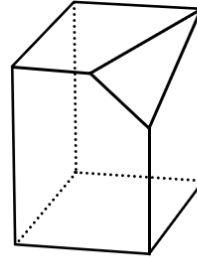

$$\begin{aligned} F &= \\ V &= \\ E &= \end{aligned}$$

(4)

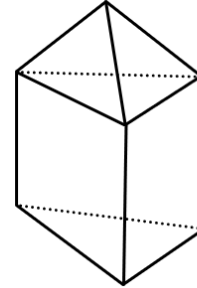

$$\begin{aligned} F &= \\ V &= \\ E &= \end{aligned}$$

(5)

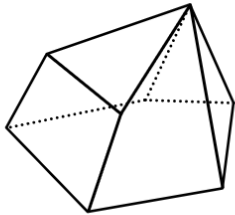

$$\begin{aligned} F &= \\ V &= \\ E &= \end{aligned}$$

(6)

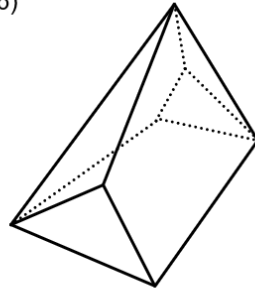

$$\begin{aligned} F &= \\ V &= \\ E &= \end{aligned}$$

(7)

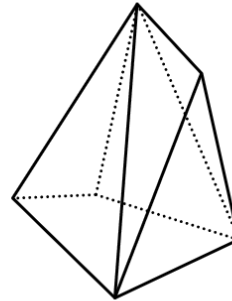

$$\begin{aligned} F &= \\ V &= \\ E &= \end{aligned}$$

(8)

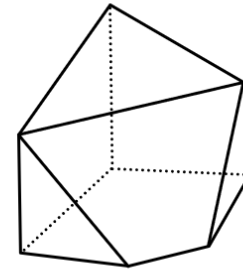

$$\begin{aligned} F &= \\ V &= \\ E &= \end{aligned}$$

# Fluency Practice

Question 1: Draw the nets for these 3D shapes

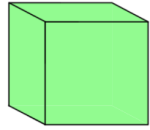

(a)

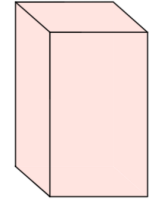

(b)

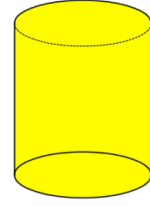

(c)

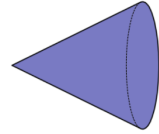

(d)

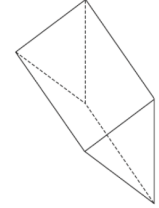

(e)

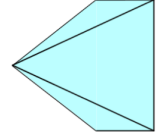

(f)

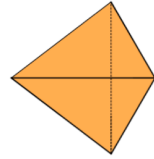

(g)

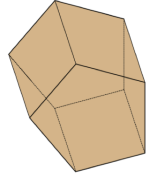

(h)

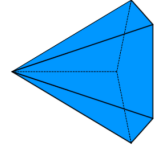

(i)

Question 2: Below are nets for various 3D shapes. Name the 3D shapes.

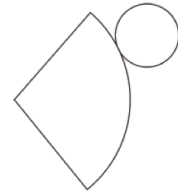

(a)

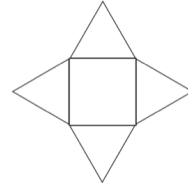

(b)

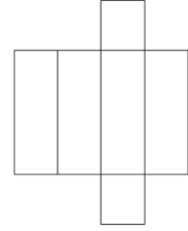

(c)

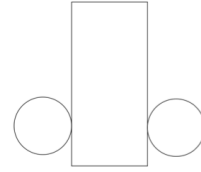

(d)

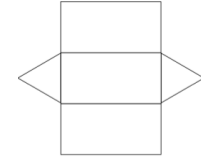

(e)

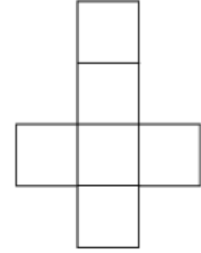

(f)

# Fluency Practice

Question 3: Draw accurate nets for these 3D shapes on squared paper.

(a)

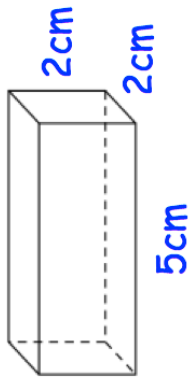

(b)

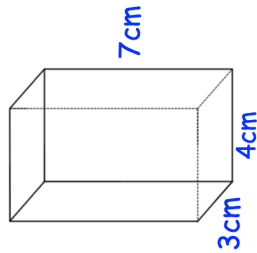

(c)

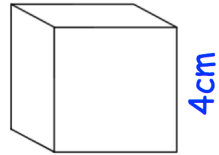

(d)

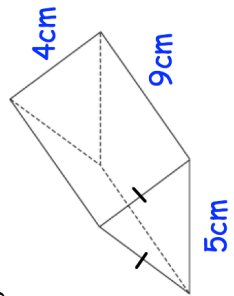

Question 4: Shown below is a square-based pyramid and a tetrahedron. Draw accurate nets for these 3D shapes on squared paper.

(a)

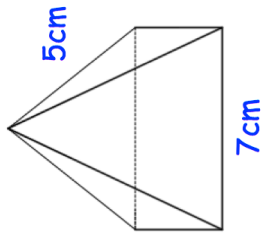

(b)

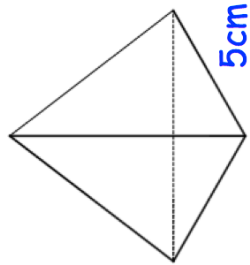

Question 5: The solids on 1cm isometric grids. Draw their nets on squared paper.

(a)

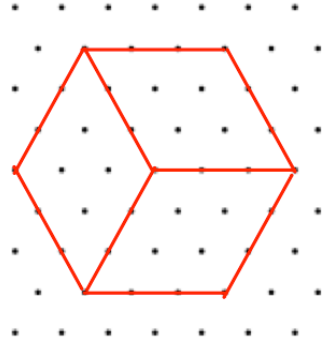

(b)

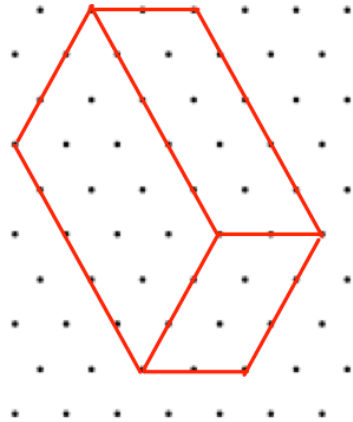

# Extension

Question 1: Shown below is a net for a cube. Draw all the other possible nets for a cube.

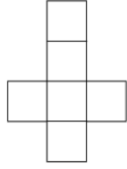

Question 2: Shown below is a net for a square-based pyramid. Draw all other possible nets for a square-based pyramid.

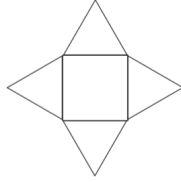

Question 3: Can you spot any mistakes below?

Shown below is a cuboid.



Draw a net for the cuboid.

Each square represents 1cm<sup>2</sup>

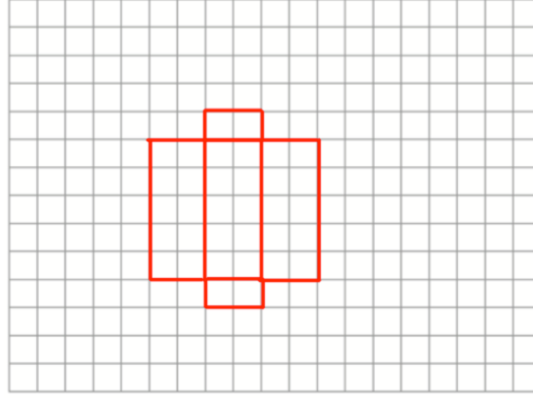

# Fluency Practice

## NETS

Create an appropriate **scale** on grid paper & draw **nets** for these 3D shapes.

not to scale

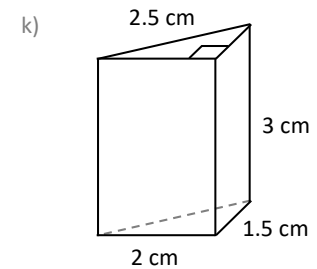
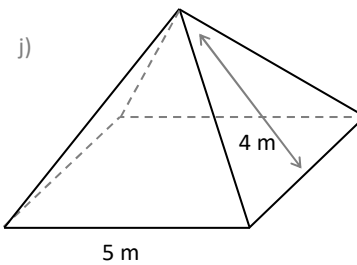
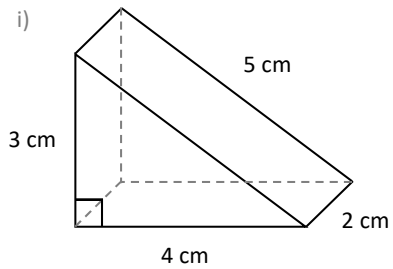
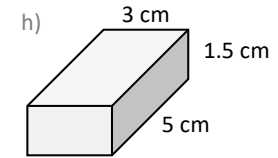
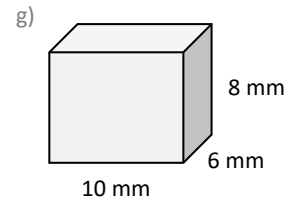
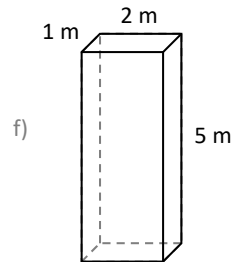
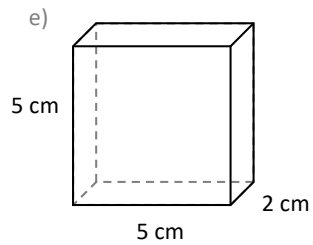
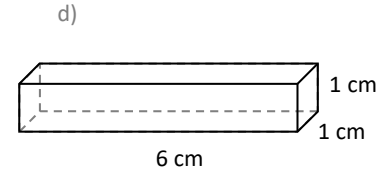
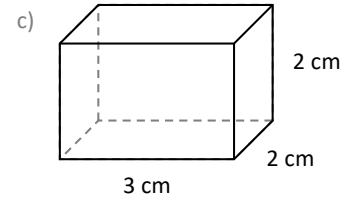
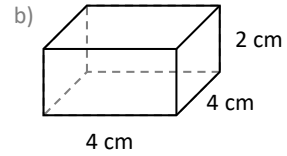
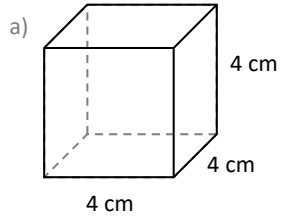



# Fluency Practice



## RAT Prisms

These solid shapes are prisms with a **Right-Angled Triangle** for a base.  
**Sketch the net** for each 3D shape & label any **missing lengths**.

NOT DRAWN  
 ACCURATELY

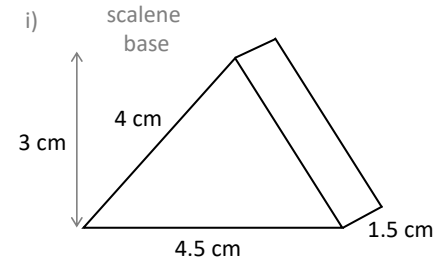
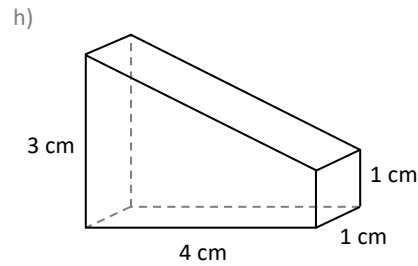
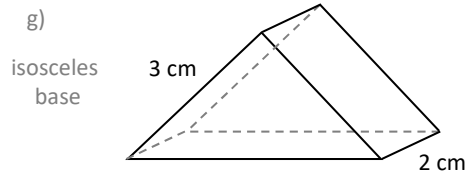
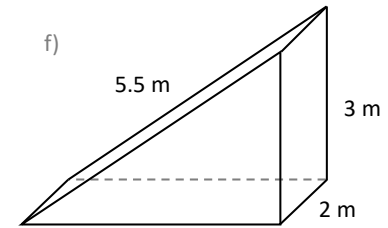
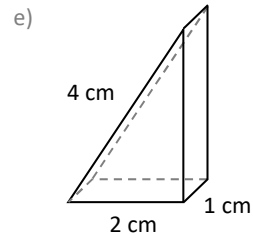
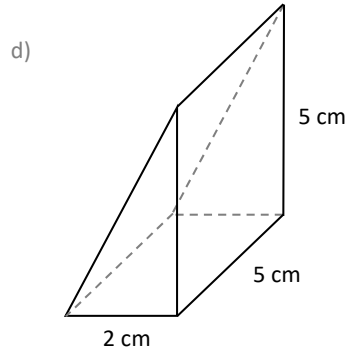
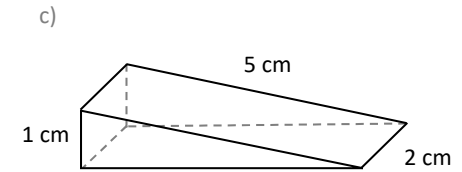
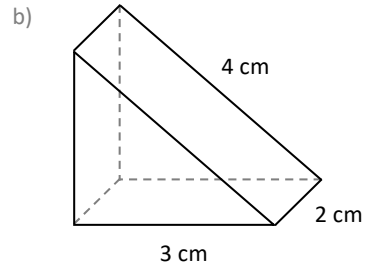
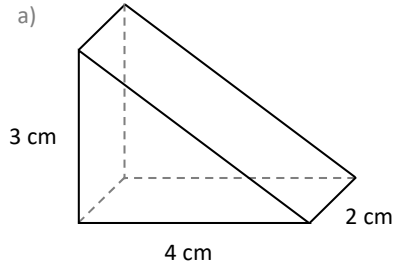

# Fluency Practice

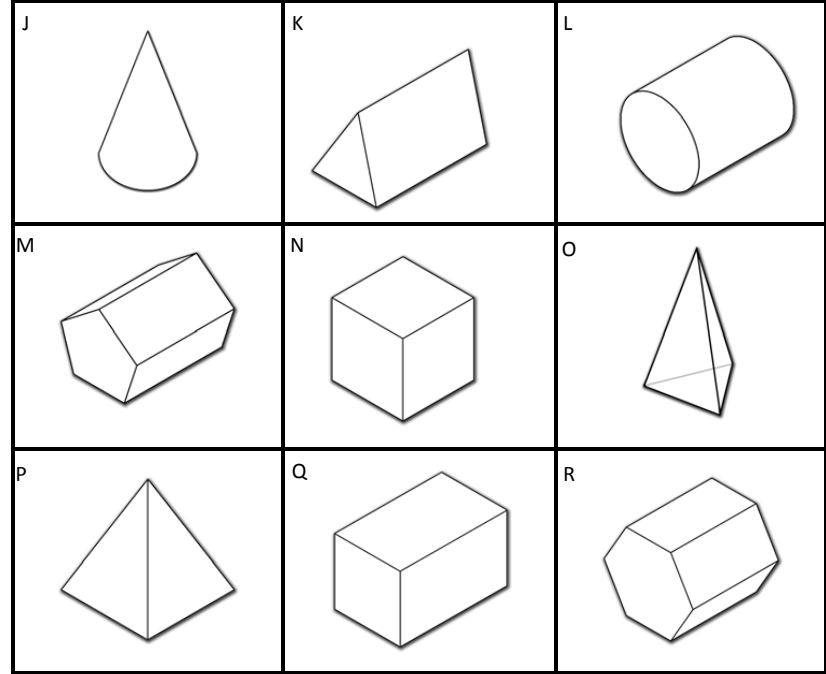
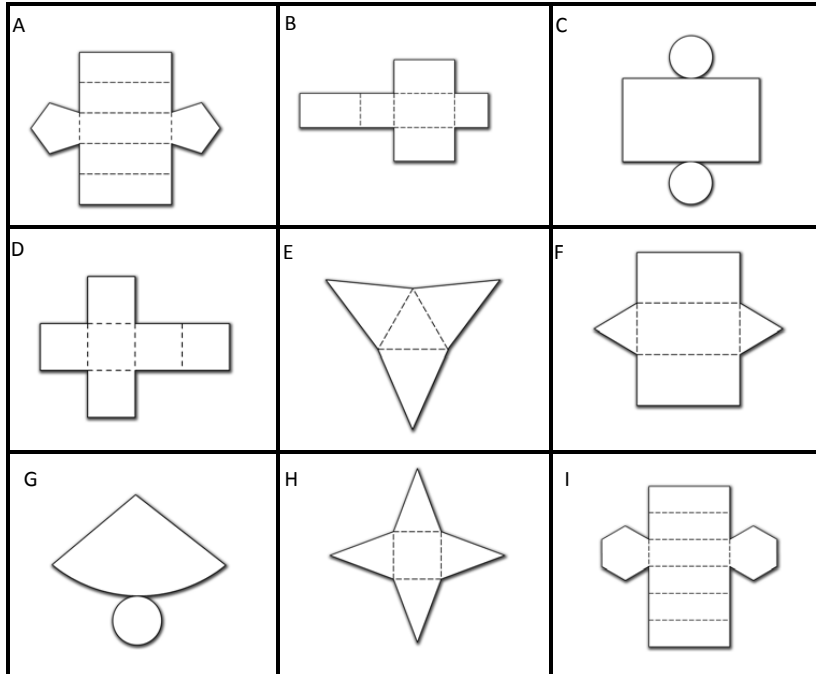

Net	A	B	C	D	E	F	G	H	I
Solid									
Name?									
Faces									
Vertices									
Edges									

## Extension

Which four of these are not real nets of a cube?

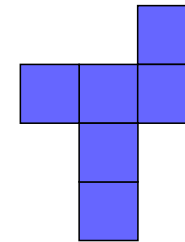
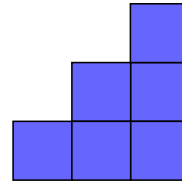
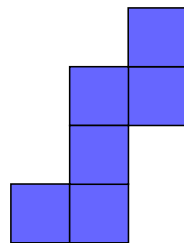
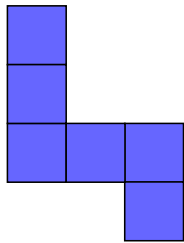
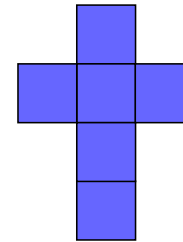
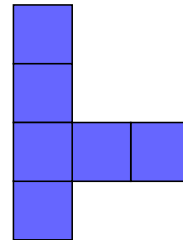
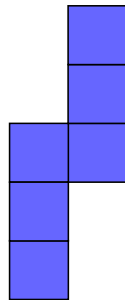
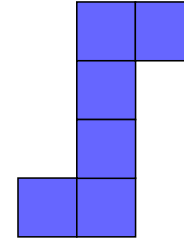
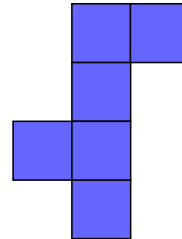
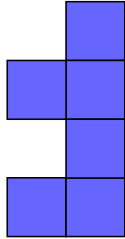
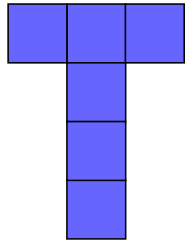

### 3 Plans and Elevations

The **plan** is the view from the top of a 3D solid.

**Elevations** are horizontal views of a 3D object:

- **Front elevation:** The view from the front of an object.
- **Back elevation:** The view from behind the object.
- **Side elevation:** The view from the side of an object.

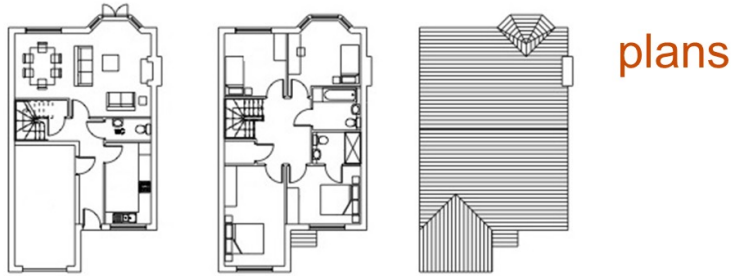

front  
elevation

side  
elevation

back  
elevation

side  
elevation

# Extension

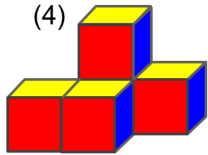
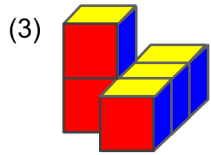
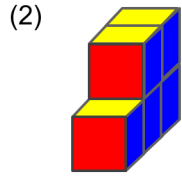
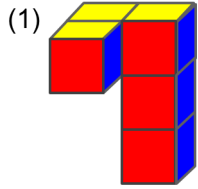

match the solid to the correct plan and elevation

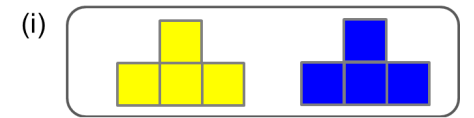
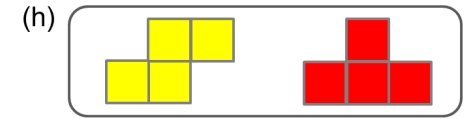
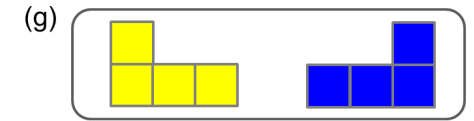
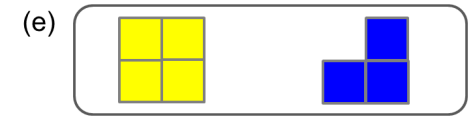
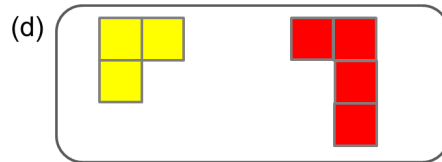
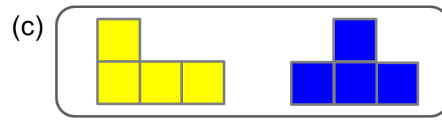
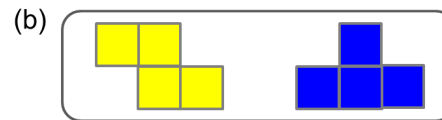
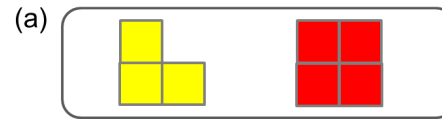
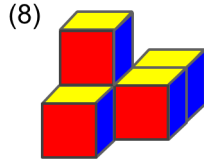
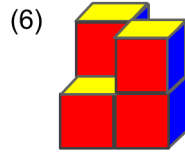
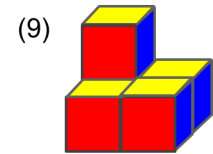
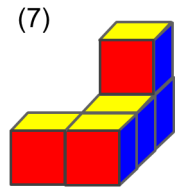
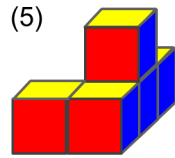

# Fluency Practice

**2** The table below shows the plan, front and side view for a cube or cuboid. Add the dimensions of the shape to the original shape. The first one has been done for you.

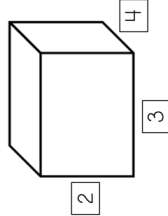
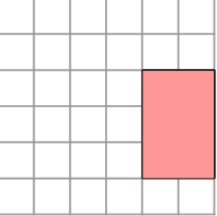
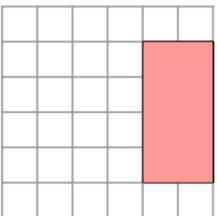
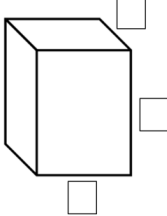
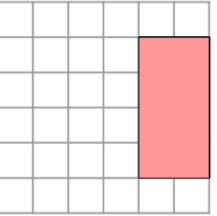
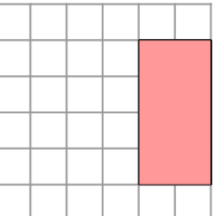
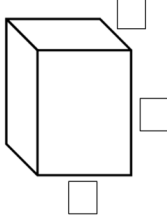
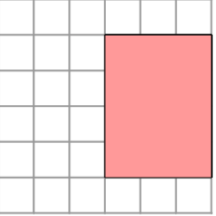
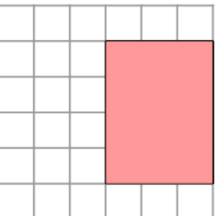
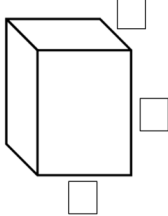
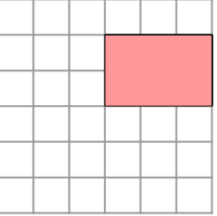
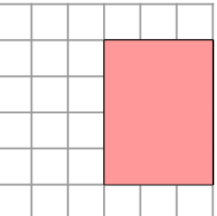
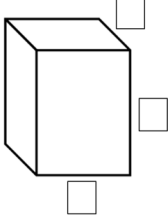
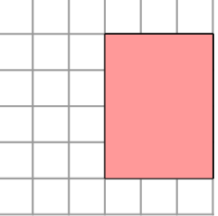
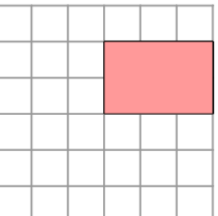
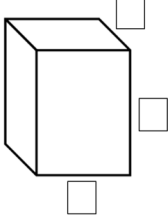
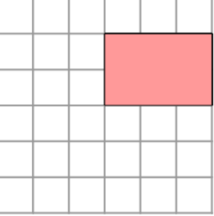
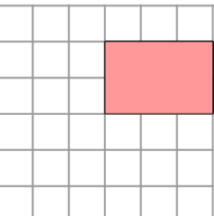
	Plan View	Front View	Side View
<b>E</b> <b>x</b> <b>a</b> <b>m</b> <b>p</b> <b>l</b> <b>e</b>			
<b>a</b>			
<b>b</b>			
<b>c</b>			
<b>d</b>			
<b>e</b>			

Describe what happened to the shape from part **c** to part **d**.

**f** \_\_\_\_\_

# Fluency Practice

## Counting Cubes

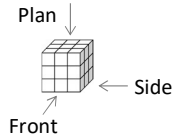

The plans & elevations for different shapes are shown.

How many cubes are in each shape?

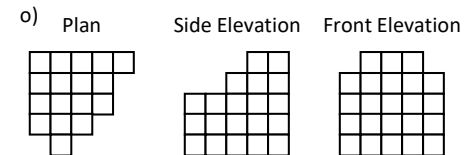
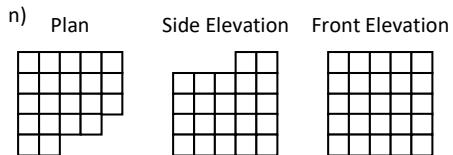
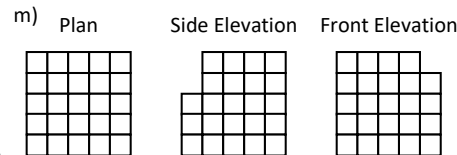
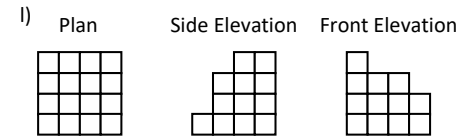
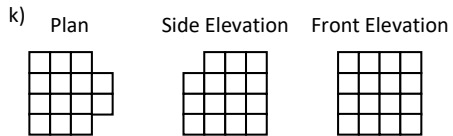
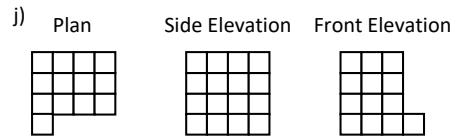
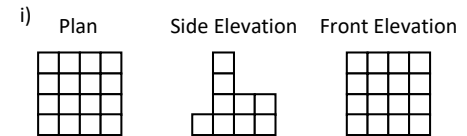
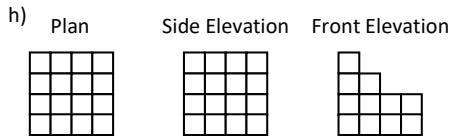
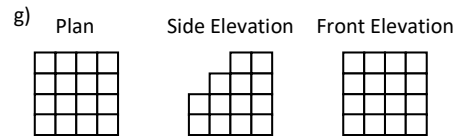
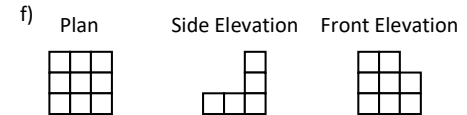
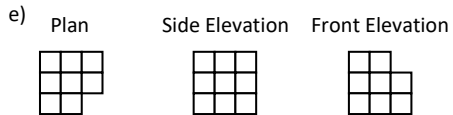
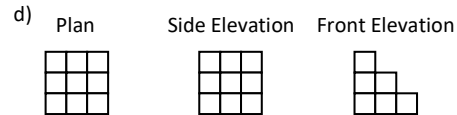
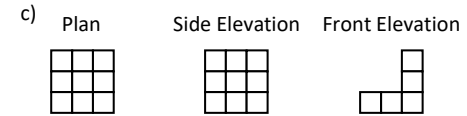
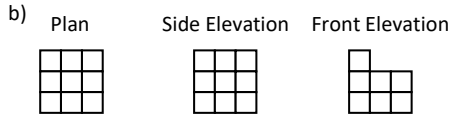
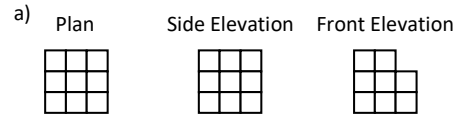

## 4 Volume and Surface Area of Prisms



# Fluency Practice

Prism or Pyramid?

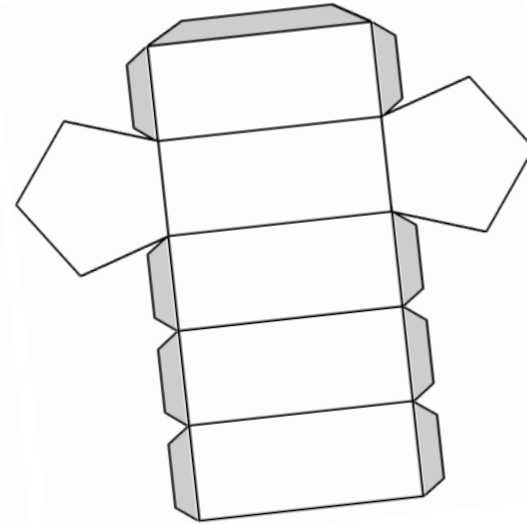
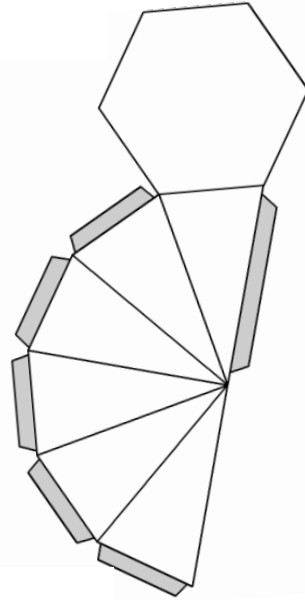
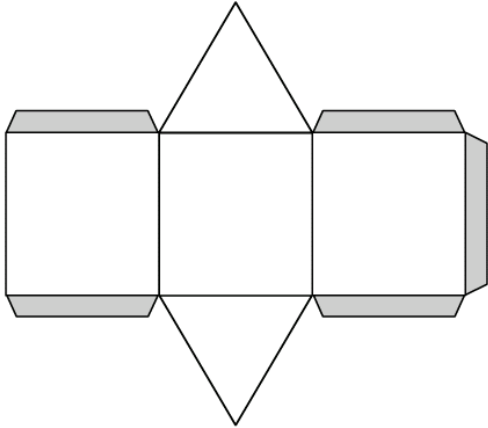

Cuboid	Cone
Pentagonal prism	Tetrahedron (triangle based pyramid)
Square based pyramid	Hexagonal prism
Rhombic prism	Pentagonal pyramid
Hexagonal pyramid	Triangular prism

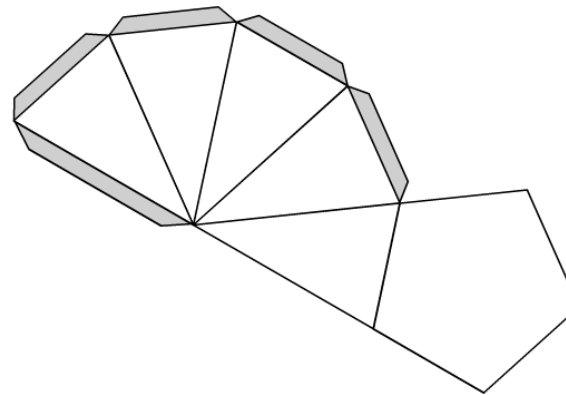

# Fluency Practice

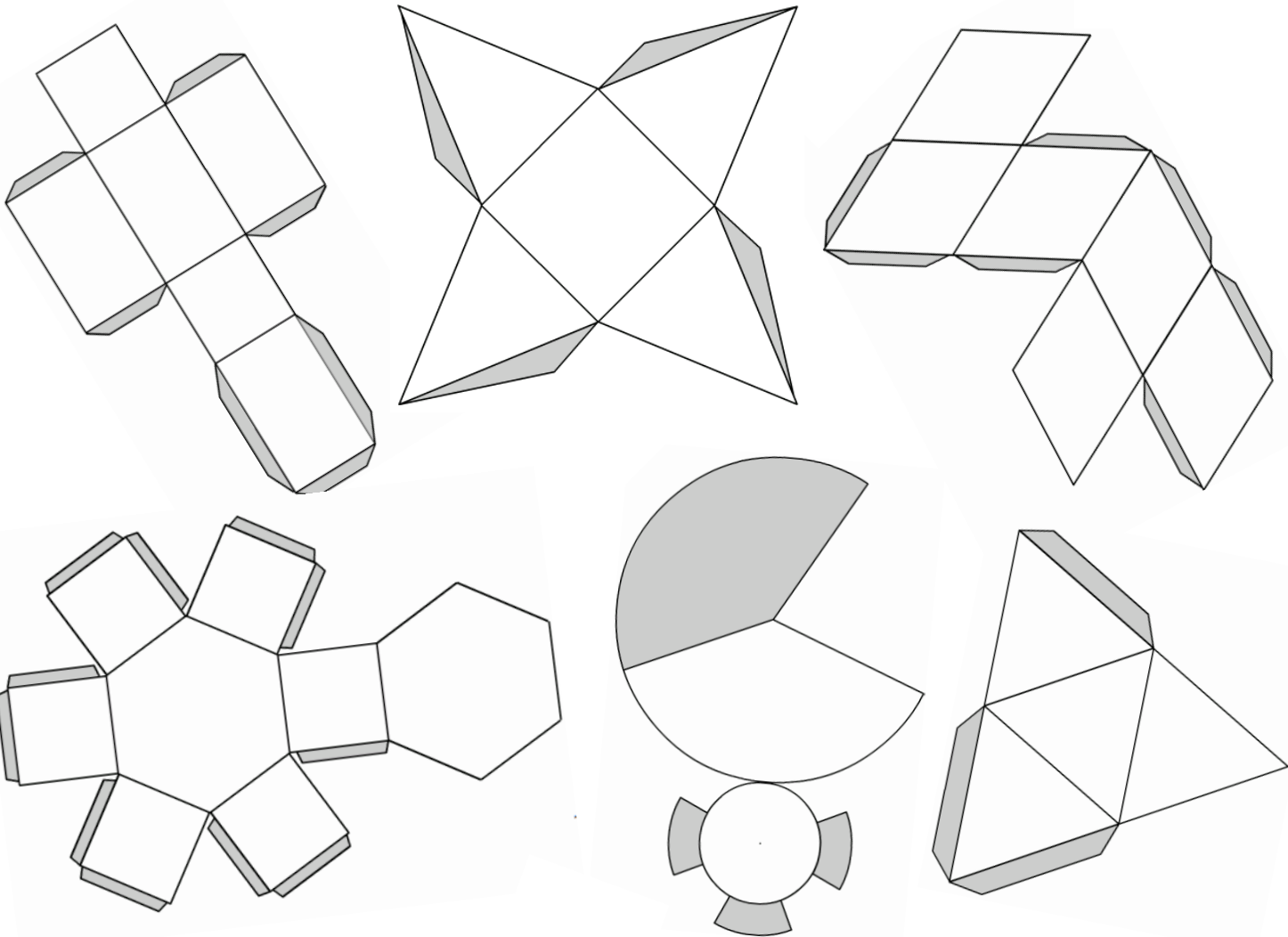

# Fluency Practice

This is a cube with 1 centimetre sides.

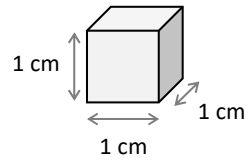

Its volume (inside space) is  $1 \text{ cm}^3$ .

## Volume

These shapes are made from  $1 \text{ cm}^3$  cubes.  
Calculate their **volume**.  
Instead of counting each cube, are there any shortcuts you can take?

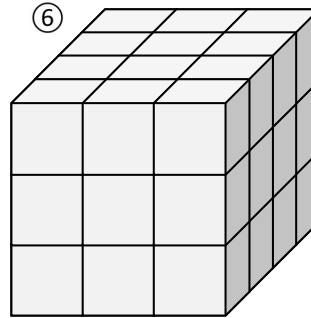
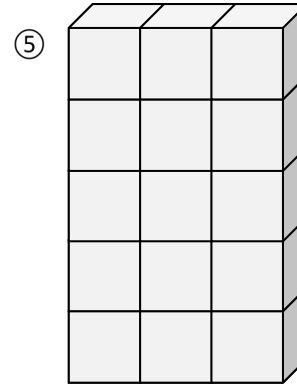
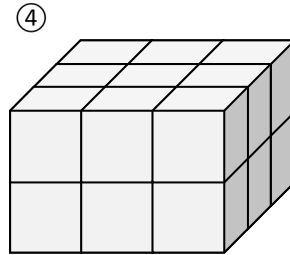
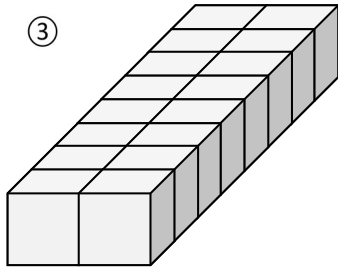
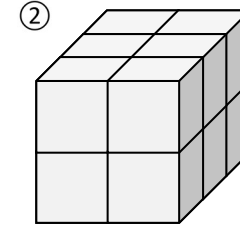
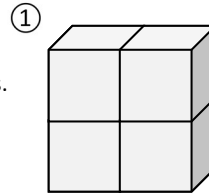

In these shapes only some of the  $1 \text{ cm}^3$  cubes are shown.

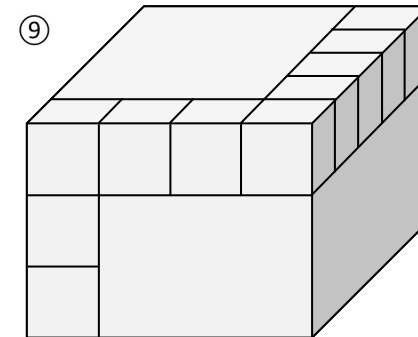
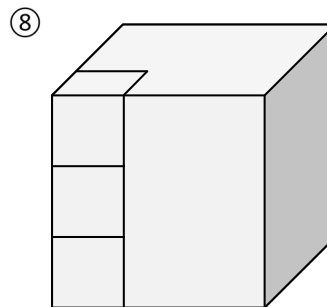
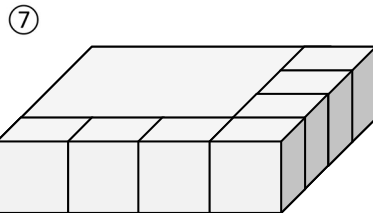

# Fluency Practice

how many cubes?

Assume that each of the cubes in these pictures are 1cm by 1cm by 1cm.  
Calculate the volume of each picture.

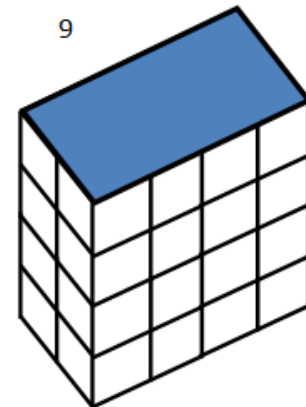
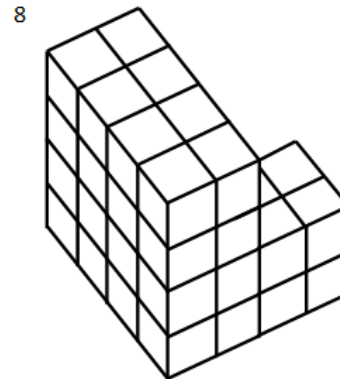
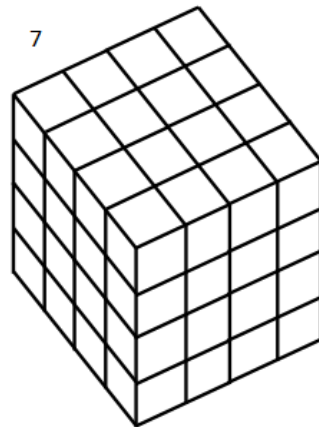
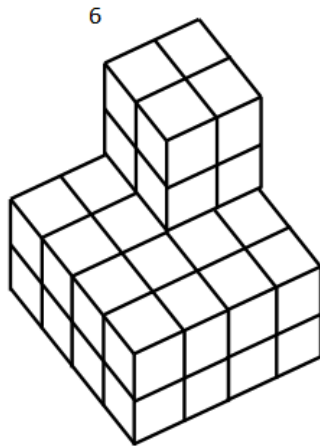
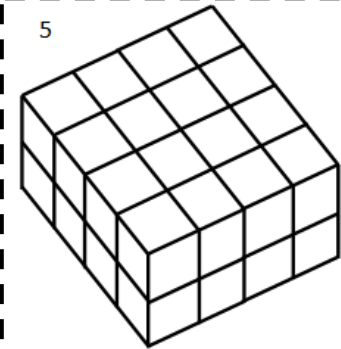
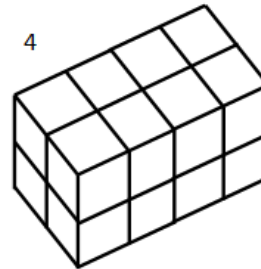
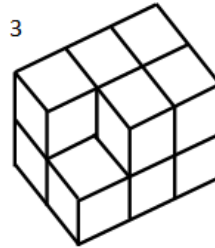
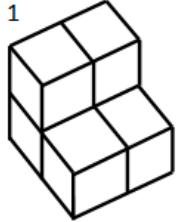

# Fluency Practice

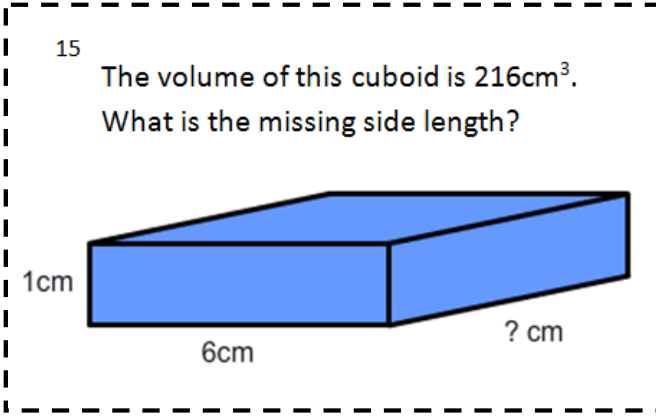
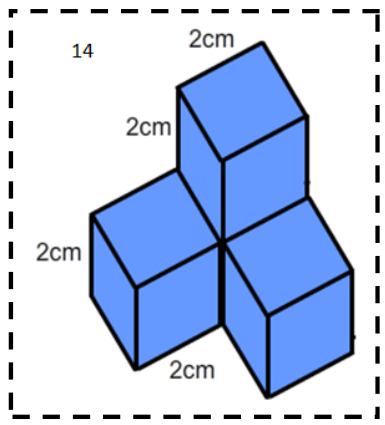
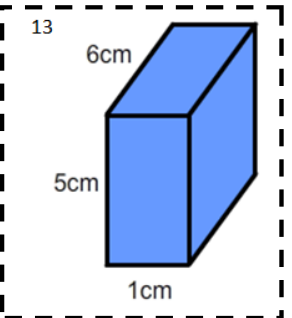
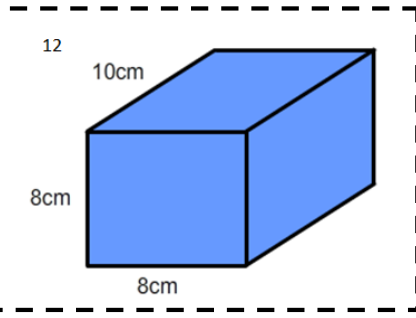
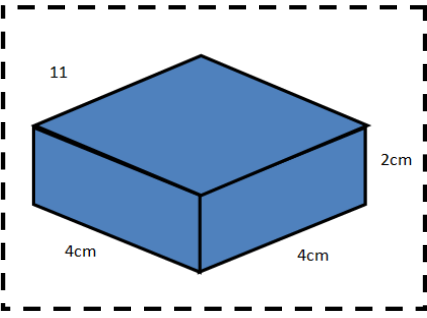
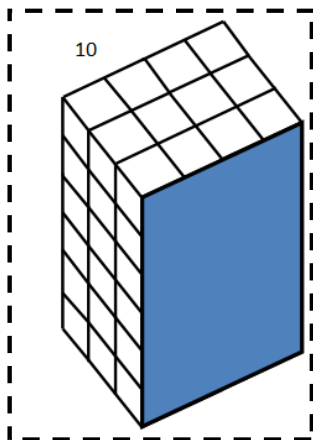

**challenge!**  
design three different cuboids with a volume of exactly  $20\text{cm}^3$ .  
can you make your cuboids out of paper?  
which cuboid uses the least amount of paper?

## Jumbled Up Answers

$6\text{cm}^3$

$32\text{cm}^3$

$32\text{cm}^3$

$40\text{cm}^3$

$36\text{cm}$

$12\text{cm}^3$

$640\text{cm}^3$

$64\text{cm}^3$

$40\text{cm}^3$

$72\text{cm}^3$

$32\text{cm}^3$

$11\text{cm}^3$

$32\text{cm}^3$

$30\text{cm}^3$

# Investigation into... Factors and Volumes

With 12 cubes, you can make 4 different cuboids:



$1 \times 1 \times 12$



$1 \times 2 \times 6$

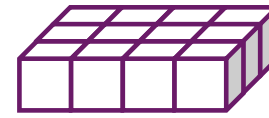

$1 \times 3 \times 4$

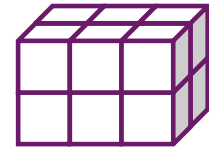

$2 \times 2 \times 3$

12 has 4 non-prime factors: 1, 4, 6, and 12.

*12 has the same number of non-prime factors as there are cuboids made from 12 cubes.*

### **Investigation prompts:**

- How many cuboids can be made from 16 cubes? How many non-prime factors does 16 have?
- Find numbers of cubes that can be made into exactly:
  - 1 cuboid
  - 2 cuboids
  - 3 cuboids
  - 5 cuboids
  - 6 cuboidsHow many non-prime factors do each of your answers have?
- It is **not** always true that the number of non-prime factors is equal to the number of possible cuboids. Find an example that shows this.

# Fluency Practice

Find the volume of each of these cuboids. Include units with your answers.

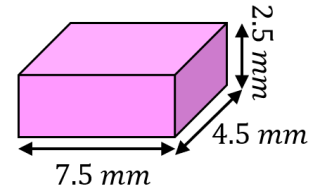
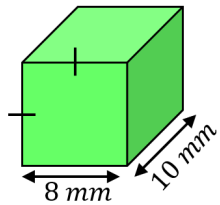
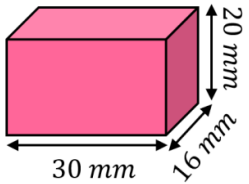
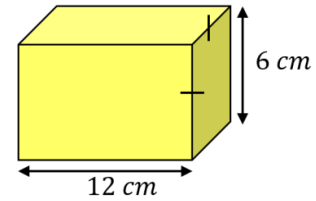
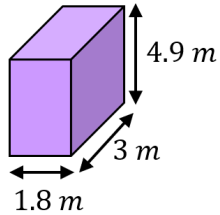
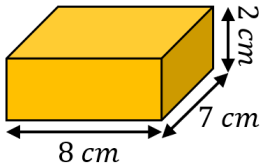
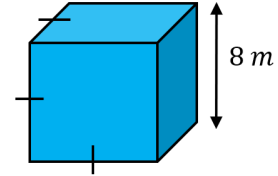
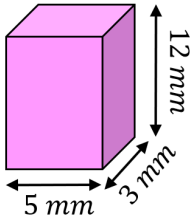
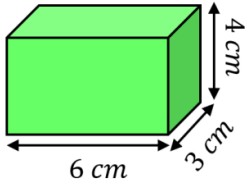

Find the missing measurements in these cuboids.

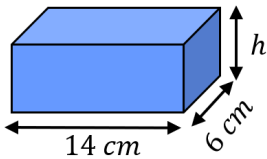

*Volume = 210 cm<sup>3</sup>*

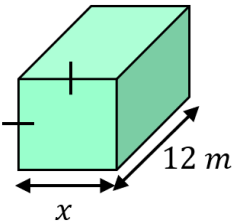

*Volume = 507 m<sup>3</sup>*

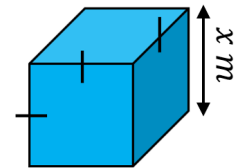

*Volume = 1331 m<sup>3</sup>*

# Fluency Practice

Question 1: Work out the volume of each cuboid.  
Include suitable units.

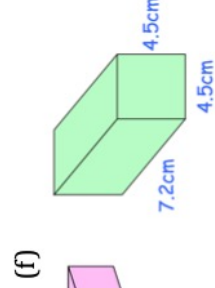
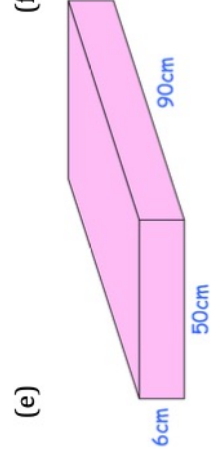
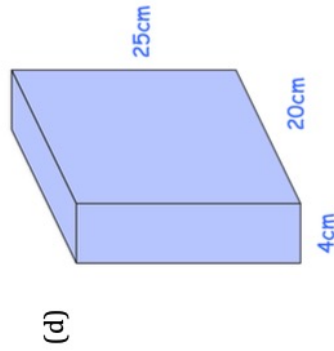
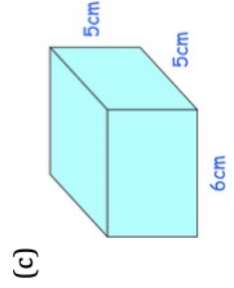
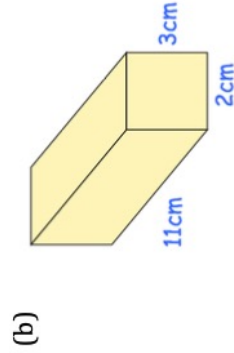
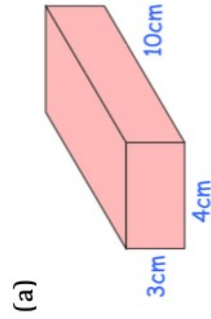

Question 2: Work out the volume of each cube.  
Include suitable units.

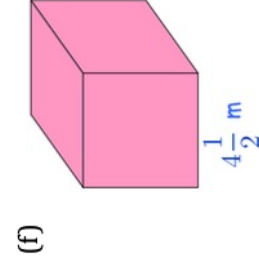
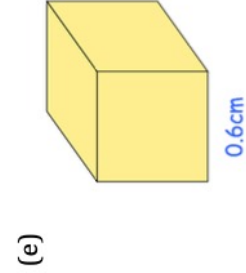
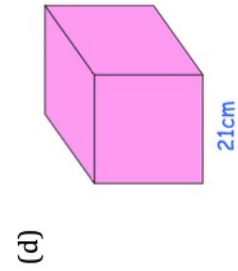
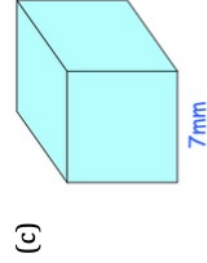
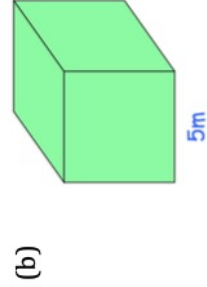
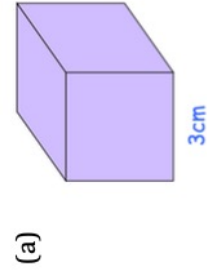



# Fluency Practice

Question 3: Find the length of each cuboid.

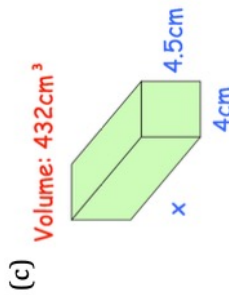
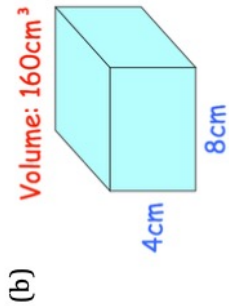
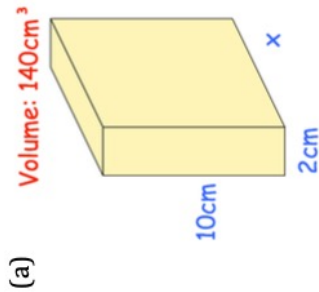

Question 4: For each cuboid below, find the missing measurement, y.

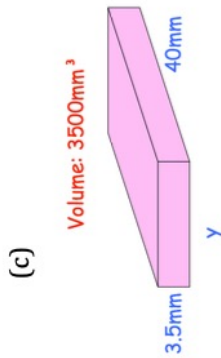
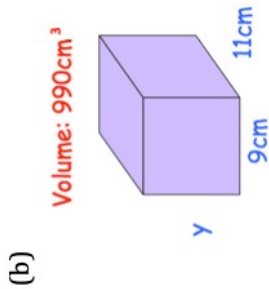
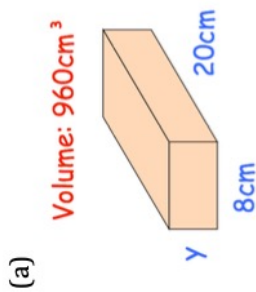

Question 5: The volume of each cube is given.  
Find the length of each side, x.

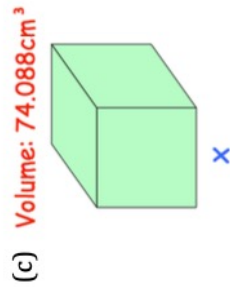
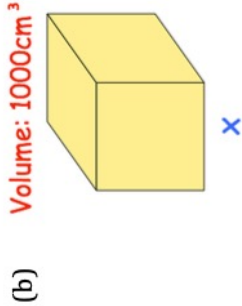
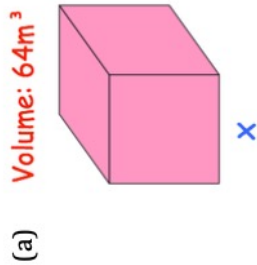

## Extension

Question 1: Find the volume of a water tank that is 80cm long, 40cm wide and 20cm high.

Question 2: A wooden beam measures 4 inches wide by 4 inches high by 60 inches long. Work out the volume of the wooden beam.

Question 3: The cube on the TV show "The Cube" is a cube with each side measuring 4m. Work out the volume of the cube.

Question 4: Both cuboids below have the same volume. Find the height of cuboid B.

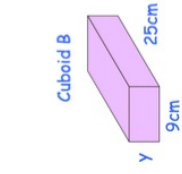
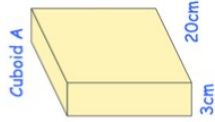

Question 5: The volume of the cube is twice the volume of the cuboid. Find the length of the cuboid.

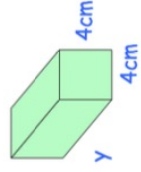
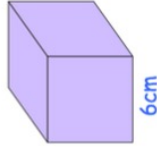

Question 6: The cuboid container below is used to store boxes. Each box is a cube with side length 1m. How many boxes can be stored in the container?

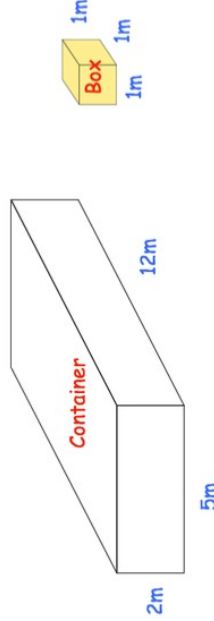

Question 7: The cuboid container below is used to store boxes. Each box is a cube with side length 50cm. How many boxes can be stored in the container?

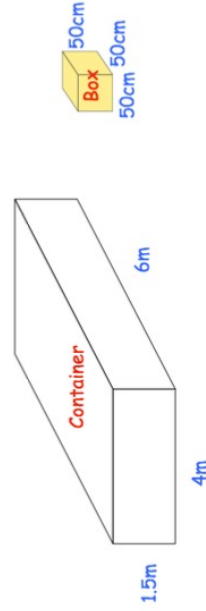

Question 8: An empty swimming pool is going to be filled with water. The swimming pool is a cuboid, that is 25 metres long, 10 metres wide and 2 metres deep. It is being filled at a rate of 800 litres per minute. Given  $1\text{m}^3 = 1000$  Litres, how long it will take to fill the swimming pool? Give your answer in hours and minutes.

## Extension

Question 9: Shown is a net of a cuboid.  
Calculate the volume of the cuboid.

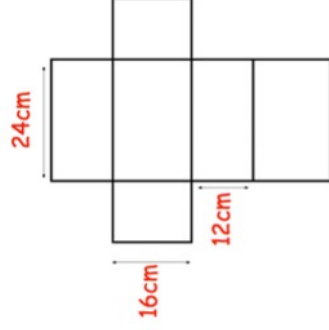

Question 10: A carton of orange juice is shown below.  
The carton is in the shape of a cuboid.

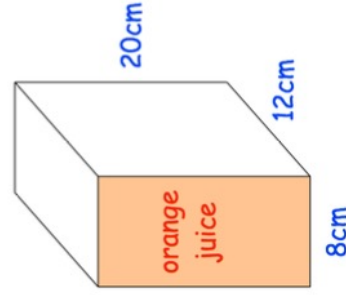

The depth of the orange juice is 6cm.

The carton is turned so that it stands the shaded (orange) face.

Work out the depth of the orange juice now.

Question 11: Peter is making green paint by mixing blue and yellow paint in a cuboid container, shown below.

The container has a width of 30cm and length of 40cm and is full.  
He mixes blue paint and yellow paint in the ratio 2:3.  
Peter uses 8.4 litres of blue paint.

Calculate the height of the container.

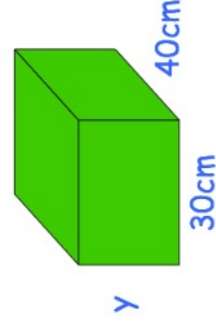

# Problem Solving

Given the volumes of these six cuboids, can you work out the measurements,  $a$ ,  $b$ ,  $c$  and  $d$ ? Explain how you got your answers.

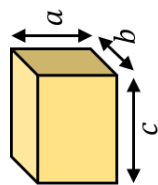

Volume =  $1512 \text{ cm}^3$

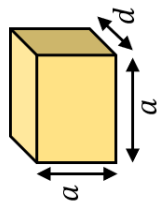

Volume =  $648 \text{ cm}^3$

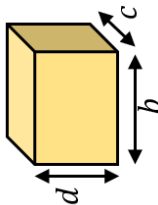

Volume =  $1344 \text{ cm}^3$

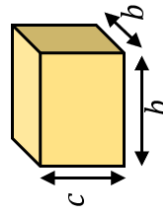

Volume =  $2016 \text{ cm}^3$

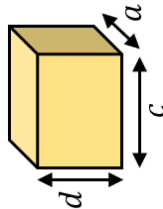

Volume =  $1008 \text{ cm}^3$

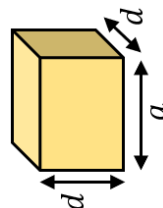

Volume =  $576 \text{ cm}^3$

$a =$

$b =$

$c =$

$d =$

How many more cubes and cuboids can you create using only these four dimensions.  
Find the volume of each cube or cuboid you find.

**CLUE 1**

The order of measurements from smallest to biggest is  $d, a, b, c$

**CLUE 2**

A rectangle with width  $b$  and length  $c$  has an area of  $168 \text{ cm}^2$ .

**CLUE 3**

The volume of a cube with side length  $a$  is  $729 \text{ cm}^3$ .

## Problem Solving

Using digits 0 to 9, without repetition, fill the blanks to create two rectangular prisms with the same volume.

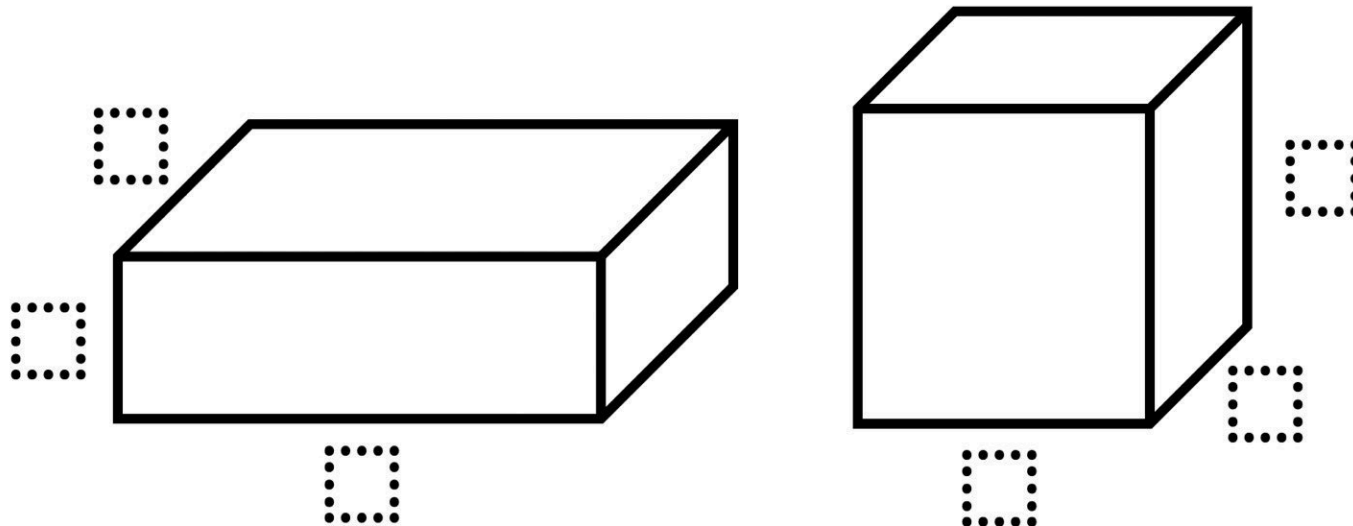

## Problem Solving

Using the numbers 1 to 9, without repetition, can you fill the blanks so that the volumes of these cuboids are equal?  
If not equal, how close can you get?

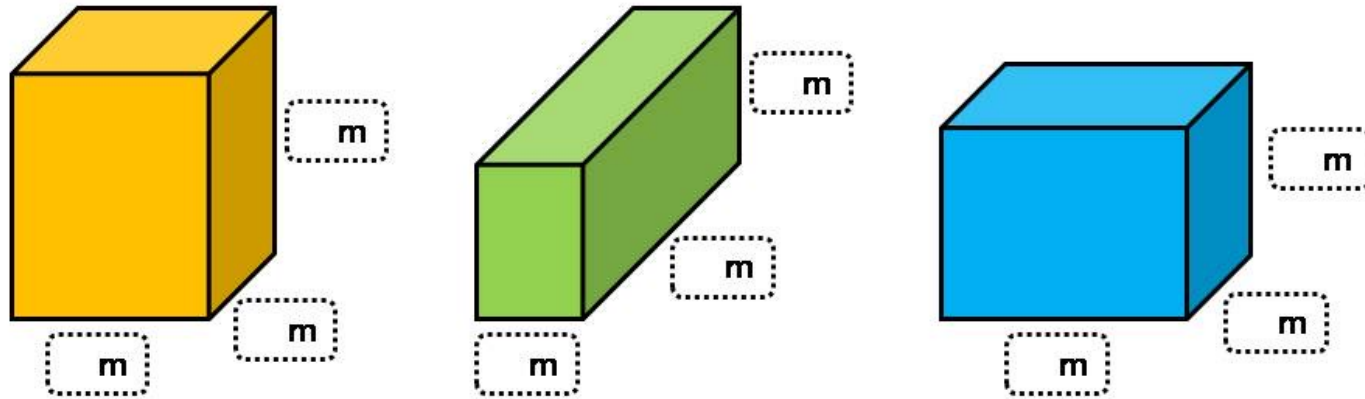

# Fluency Practice

**Q1** Work out the volume of each of the following prisms.

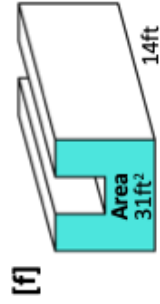
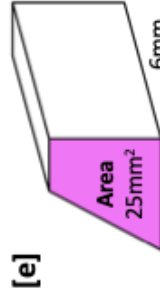
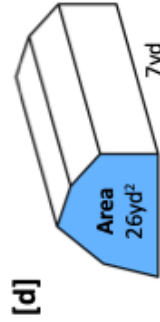
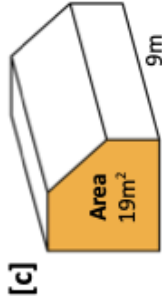
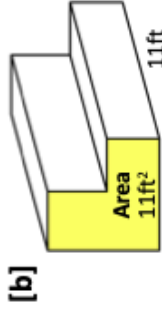
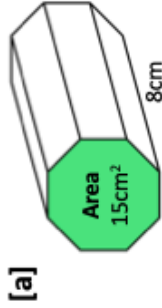

**Q2** Calculate the volume of the following triangular prisms.

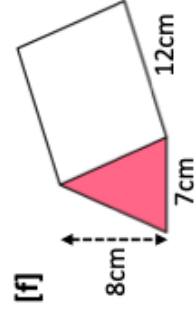
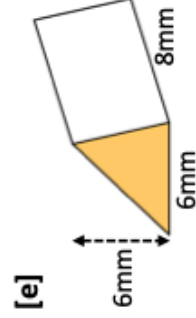
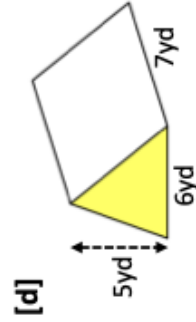
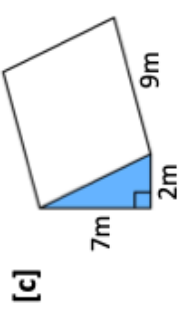
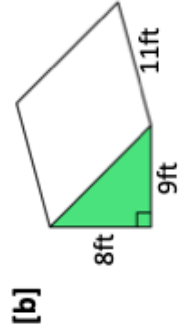
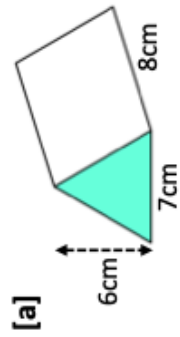

**Q3** Calculate the volume of the following prisms.

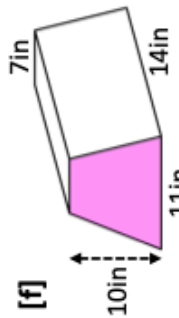
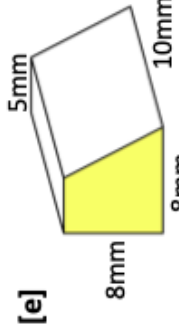
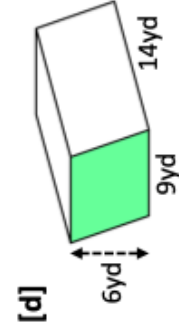
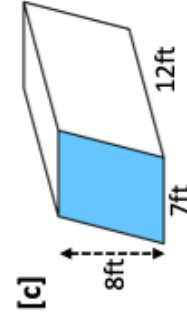
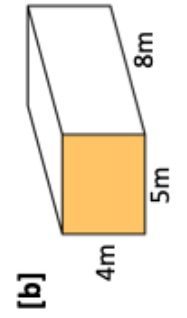
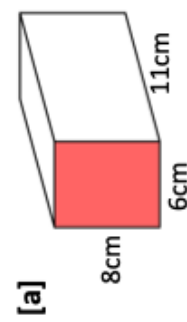

# Fluency Practice

**Q1** Calculate the volume of the following L-shape prisms.

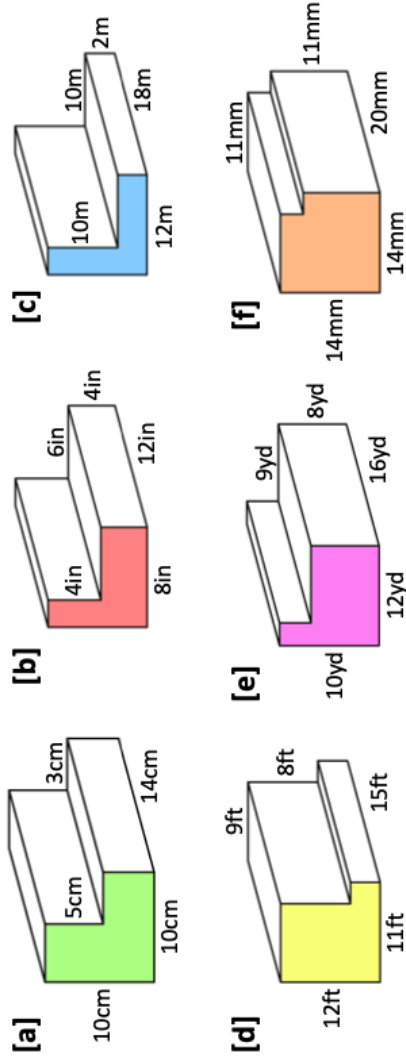

**Q2** Calculate the volume of the following prisms

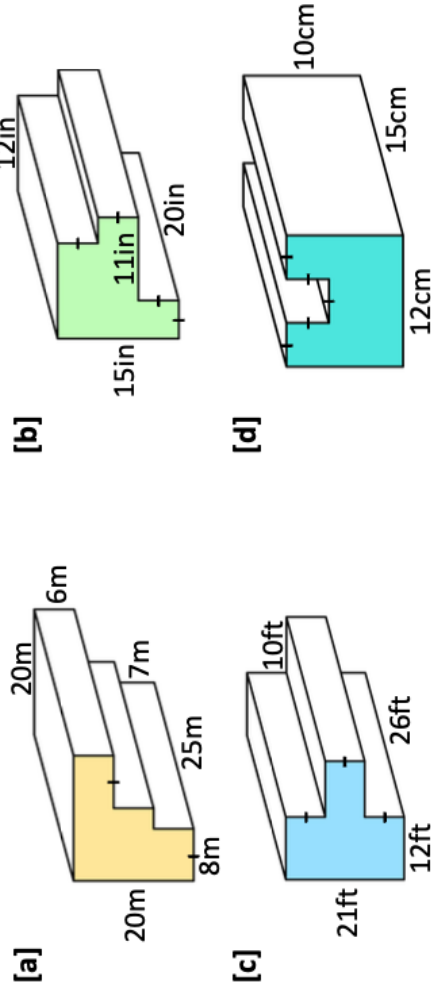

**Q3** Both of the following prisms have the same volume. Find the missing length.

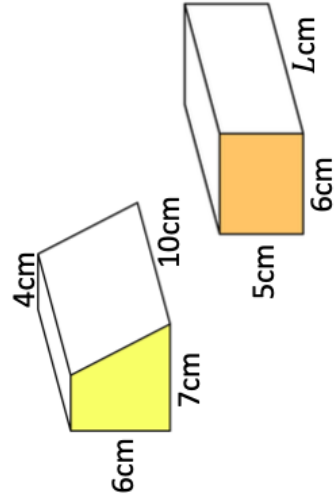

**Q4** 25 kilograms of metal is melted and moulded into prisms. The density of the metal is  $10\text{g}/\text{cm}^3$ . How many prisms can be made?

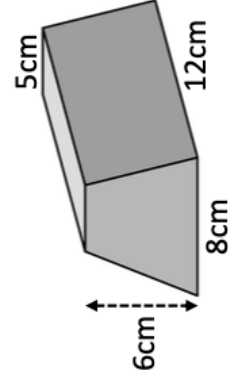



## Fluency Practice

**Q5** Each prism has a volume of  $720\text{cm}^3$ . Find the values of  $a$  and  $b$ .

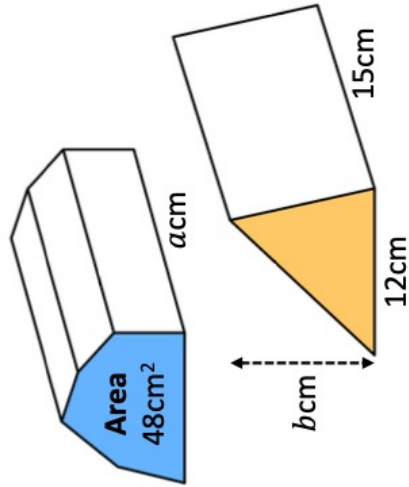

**Q6** Find the ratio of the volume of the triangular prism to the volume of the parallelepiped. Give your answer in its simplest form.

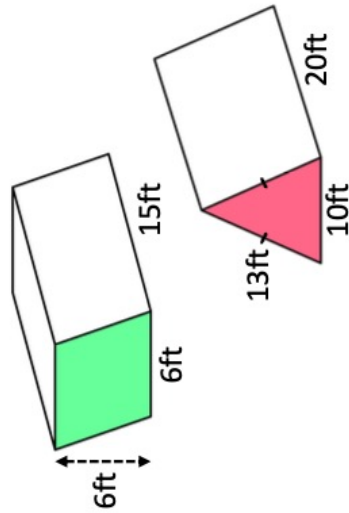

**Q7** Find an expression, in terms of  $x$ , for the volume of the prism. Give your answer in its simplest form.

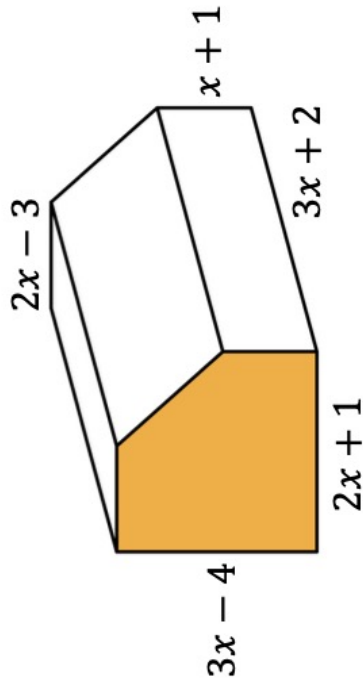

**Q8** Find an expression, in terms of  $x$ , for the volume of the prism. Give your answer in its simplest form.

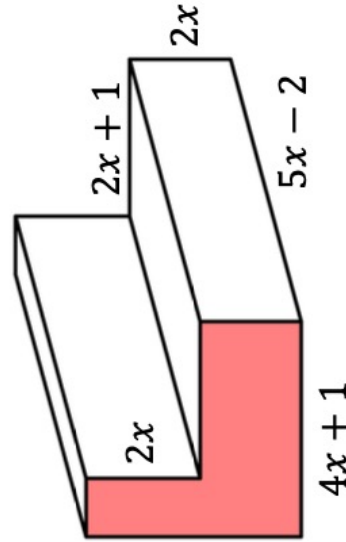

## Fluency Practice

**Q9** Work out the volume of the following prism.

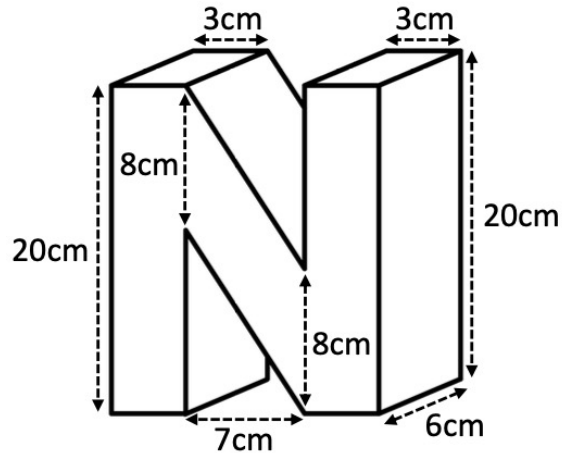

**Q10** A leisure centre's swimming pool is shown below. The swimming pool is empty. A tap is turned on and water flows into the swimming pool at a constant rate. After 20 hours, the water level is 50cm below the top of the pool. Water continues to flow into the pool at the same rate. Work out how much longer it takes to completely fill the pool.

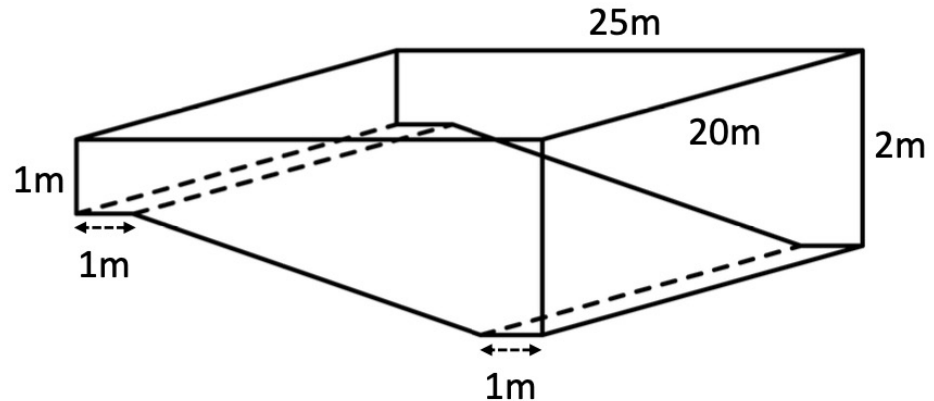

# Fluency Practice

Find the volume of each of these prisms. Include units with your answers.

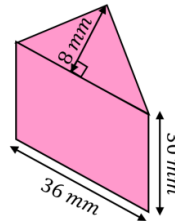
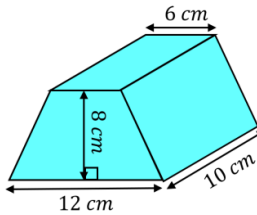
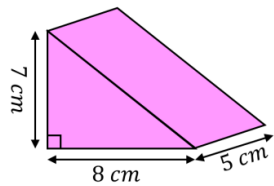
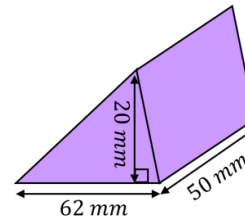
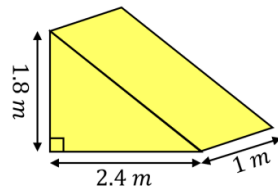
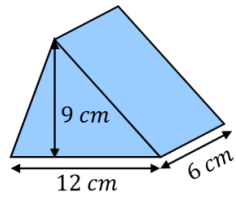
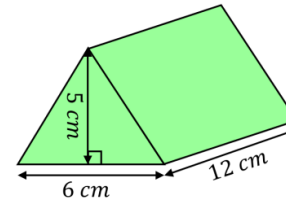
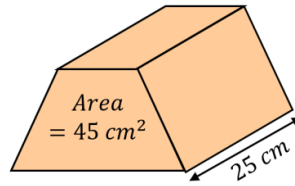
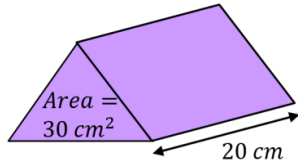

Find the missing measurements in these prisms.

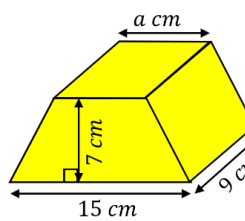
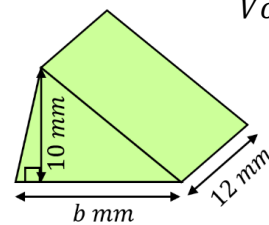
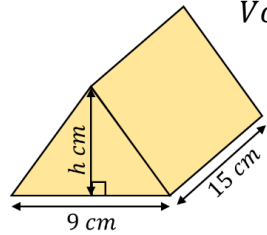

# Fluency Practice

Question 1: Calculate the volume of each prism below

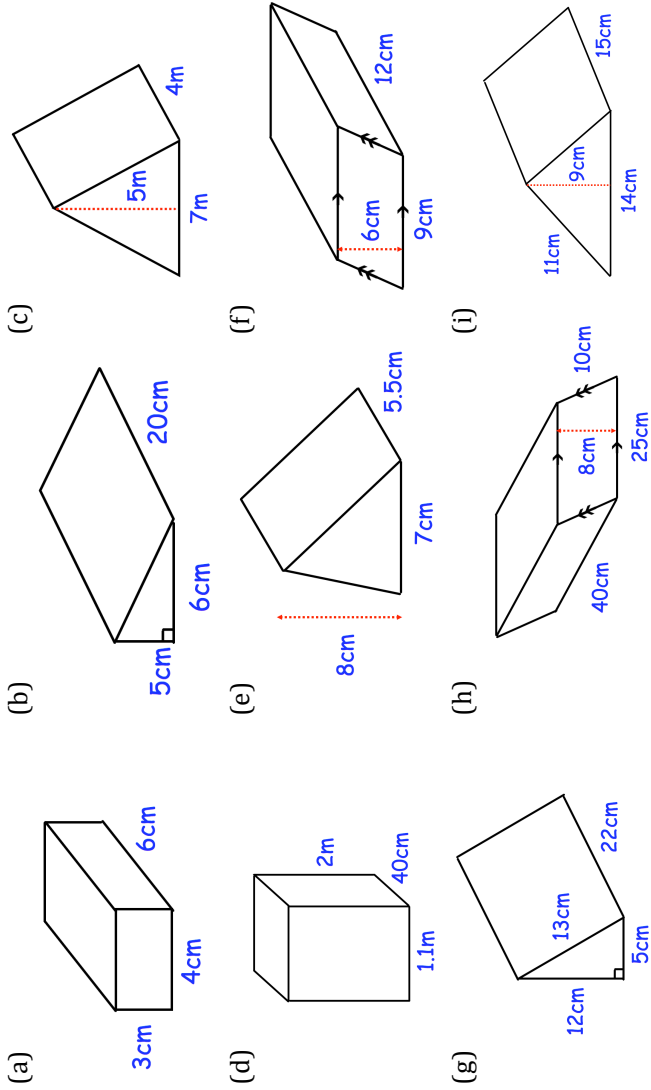

Question 2: Calculate the volume of each prism below

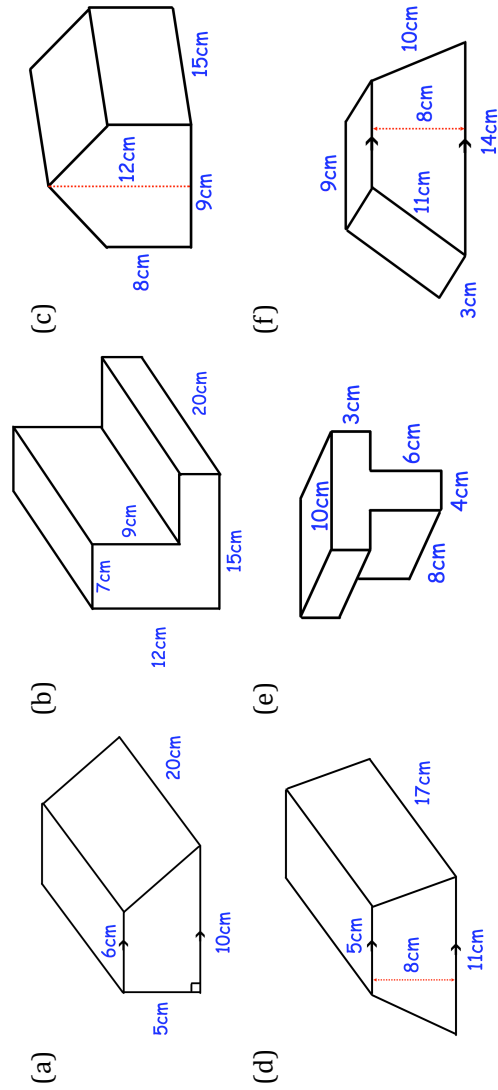

Question 3: Calculate the volume of each cylinder below

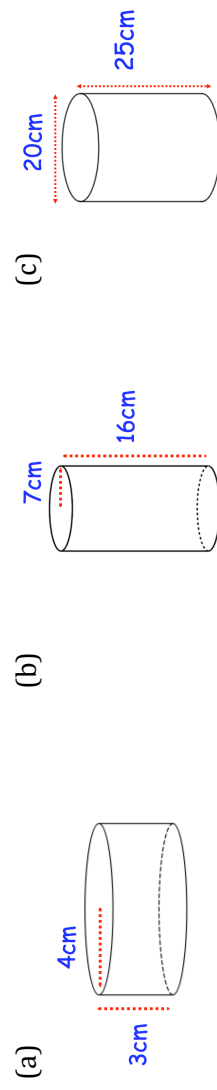

## Extension

Question 1: Cillian makes two cuboids out of clay.  
Both cuboids have the same volume.  
Find  $y$ .

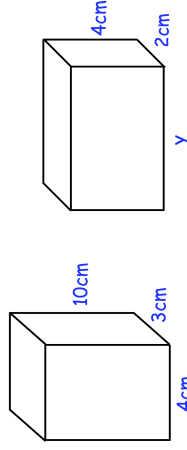

Question 2: The cuboid and the triangular prism have the same volume.  
Find  $x$ .

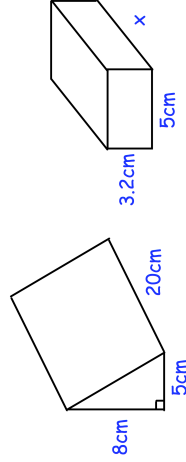

Question 3: Boxes of coffee are placed into a crate.  
Each box of coffee is a cuboid and the crate is also a cuboid.  
How many boxes of coffee fit into the crate?

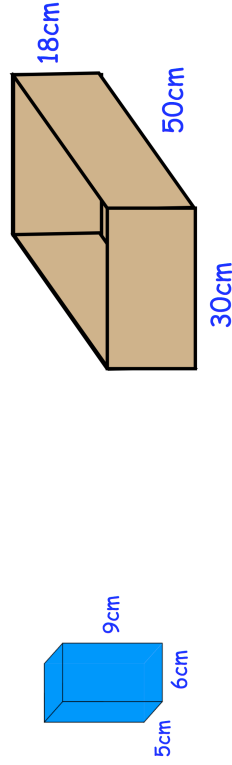

Question 4: James wants to fill an empty flowerpot with soil.  
He has 2 litres of soil.  
Given  $1 \text{ litre} = 1000\text{cm}^3$   
Does James have enough soil to fill the flowerpot?

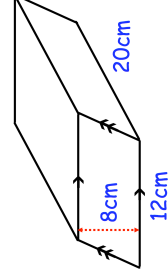

## Extension

- Question 5: The solid triangular prism shown below is made from metal. The prism is melted down and the metal is used to create a solid cube. Find the side length of the cube.

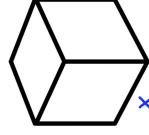
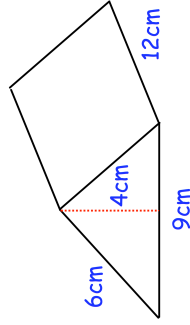

- Question 6: The swimming pool in a leisure centre is shown below. The length of the swimming pool is 25m and the width is 12m. The depth of the shallow end is 1m and the depth of the deep end is 2.4m. Given  $1\text{ m}^3 = 1000$  litres  
Work out how much water, in litres, the swimming pool holds.

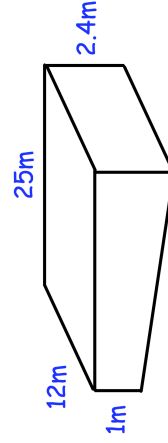

- Question 7: A fish tank is  $\frac{1}{4}$  full of water.  
Harry pours a 400ml glass of water into the fish tank.  
Given  $1\text{ ml} = 1\text{ cm}^3$   
What will the depth of the water of the fish tank then be?

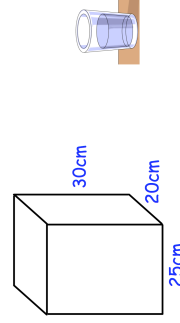

- Question 8: A solid glass paperweight is in the shape of a triangular prism. The density of the glass is  $2.4\text{ g/cm}^3$ .  
Work out the mass of the paperweight.

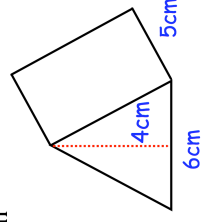

# Fluency Practice



## Volume of a Cuboid

Calculate the volume of these cuboids.

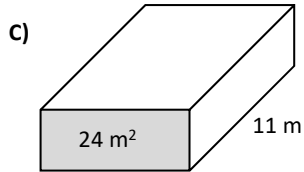
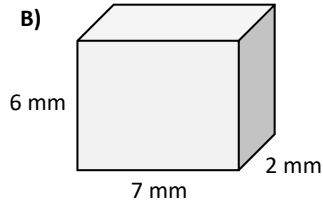
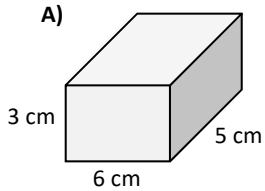

The area of the face of this prism is  $24 \text{ m}^2$ .

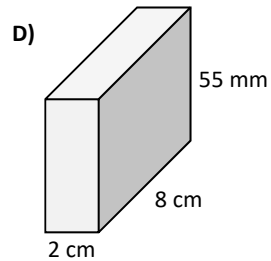

This is a cube.  
What is its volume?

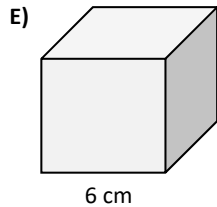

The volume of this cuboid is  $105 \text{ mm}^3$ .  
What is the cuboid's length?

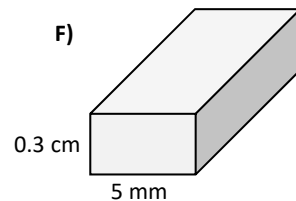

G) The volume of a cuboid is  $64 \text{ m}^3$ .  
Its height is twice its width.  
Its length is twice its height.  
What are the cuboid's dimensions?

Complete the table for cuboids A to E.

Cuboid	Width	Height	Length	Volume
A	5 cm	7 cm	5.5 cm	
B	6 cm	45 mm		$189 \text{ cm}^3$
C		6 m	450 cm	$94.5 \text{ m}^3$
D	8.5 mm		7 mm	$148.75 \text{ mm}^3$
E	2.4 cm	32 mm	0.067 m	

F) These are the side lengths of cubes. Calculate their volumes.  
G) These are the volumes of cubes. Calculate their side lengths.

- a) 8 cm  
b) 5 mm  
c) 3.5 m  
d) 0.5 cm

- a)  $64 \text{ cm}^3$   
b)  $125 \text{ m}^3$   
c)  $343 \text{ mm}^3$   
d)  $729 \text{ cm}^3$

I) These two attached cuboids are identical.

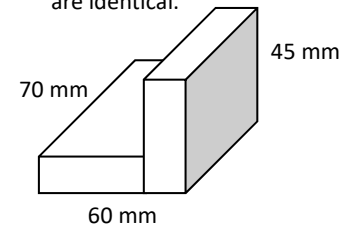

Calculate the volume of these 3 compound cuboids.

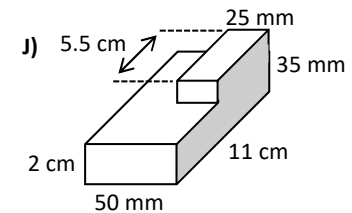
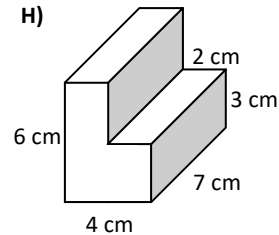

# Fluency Practice

## Volume of a Prism



= 1 cm<sup>3</sup>

The prism has been cut into two.

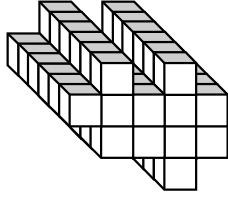
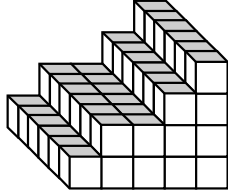
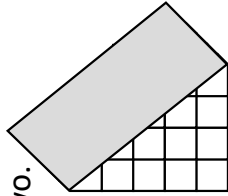
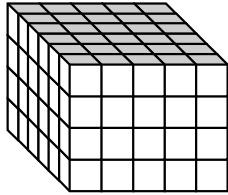

**A)** Volume =      cm<sup>3</sup>

**B)** V =

**C)** V =

**D)** V =

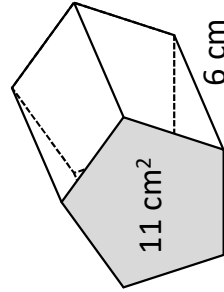

**E)** V =

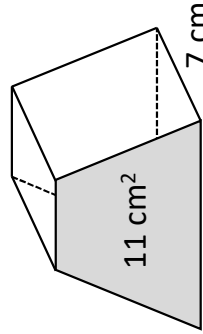

**F)** V =

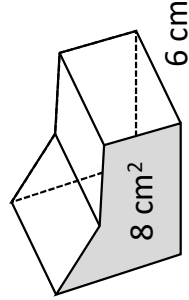

**G)** V =

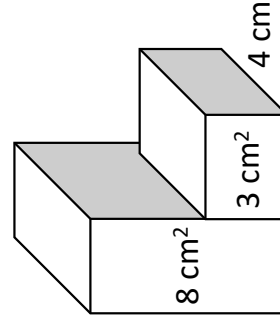

**H)** V =

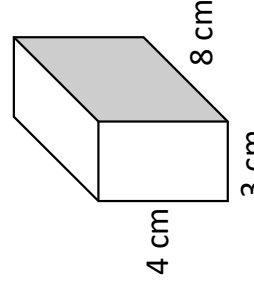

**I)** V =

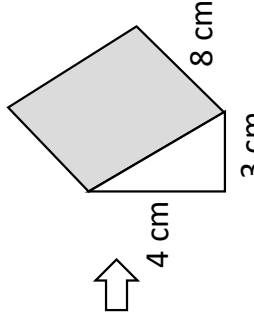

**J)** V =

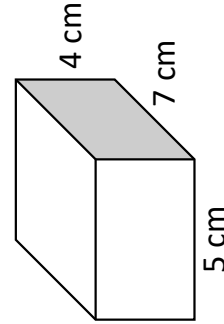

**K)** V =

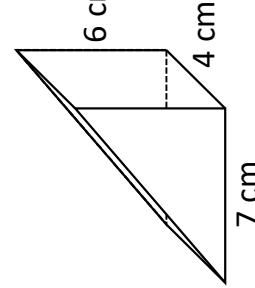

**L)** V =

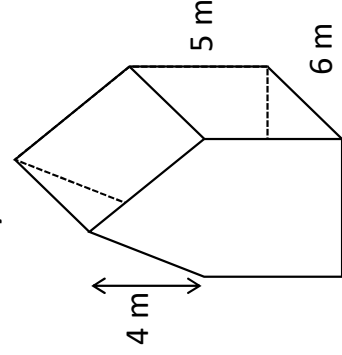

**M)** V =



## Extension

volume of a triangular prism

(1)

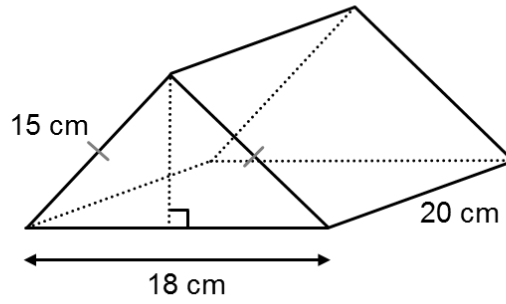

what is the volume?

(2)

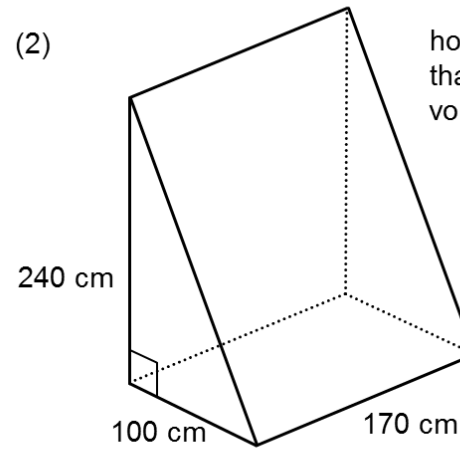

how much bigger  
than  $2 \text{ m}^3$  is the  
volume?

(3)

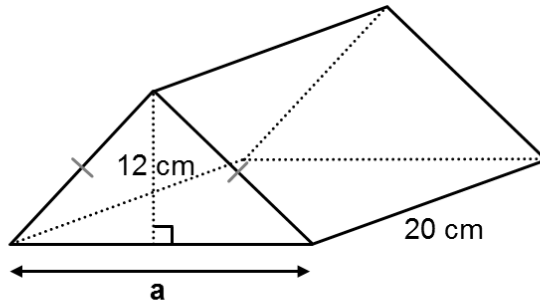

volume =  $1200 \text{ cm}^3$   
what is  $a$ ?

(4)

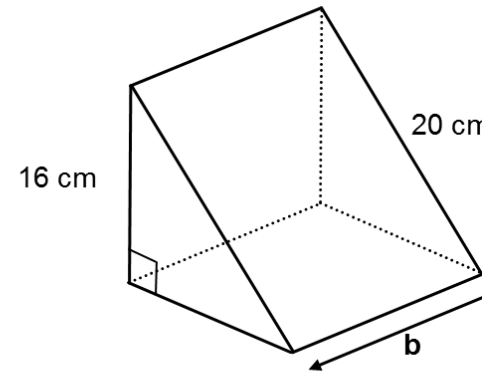

volume =  $960 \text{ cm}^3$   
what is  $b$ ?

# Extension

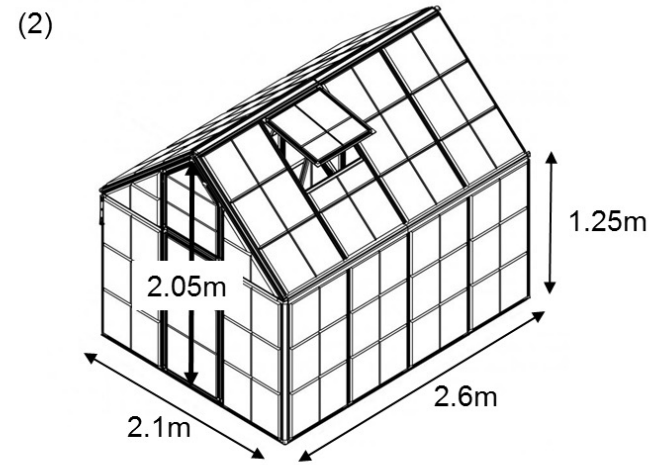
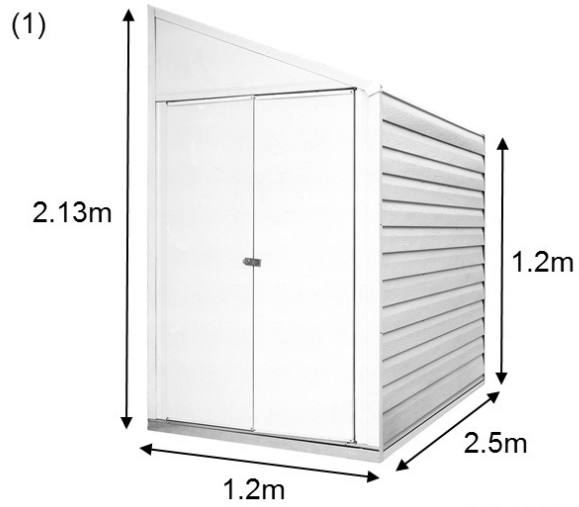

guess the volumes of the sheds to the nearest  $\text{m}^3$  and then work them out

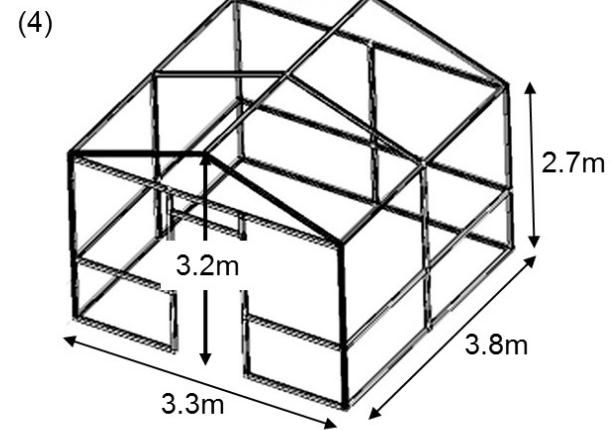
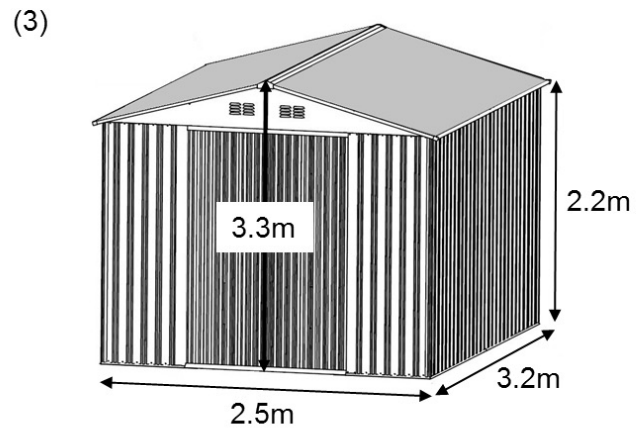

# Fluency Practice

Find the surface area of each of these cubes.

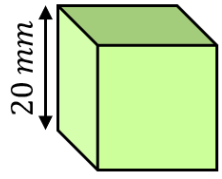

(b)  A green cube with a side length of 20 mm.

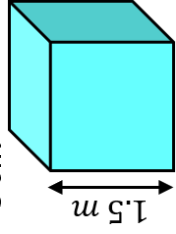

(c)

Find the surface area of each of these cuboids.

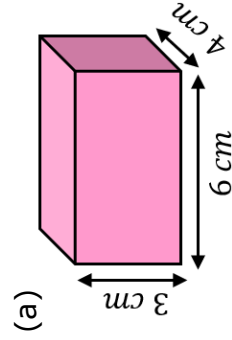

(a)

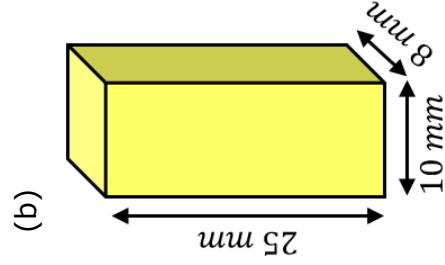

(b)

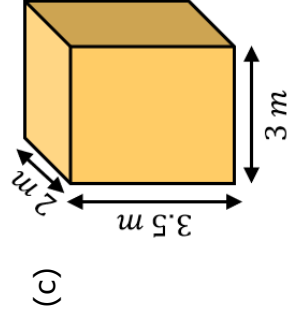

(c)

Find the surface area of these cuboids.

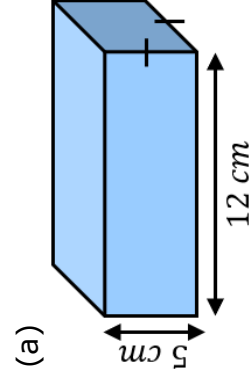

(a)

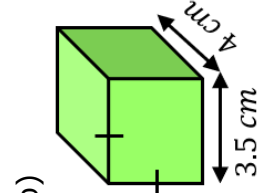

(b)

(a) A cube has a side length of  $x$  cm and a surface area of  $337.5 \text{ cm}^2$ . Find  $x$ .

(b) A cuboid has side lengths 5 cm, 8 cm and  $y$  cm. Its surface area is  $314 \text{ cm}^2$ . Find  $y$ .

# Fluency Practice

Question 1: Work out the surface area of each of the following cubes.

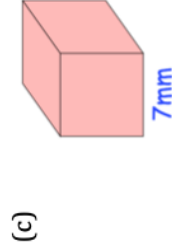
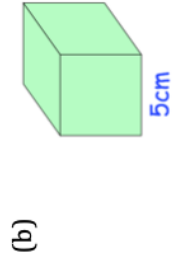
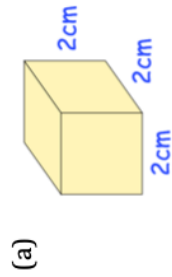

Question 2: Work out the surface area of each of the following cuboids.

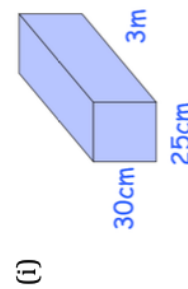
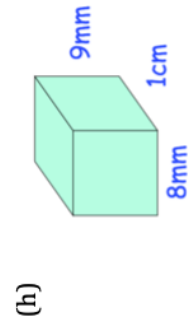
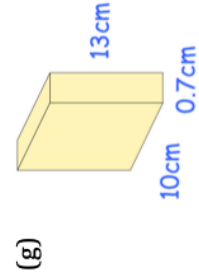
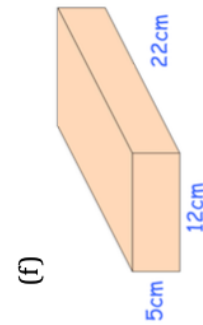
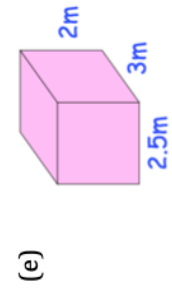
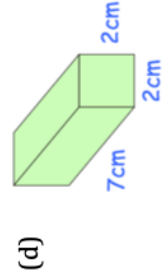
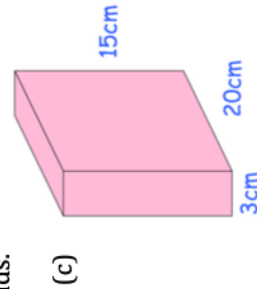
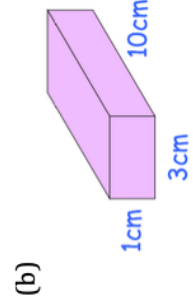
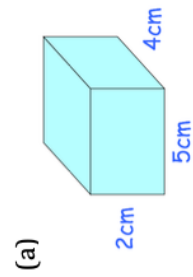

Question 3: Calculate the surface area of a cube with side length 12 cm

Question 4: Calculate the surface area of a cube with side length  $\frac{1}{2}$  cm

## Extension

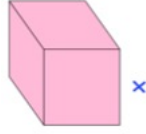

Question 1: A cube has a surface area of  $54\text{cm}^2$   
Find the side length,  $x$ , of the cube

Question 2: A company is designing a new box to hold coffee.  
They have 3 designs, cuboids A, B and C.

All 3 designs have the same volume of  $600\text{cm}^3$   
The company want to choose the design with the smallest surface area.  
Which cuboid should they choose?

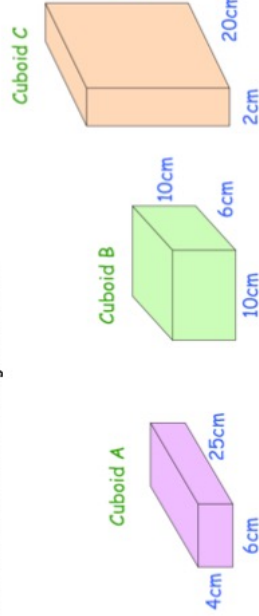

Question 3: A cube has a volume of  $1000\text{cm}^3$ .

Work out the surface area of the cube.

Question 4: Jamie is trying to work out the surface area of the cuboid below.  
Can you spot any mistakes?

$$9 \times 5 = 45$$

$$7 \times 5 = 35$$

$$9 \times 7 = 63$$

$$45 + 35 + 63 = 143\text{cm}^2$$

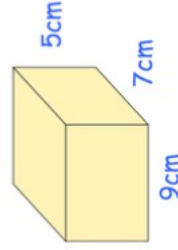

Question 5: Find  $y$  for each of the cuboids below

(a) Surface area =  $158\text{cm}^2$

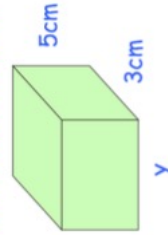

(b) Surface area =  $346\text{cm}^2$

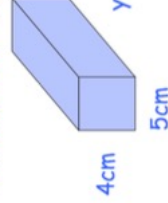

(c) Surface area =  $90\text{cm}^2$

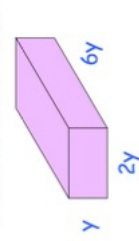

# Problem Solving

Diagrams not to scale!

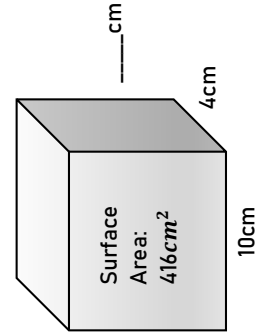
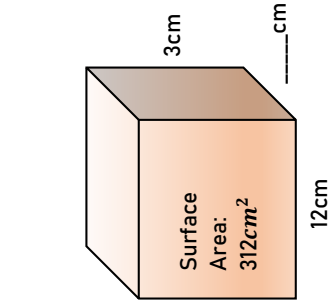
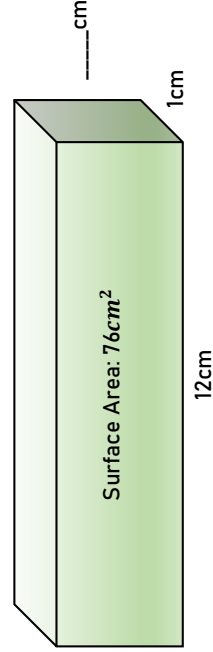
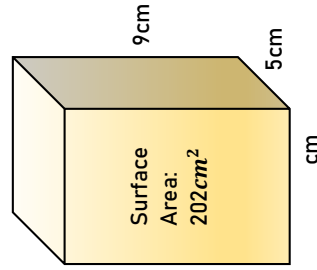
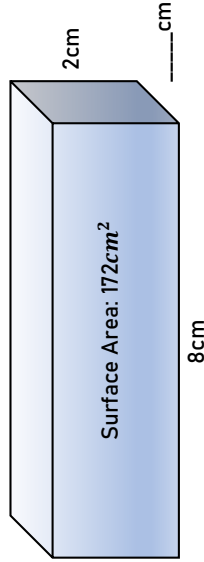
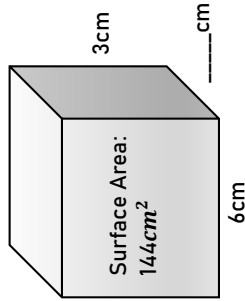
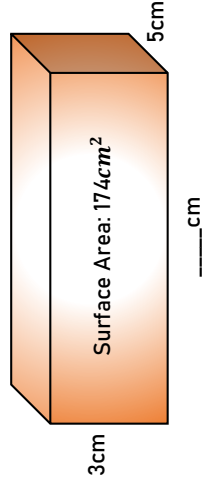
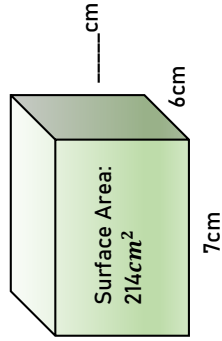
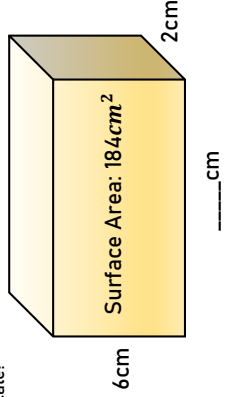
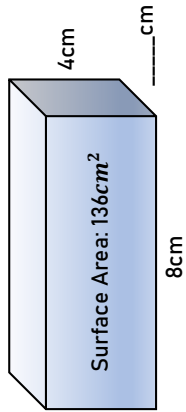

## Instructions

These are the missing lengths of each cuboid. Where should they go to give the required surface areas?

- 2 3 4 5 6  
 7 8 9 10 12

# Fluency Practice

**Q1** Calculate the surface area of the following prisms.

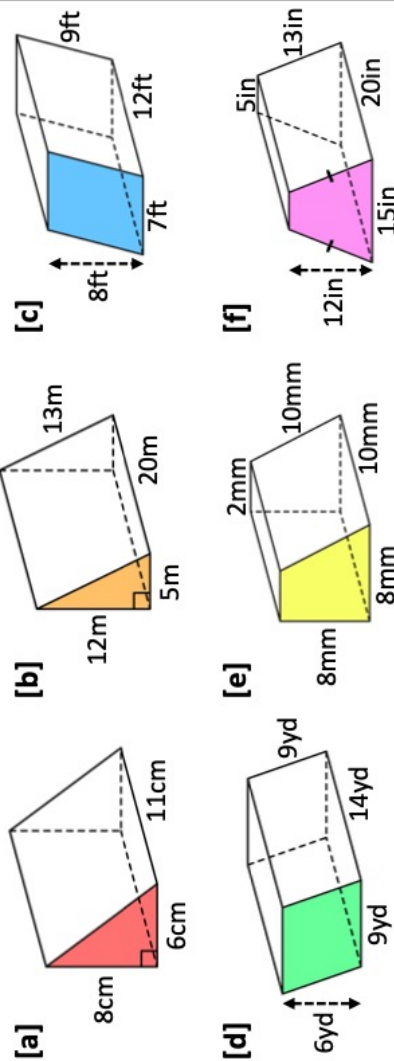

**Q2** Calculate the volume of the following L-shape prisms.

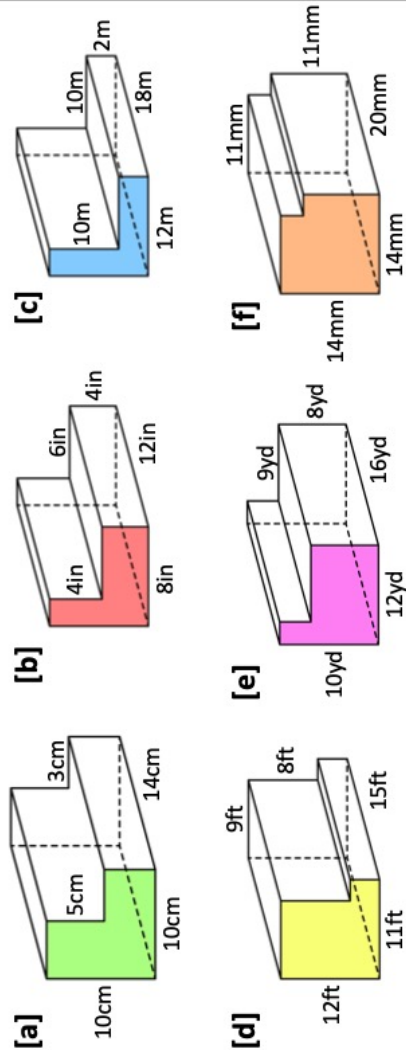

**Q3** Calculate the surface area of the following prisms.

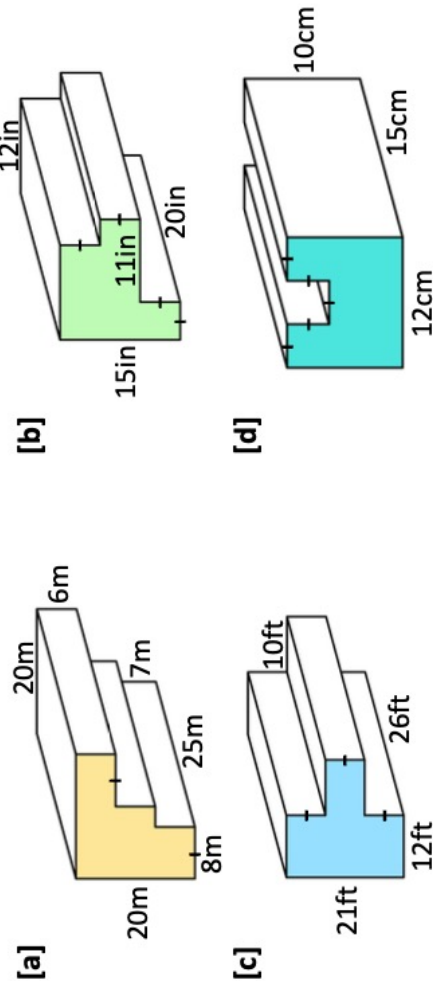

## Fluency Practice

**Q4** Each of the four shapes shown below is made from 6 unit cubes. Which has the smallest surface area?

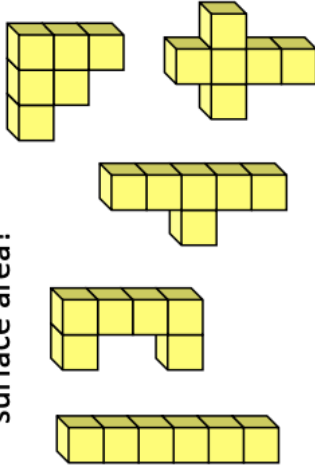

**Q5** A cube has a surface area of  $96\text{cm}^2$ . Find the side length of the cube.

**Q6** A cube has a surface area of  $294\text{cm}^2$ . Find the side length,  $x$ , of the cube.

**Q7** A cube has a surface area of  $150\text{cm}^2$ . Find the volume of the cube.

**Q8** Given that the surface area of the triangular prism below is  $96\text{cm}^2$ , find  $x$ .

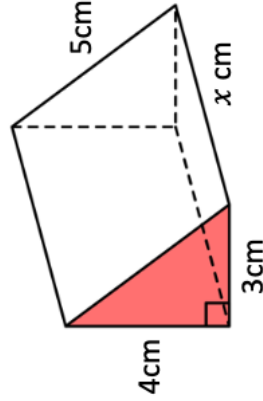

**Q9** Given that the surface area of the following prisms are equal, find  $y$ .

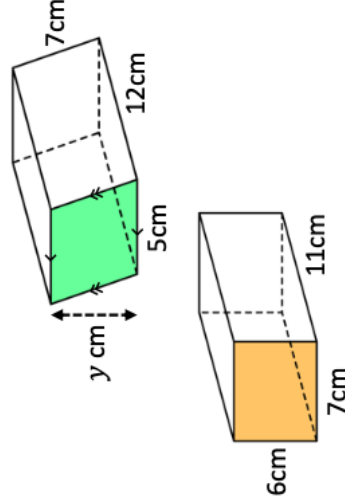

**Q10** Find an expression, in terms of  $x$ , for the surface area of the prism. Give your answer in its simplest form.

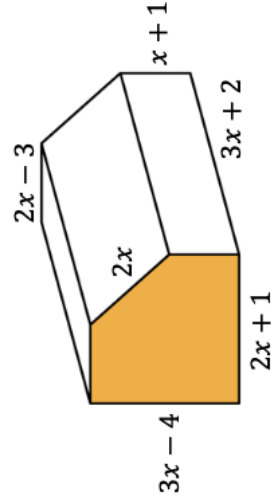

**Q11** Given that the surface area of the following L-shape prism is  $194\text{cm}^2$ , find the perimeter of its cross section. Give your answer in its simplest form.

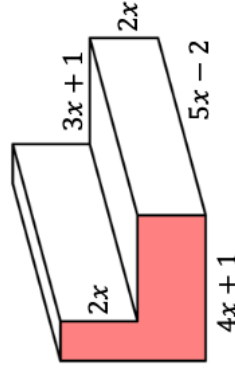



# Fluency Practice

Find the surface area of each of these triangular prisms.

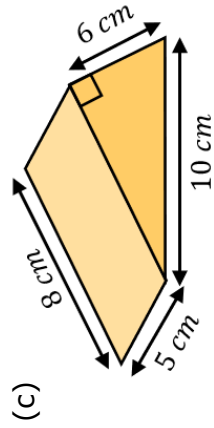
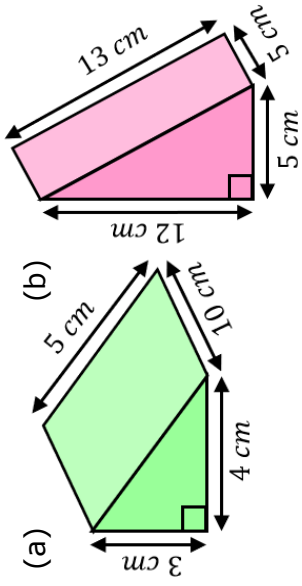

Find the surface area of each of these triangular prisms.

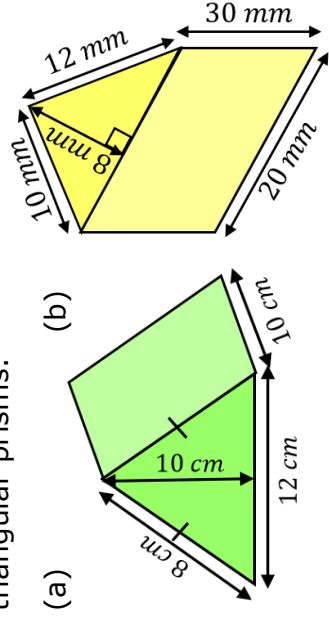

Find the surface areas of these trapezoidal prisms.

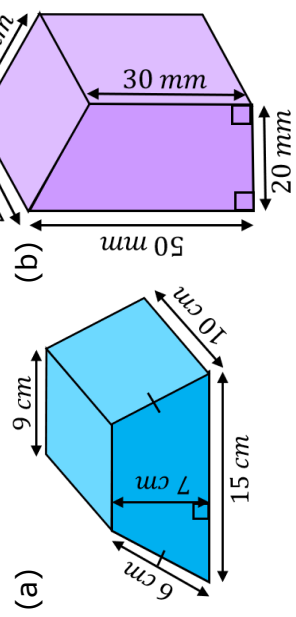

These two 3D shapes have the same surface area. Find the missing length.

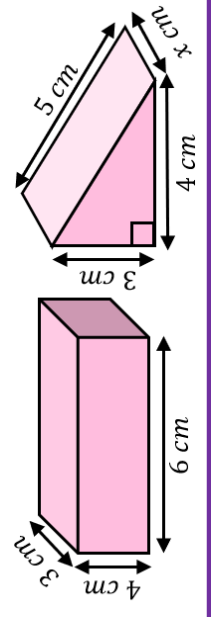

# Fluency Practice



## RAT Prisms

These solid shapes are prisms with a **Right-Angled Triangle** for a base.  
 Calculate the **surface area** of each shape.  
 (Begin by finding the missing length to 1 dp. Use that figure in your calculations.)

NOT DRAWN  
 ACCURATELY

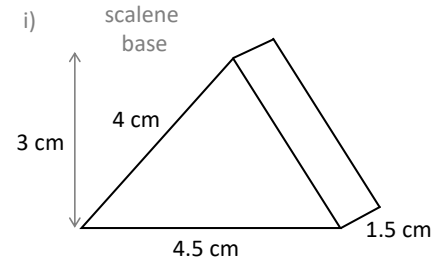
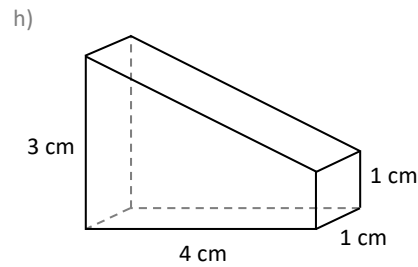
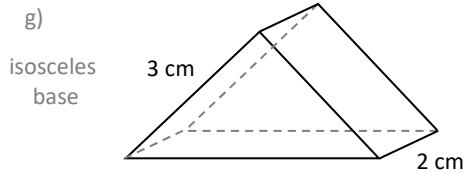
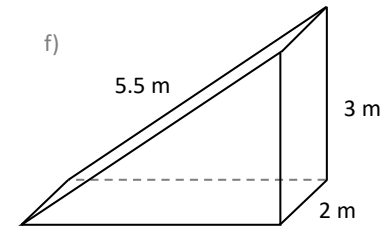
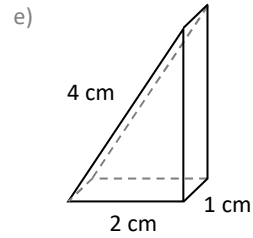
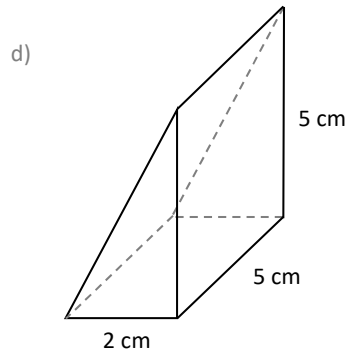
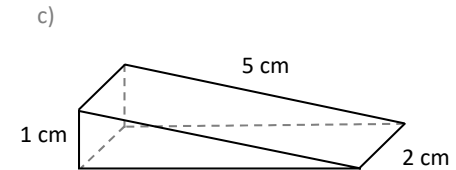
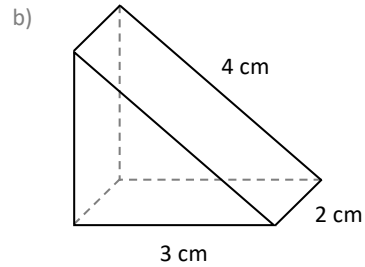
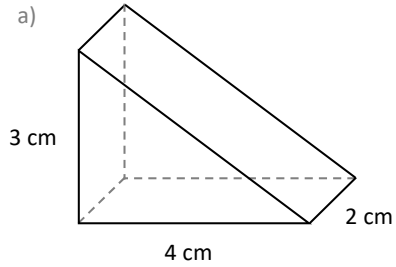

# Fluency Practice

Question 1: Work out the surface area of each of the prisms below.

(a)

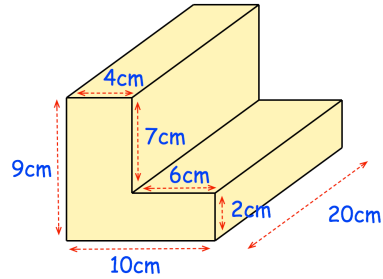

(b)

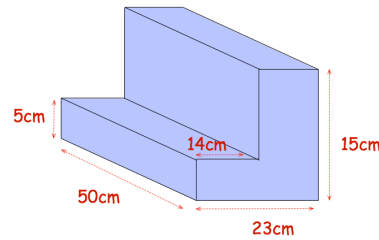

(c)

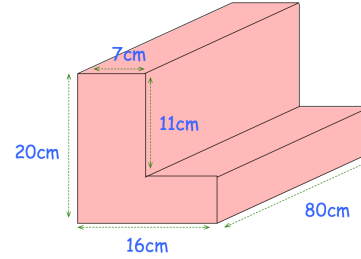

(d)

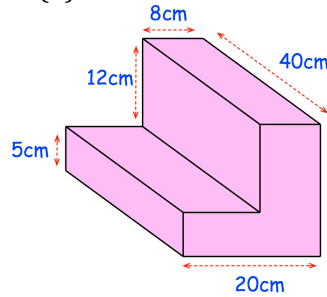

(e)

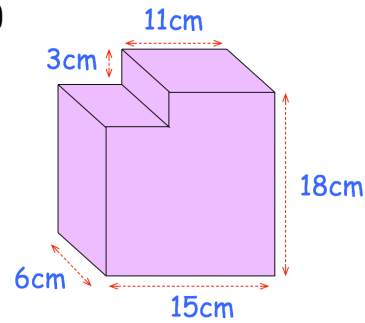

(f)

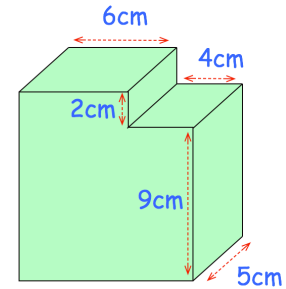

Question 1: Shown below is a prism.  
Find the surface area of the prism.  
Give your answer in  $\text{m}^2$ .

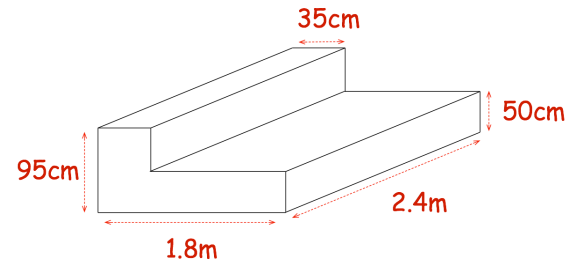

## Extension

surface area and volume of triangular prisms

(1)

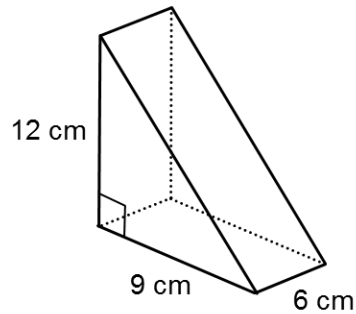

find the volume of the triangular prism

also find the surface area of the prism

make sure that you state the units

(2)

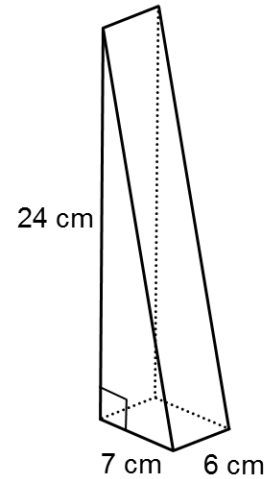

find the volume of the triangular prism

and find the surface area of the prism, stating the units

(3)

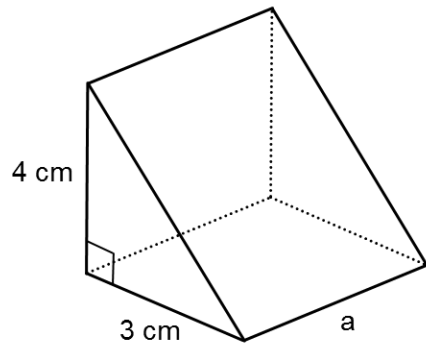

show that the surface area is always a multiple of 12

find a relationship between the surface area and the volume

(4)

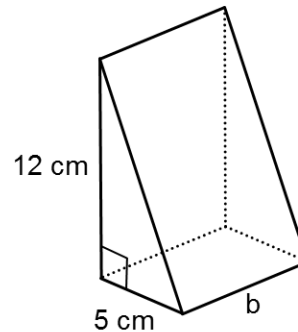

show that the surface area is always a multiple of 30

show that the surface area value is always a constant number more than the value for the volume

# Fluency Practice

Find the volume and surface area of each of these cubes or cuboids.

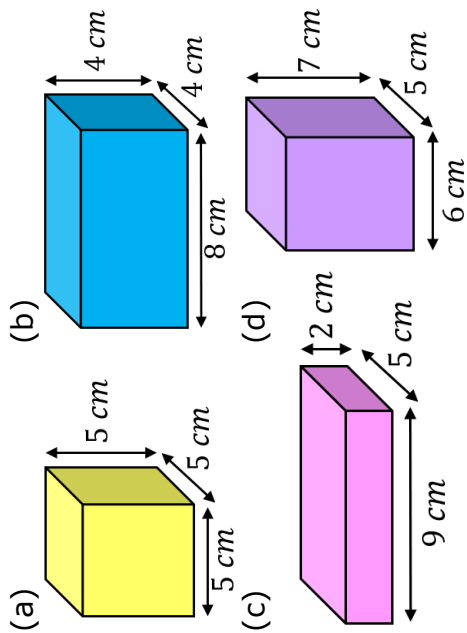

Find the volume and surface area of each of these cubes or cuboids.

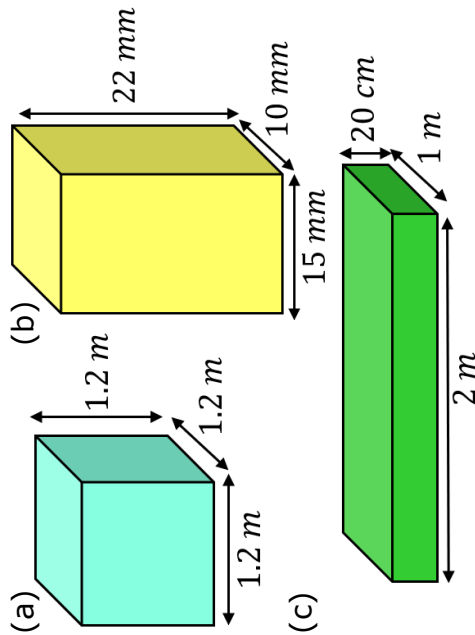

Find the missing lengths in these cubes and cuboids.

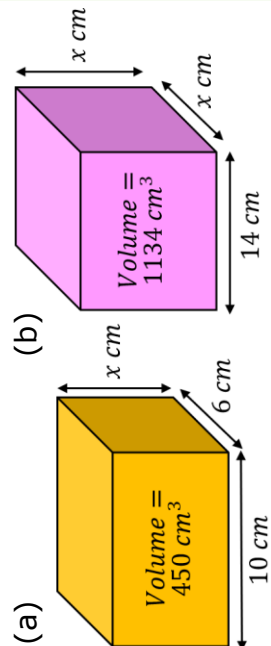

(a) A cube has a volume of  $5832\text{ cm}^3$ .

Find its side length.

(b) A cuboid with side lengths,  $x\text{ cm}$ ,  $5\text{ cm}$  and  $8\text{ cm}$  has a surface area of  $197\text{ cm}^2$ .

Find  $x$ .

## Fluency Practice

1. Work out the **volume** and **surface area** of each shape made of 1cm cubes:

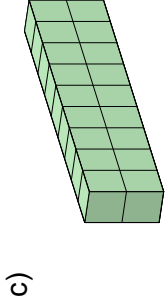
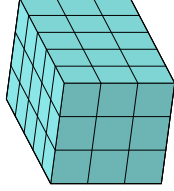
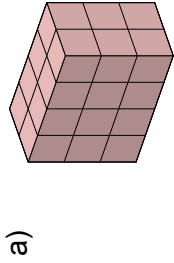

2. Work out the **volume** and **surface area** of each cuboid:

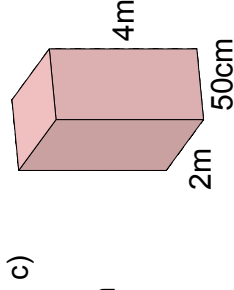
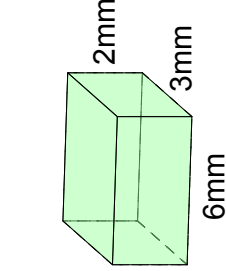
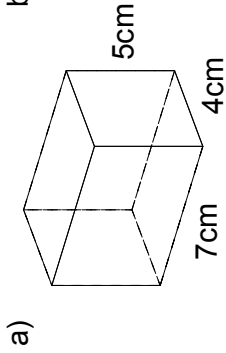

3. A cuboid has dimensions 0.8cm, 0.2cm and 6mm.  
Work out the volume and surface area of this cuboid.

4. a) Work out the side length of a cube with a volume of  $64\text{cm}^3$ .

- b) Work out the side length of a cube with a surface area of  $54\text{cm}^2$ .

5. John has two congruent cuboids as shown.

He joins the two cuboids together to make a larger cuboid by sticking together two identical faces.

Work out the largest possible surface area the larger cuboid could have.

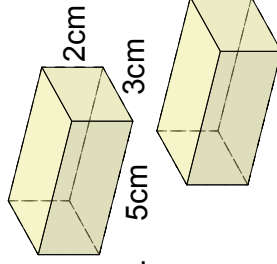

6. a) A cube has a side length of  $x$ .

Find expressions for the volume and surface area of this cube in terms of  $x$ .

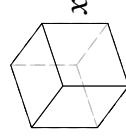

- b) A different cube has a side length of  $2y$ .

Find simplified expressions for the volume and surface area of this cube in terms of  $y$ .

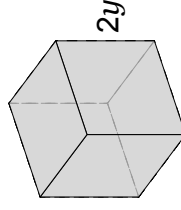

## Fluency Practice

7. The net of a cuboid is shown on a square grid, where each square has an area of  $1\text{cm}^2$ .

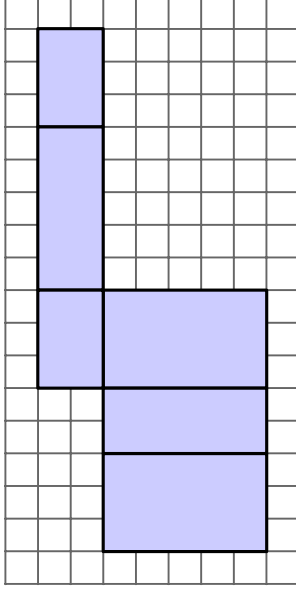

Work out the volume and surface area of this cuboid.

8. a) Work out the surface area of a cube with a volume of  $125\text{cm}^3$ .  
 b) Work out the volume of a cube with a surface area of  $600\text{cm}^2$ .
9. A cuboid has integer side lengths  $a$ ,  $b$  and  $c$ .  
 a) Robert says: 'The volume of the cuboid must be an even number.' Find an example to show that Robert is wrong.  
 b) Natalie says: 'The surface area of the cuboid must be an even number.' Prove that Natalie is correct.

10. A cuboid has a volume of  $36\text{cm}^3$ . The dimensions of the cuboid are all different integers. Work out all the possible sets of dimensions the cuboid could have.

11. A cuboid has side lengths  $p$  cm,  $q$  cm and  $r$  cm, where  $p$ ,  $q$  and  $r$  are all prime numbers.  
 Which of the following are possible volumes of the cuboid?

- a)  $15\text{cm}^3$     b)  $17\text{cm}^3$     c)  $24\text{cm}^3$     d)  $27\text{cm}^3$     e)  $30\text{cm}^3$

12. A cuboid has dimensions 2cm, 4cm and 6cm.

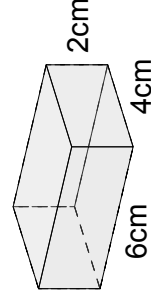

One of the dimensions is to be increased by 1cm.  
 Another of the dimensions is to be reduced by 1cm.

Work out the smallest and largest possible volumes of the resulting cuboid.

13. Two cubes have side lengths of  $x$  and  $x+1$  as shown.

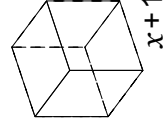
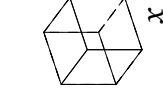

Show that the difference between their volumes is given by:  $3x^2 + 3x + 1$ .

# Fluency Practice

Calculate the volume and surface area of each cuboid:

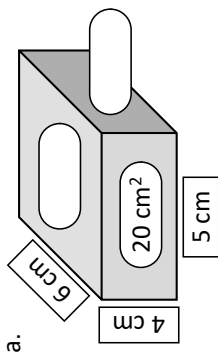

V:  SA:

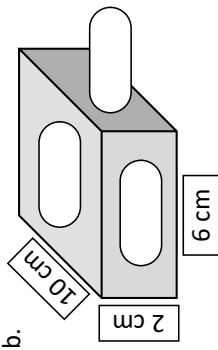

V:  SA:

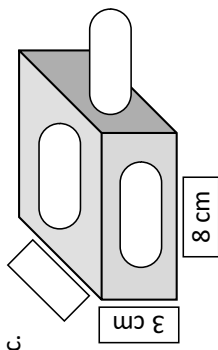

V:  SA:

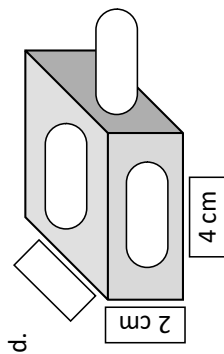

V:  SA:

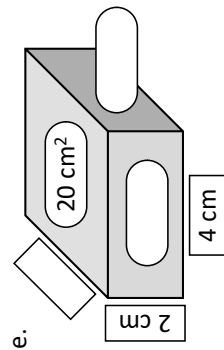

V:  SA:

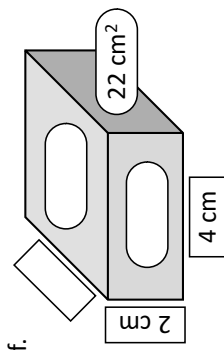

V:  SA:

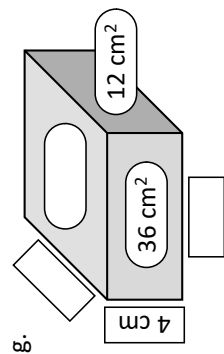

V:  SA:

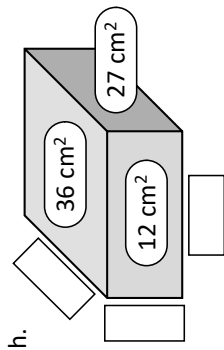

V:  SA:

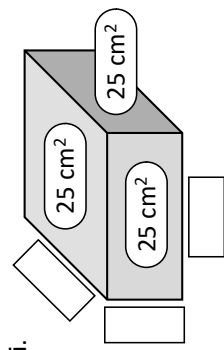

V:  SA:

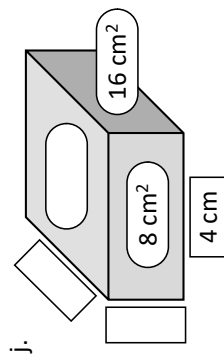

V:  SA:

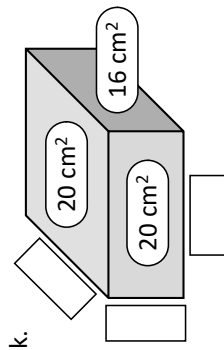

V:  SA:

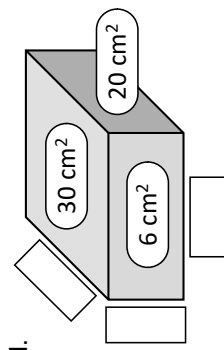

V:  SA:

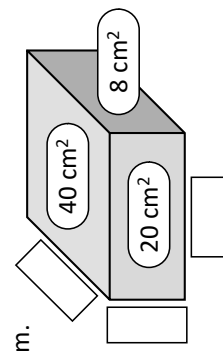

V:  SA:

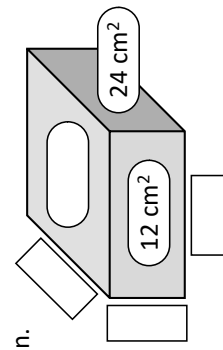

V:  SA:

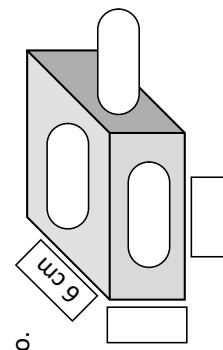

V:  SA:



## Completion Table

# Volume and Surface Area of a Cuboid

	A	B	C	Volume	Surface Area
a.	1 cm	2 cm	10 cm		
b.	1 cm	2 cm		10 cm <sup>3</sup>	
c.	1 cm	2 cm			10 cm <sup>2</sup>
d.	2 cm	5 cm	90 cm		
e.	2 cm	5 cm		90 cm <sup>3</sup>	
f.	2 cm	5 cm			90 cm <sup>2</sup>
g.	4 cm			400 cm <sup>3</sup>	400 cm <sup>2</sup>
h.	4 cm			288 cm <sup>3</sup>	288 cm <sup>2</sup>
i.	5 cm			250 cm <sup>3</sup>	250 cm <sup>2</sup>

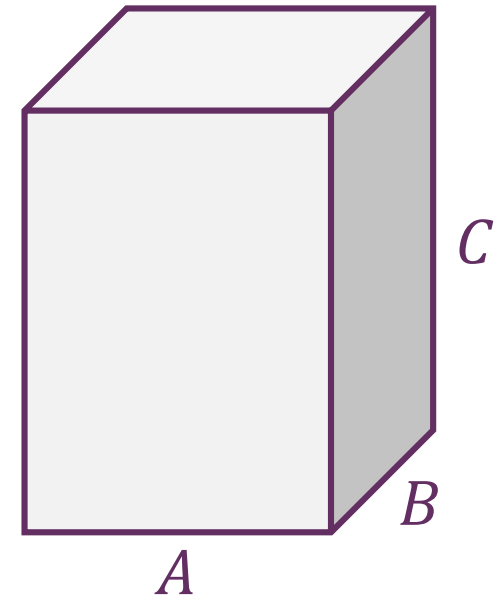

## Completion Table

### Volume and Surface Area of a Cuboid with...

	A	B	C	Volume	Surface Area
a.	$\frac{1}{2}$	$\frac{1}{2}$	$\frac{1}{4}$		
b.	$\frac{1}{2}$	$\frac{1}{3}$	$\frac{1}{4}$		
c.	$\frac{1}{2}$	$\frac{1}{4}$	$\frac{2}{5}$		
d.	$\frac{1}{2}$	$\frac{1}{5}$		$\frac{3}{70}$	
e.	$\frac{1}{2}$	$\frac{1}{6}$			1
f.	$\frac{1}{2}$	$\frac{1}{7}$	3		
g.	$\frac{1}{2}$	$\frac{1}{8}$	$1\frac{1}{2}$		
h.	$\frac{1}{2}$	$\frac{1}{9}$		1	

## Fractions

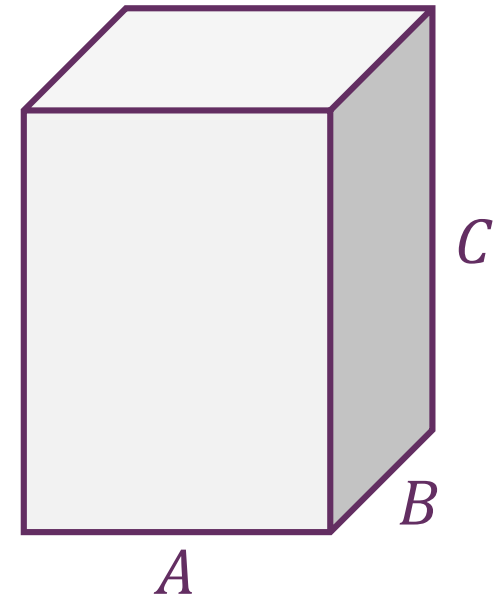

## Completion Table

### Volume and Surface Area of a Cuboid with...

	A	B	C	Volume	Surface Area
a.	0.25 cm	0.4 cm	10 cm		
b.	0.25 cm	0.6 cm	1 cm		
c.	0.5 cm	0.2 cm	2 cm		
d.	1.6 cm	0.5 cm		4 cm <sup>3</sup>	
e.	1.5 cm	1 cm			5 cm <sup>2</sup>
f.	0.75 cm	0.8 cm		6 cm <sup>3</sup>	
g.	1.4 cm	2.5 cm		7 cm <sup>3</sup>	
h.	0.5 cm	2 cm			8 cm <sup>2</sup>
i.	1.2 cm	1.5 cm			9 cm <sup>2</sup>

## Decimals

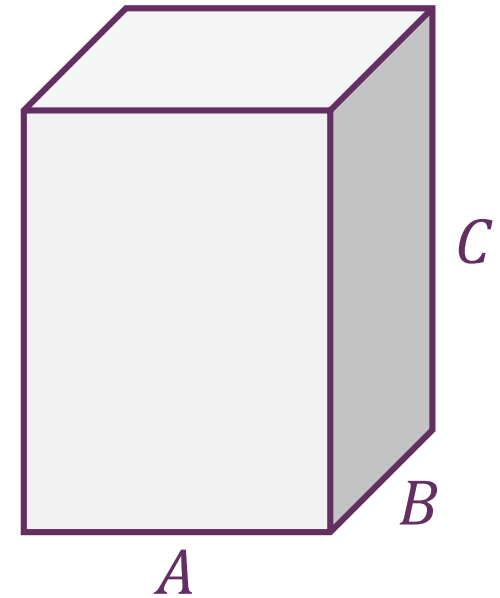

## Completion Table

Volume and Surface Area of a Cuboid with...

# Laws of Indices

	A	B	C	Volume	Surface Area
a.	$x$	$x$	$x$		
b.	$x^2$	$x^2$	$x^2$		
c.	$x$	$x$	$x^2$		
d.	$x$	$x^2$	$x^2$		
e.	$6^{11}$	$6^{11}$	$6^{11}$		
f.	$2^5$	$2^6$	$2^6$		
g.	$4^{32}$	$4^{34}$	$4^{34}$		
h.	$10^{10}$	$10^{11}$	$10^{12}$		

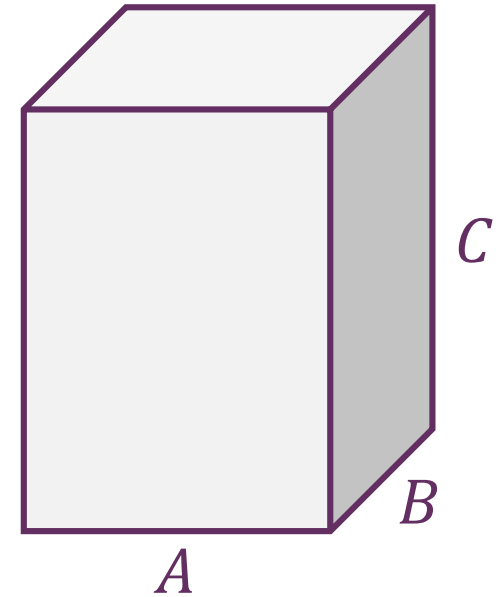

## Purposeful Practice

### Kellogg's Corn Flakes Investigation



*Which size is the most eco-friendly?*

*Which size gives the best value, and by how much?*

Kellogg's Corn Flakes come in various sizes of box. The main ones are listed below. Use the measurements given for each type to calculate the volume and surface area.

Box Size	Weight (g)	Cost	Height	Width	Depth	Volume	Surface Area
Small	250	£1.39	25cm	19cm	5.5cm		
Medium	500	£1.98	29.5cm	23cm	7cm		
Large	750	£2.68	35cm	24.5cm	9cm		

Remember:

- To calculate volume, multiply all 3 dimensions together.
- To calculate surface area, find the area of all 6 faces and add them together.

1. How much cardboard per gram of cornflakes does the most efficient box use?
2. Which box gives the best value (most cornflakes for your money)?
3. If you planned to make a 1500g box of cereal by doubling *one* of the dimensions of the 750g box, which dimension would you double to minimise the surface area, and what would the resulting surface area of the box be?

Extension: If you could choose the dimensions of your 1500g box, how would you minimise surface area? If you could choose *any* shape whatsoever, what would be best?

# Maths Venns

Volume =  $30\text{cm}^3$

Length, width  
and height  $\leq 4$

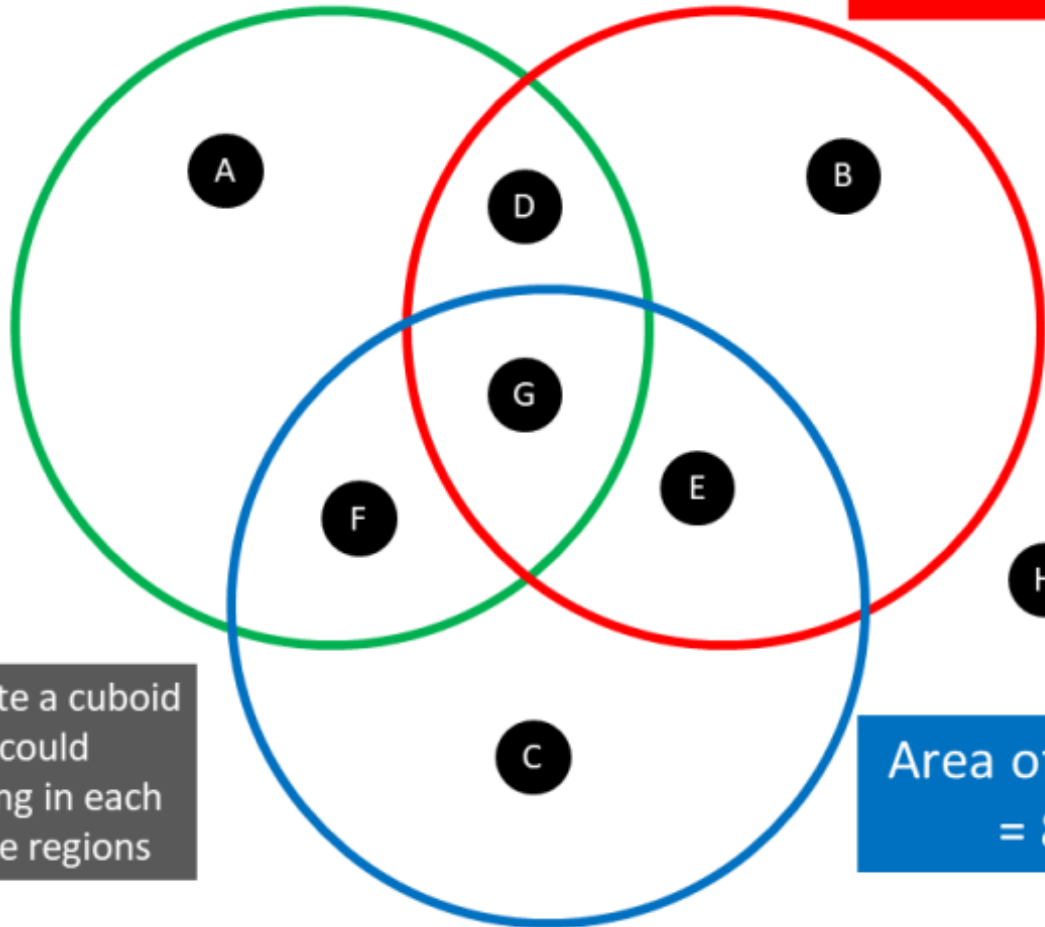

If you think a region is impossible to fill, convince me why!

Create a cuboid that could belong in each of the regions

Area of one face =  $8\text{cm}^2$

# Maths Venns

Volume =  $70\text{cm}^3$

Length, width and height  $\leq 4$

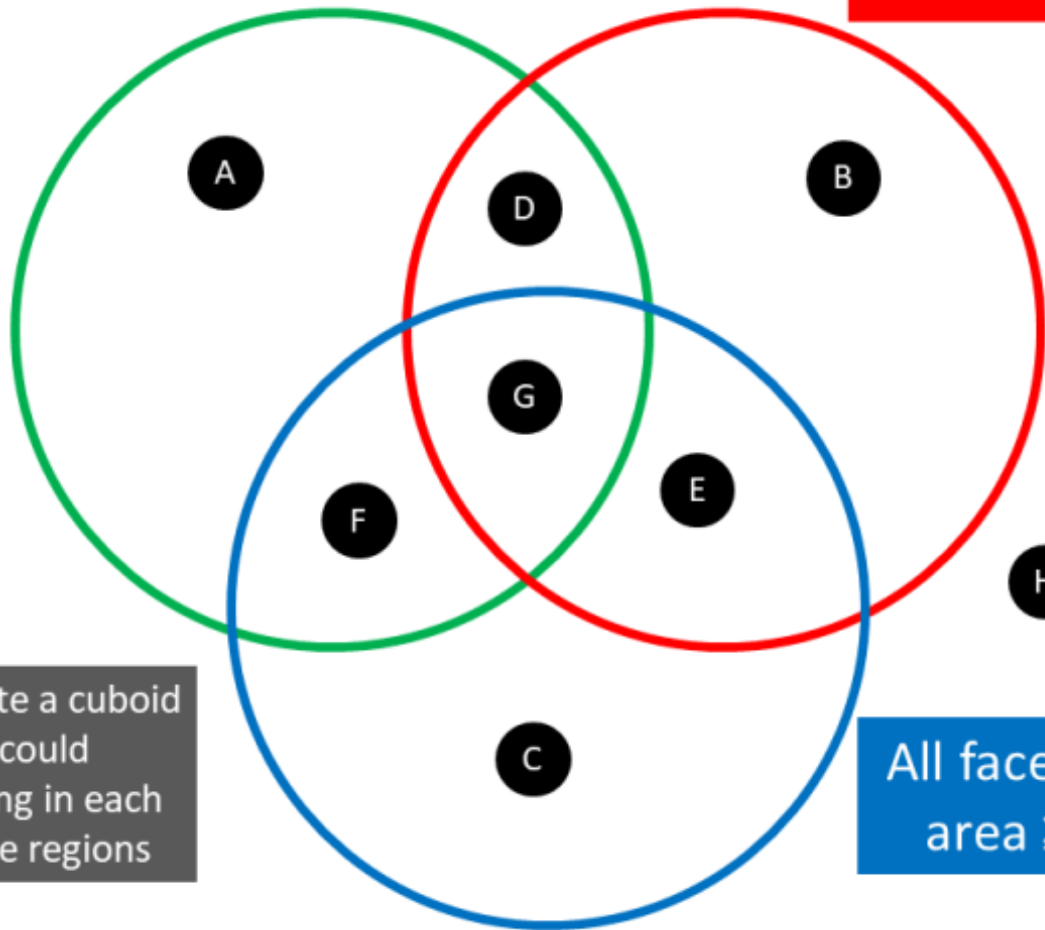

If you think a region is impossible to fill, convince me why!

Create a cuboid that could belong in each of the regions

All faces have an area  $\geq 10\text{cm}^2$

# Maths Venns

Volume  $< 50\text{cm}^3$

Surface Area  $> 60\text{cm}^2$

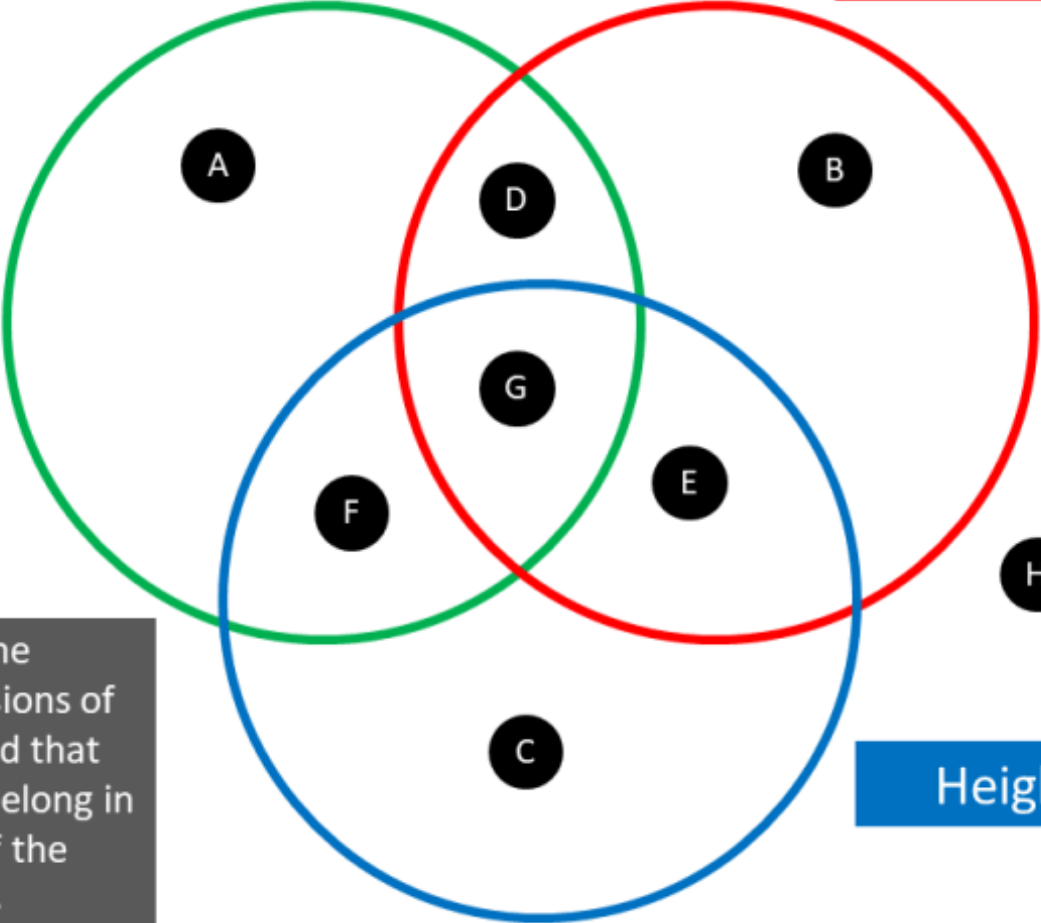

If you think a region is impossible to fill, convince me why!

State the dimensions of a cuboid that could belong in each of the regions

Height = 6cm



# Fluency Practice

Find the volume and surface area of each of these prisms.

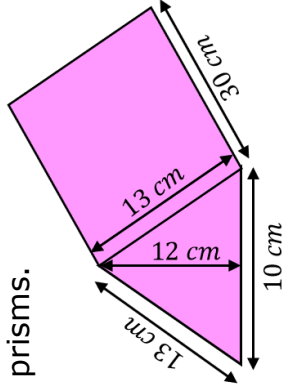

(a)

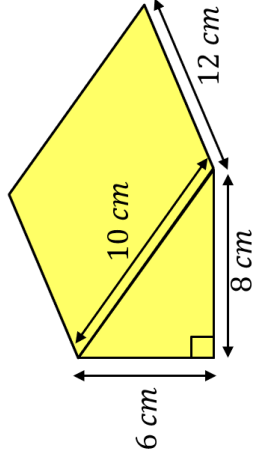

(b)

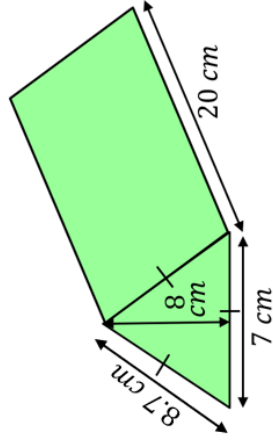

(c)

Find the volume and surface area of these prisms.

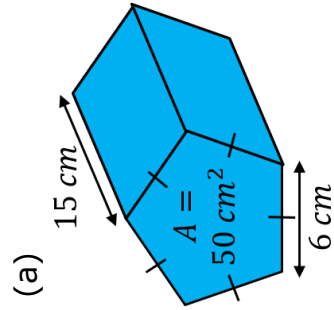

(a)

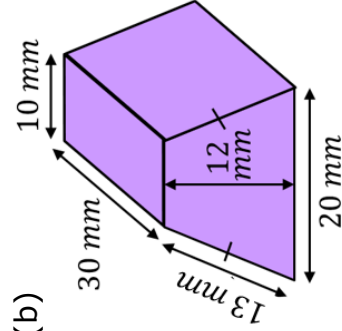

(b)

Find the missing lengths.

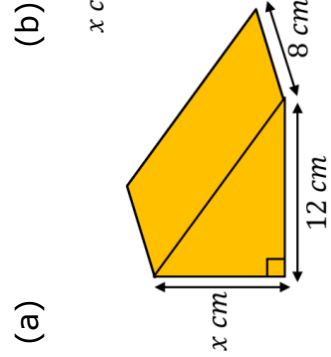

(a)

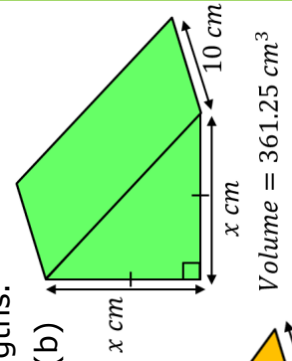

(b)

$$\text{Volume} = 361.25 \text{ cm}^3$$

$$\text{Volume} = 432 \text{ cm}^3$$

# Fluency Practice

1. Work out the **volume** and **surface area** of each prism made of 1cm cubes:

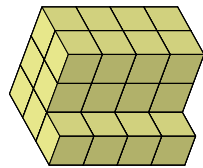

b)

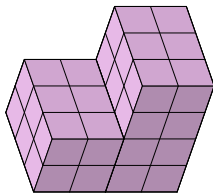

c)

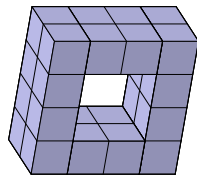

2. Work out the **volume** and **surface area** of each prism:

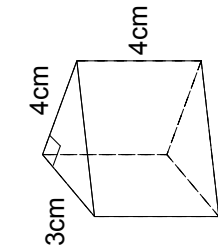

a)

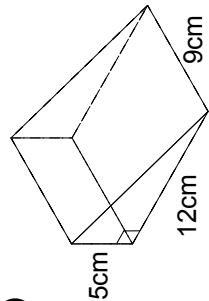

b)

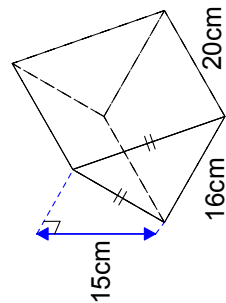

c)

3. Work out the volume of each of these prisms:

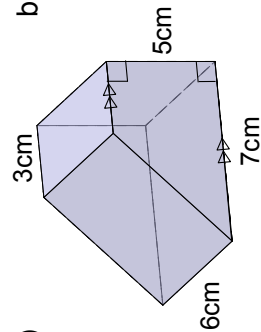

a)

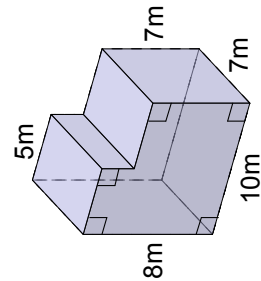

b)

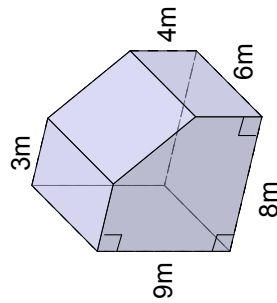

c)

4. Each of these prisms has a volume of  $60\text{cm}^2$ . Work out  $p$ ,  $q$  and  $r$ .

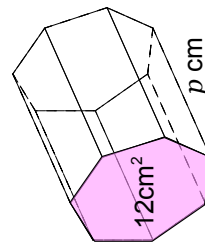

a)

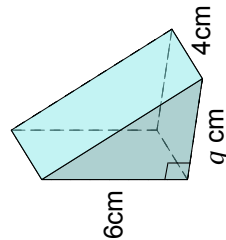

b)

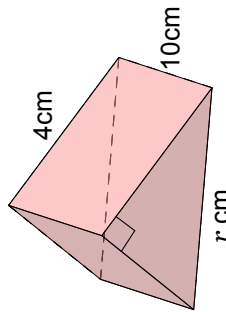

c)

# Fluency Practice

**Q1** Work out the volume of each of the following cylinders:  
 [i] in terms of  $\pi$ , [ii] to 3sf.

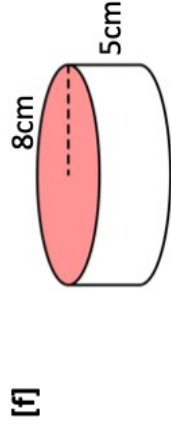
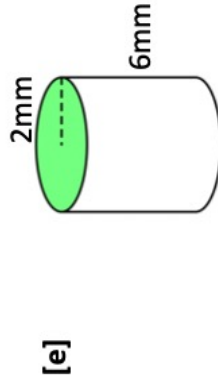
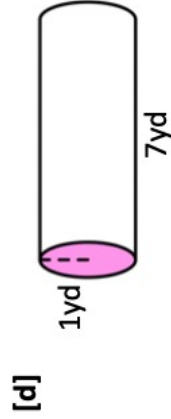
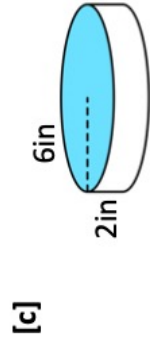
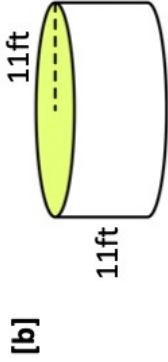
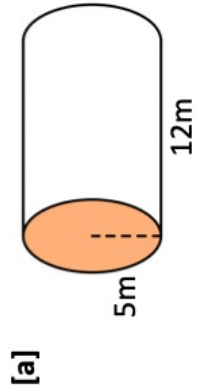

**Q2** Work out the volume of each of the following cylinders:  
 [i] in terms of  $\pi$ , [ii] to 3sf.

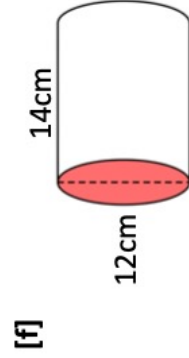
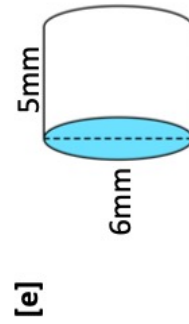
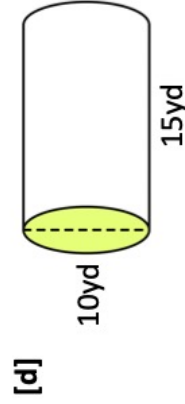
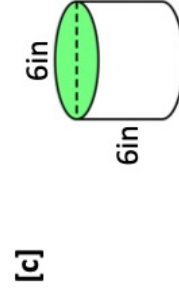
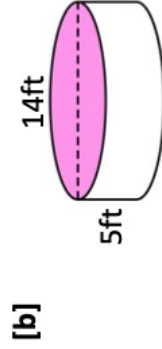
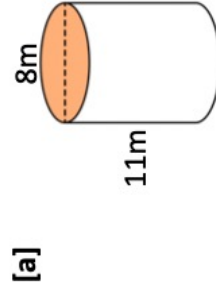

# Intelligent Practice

Calculate the volume. Give your answers in terms of  $\pi$  and to 1 decimal place.

Question 1

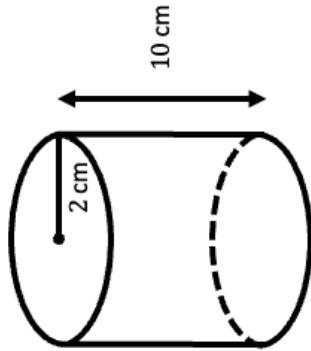

Question 2

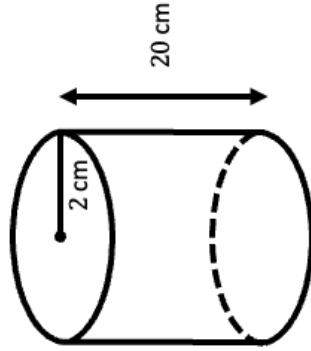

Question 3

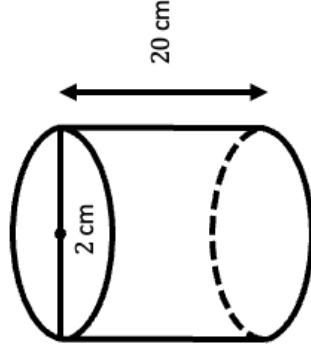

Question 4

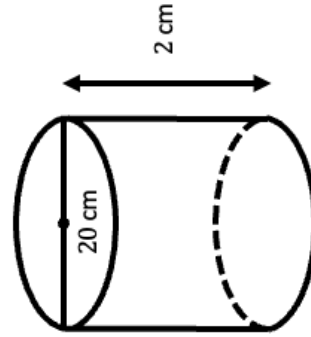

Question 5

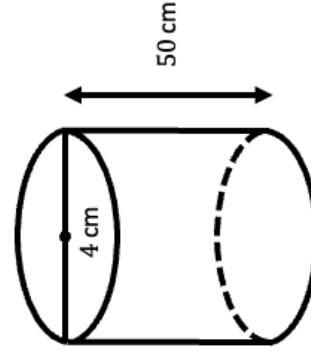

Question 6

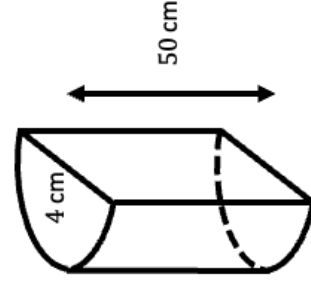

Question 7

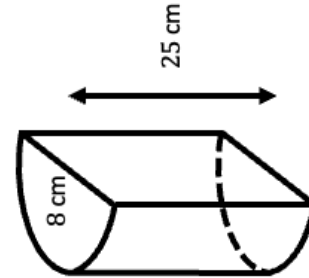

Question 8

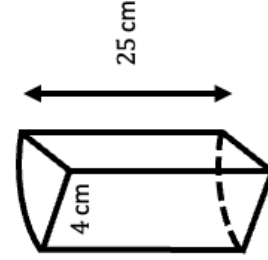

Question 9

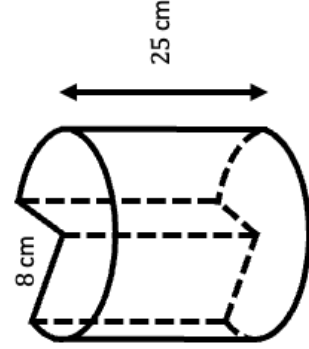

## Fluency Practice

**Q3** Work out the height of each cylinder.  
Give your answer to one decimal place.

**[a]**

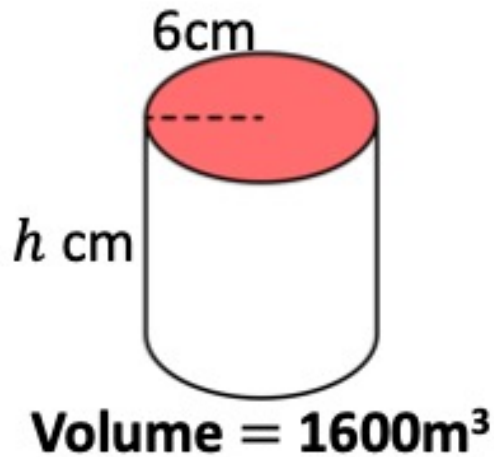

**[b]**

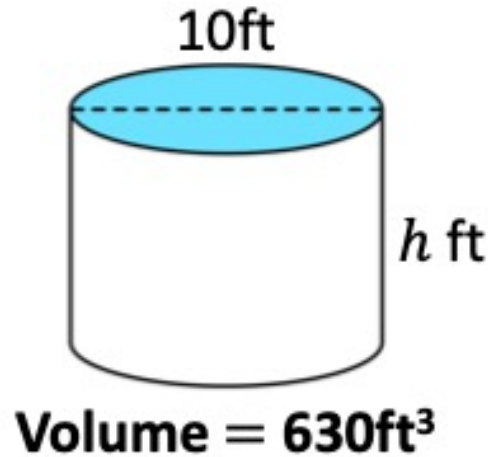

**[c]**

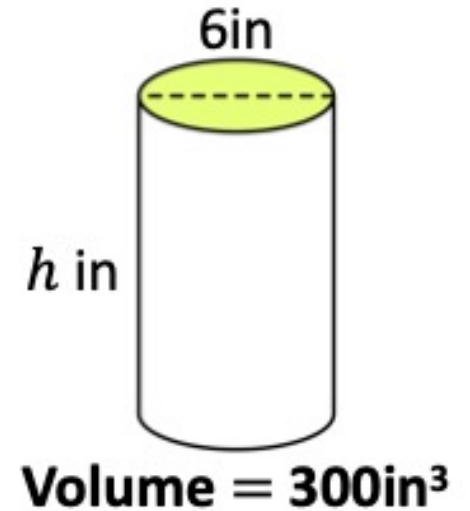

## Fluency Practice

**Q4** Work out the radius of each cylinder.  
Give your answer to one decimal place.

[a]

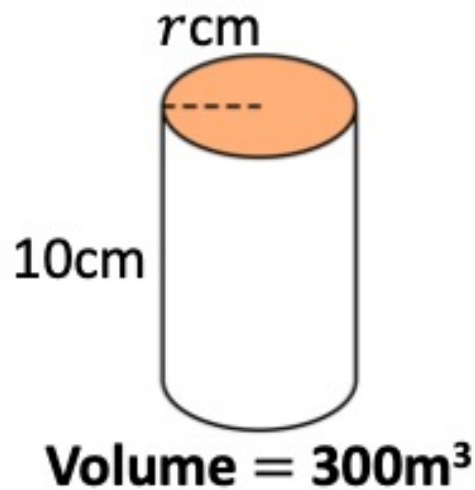

[b]

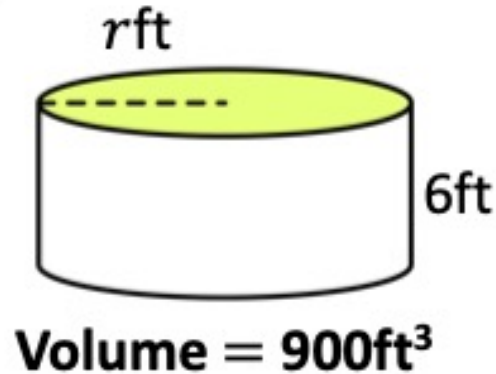

[c]

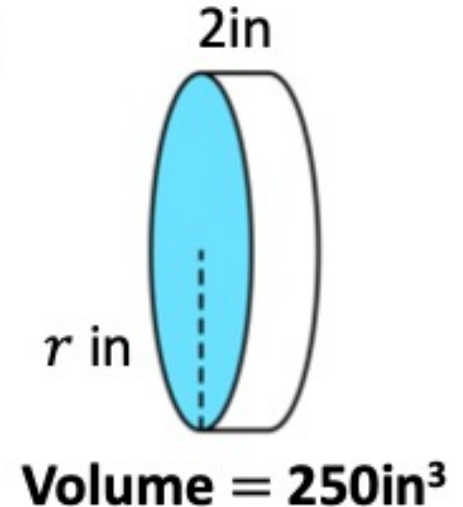

# Intelligent Practice

Find  $x$  given the volume. Give your answers to 1 decimal place if required.

**Question 1**

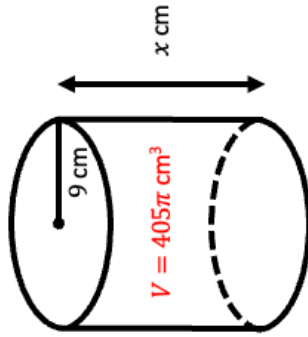

**Question 2**

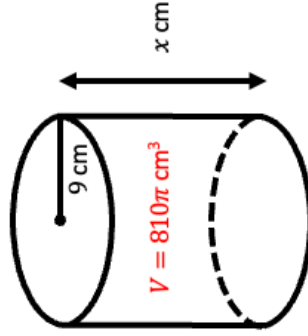

**Question 3**

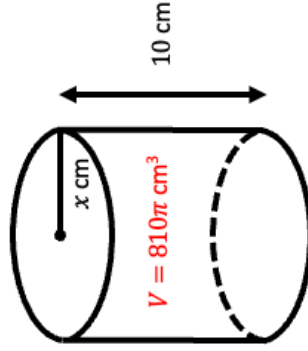

**Question 4**

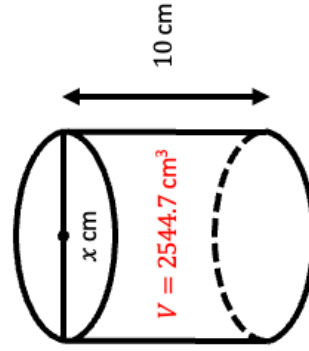

**Question 5**

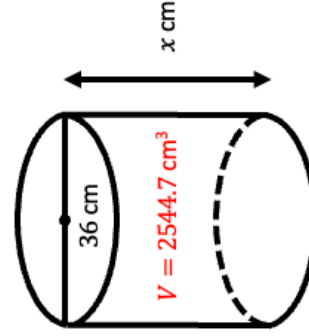

**Question 6**

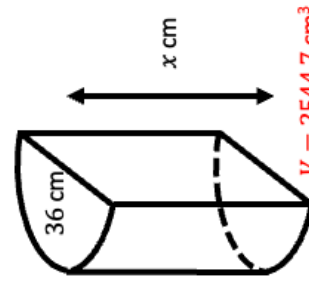

**Question 7**

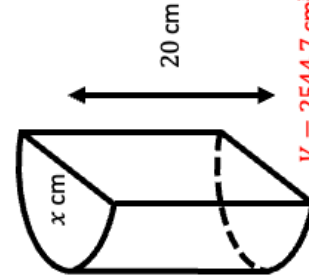

**Question 8**

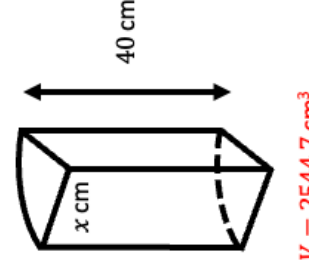

**Question 9**

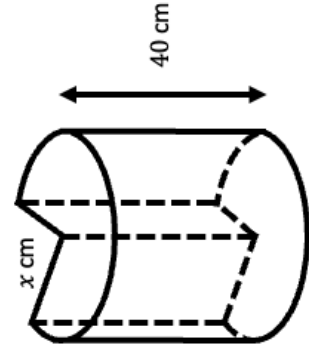

## Extension

**Q5** The cylinder and the cuboid have the same volume. Find the value of  $h$ .

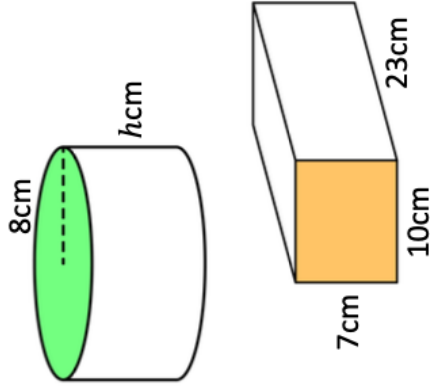

**Q6** Callum is filling cups with water. Each cup is a cylinder with radius 4cm and height 14cm. Callum has 10 litres of water. How many cups can Callum fill?

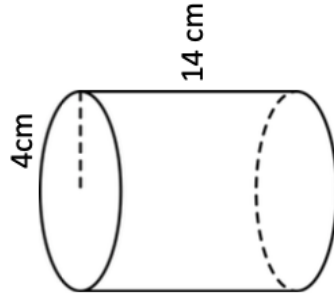

**Q7** The cross-section of the following prism is made by joining a semicircle and rectangle. Calculate the volume of the prism giving your answer to two significant figures.

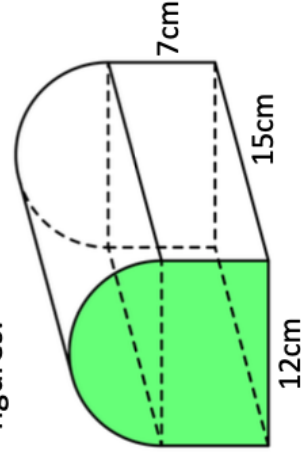

**Q8** Find the ratio of the volume of the triangular prism to the volume of the semi-cylinder. Give your answer in its simplest form.

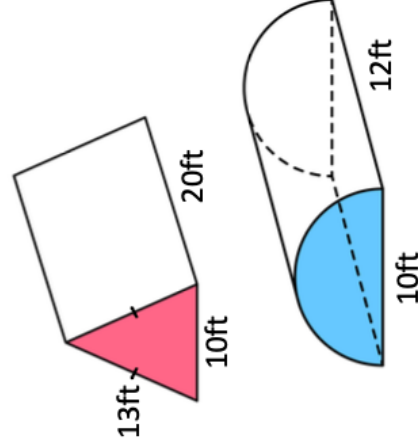



# Fluency Practice

Find the volume of each of these cylinders. Give your answers to 1 decimal place and include units.

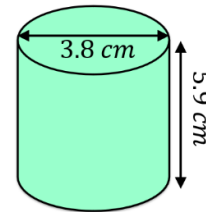
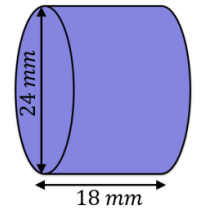
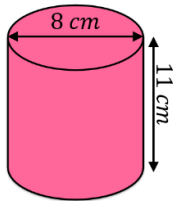
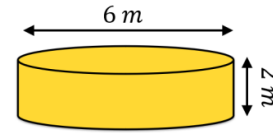
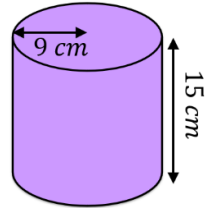
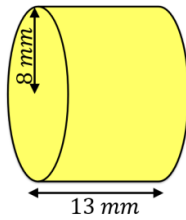
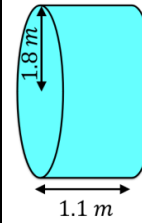
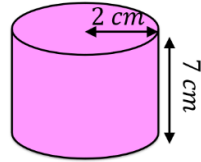
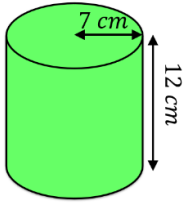

Find the missing measurements in these cylinders.

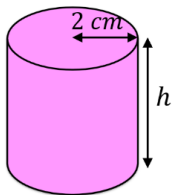

$Volume = 113 \text{ cm}^2$

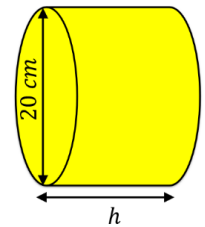

$Volume = 4084 \text{ cm}^2$

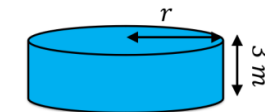

$Volume = 236 \text{ m}^2$

# Fluency Practice

Question 1: Work out the volume of each cylinder.  
Give each answer to one decimal place.

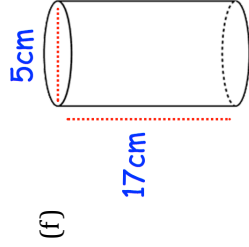
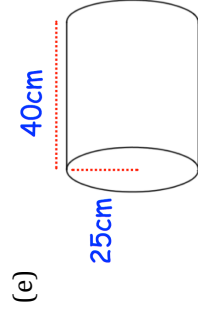
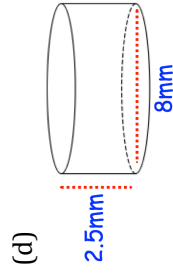
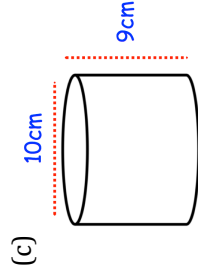
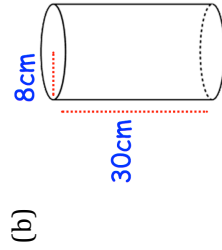
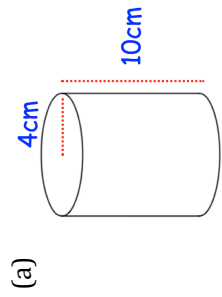

Question 2: Work out the volume of each cylinder.  
Give each answer in terms of  $\pi$ .

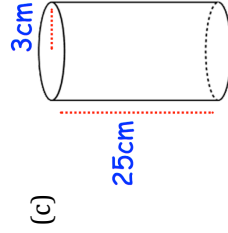
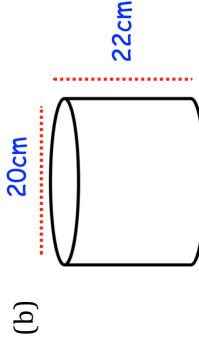
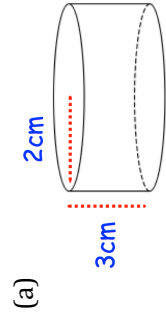

Question 3: Work out the height of each cylinder.  
Give each answer to one decimal place.

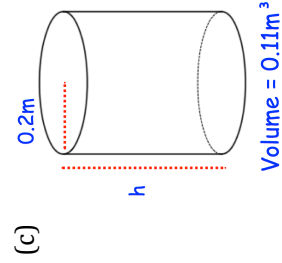
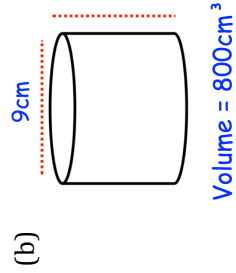
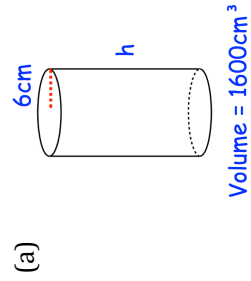

Question 4: Work out the value of  $x$ .  
Give each answer to one decimal place.

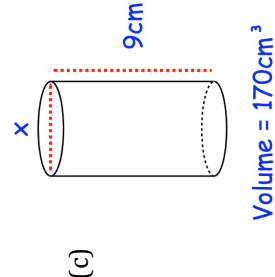
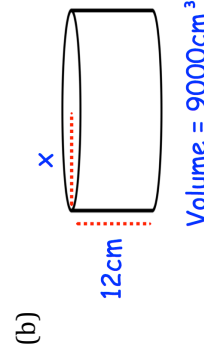
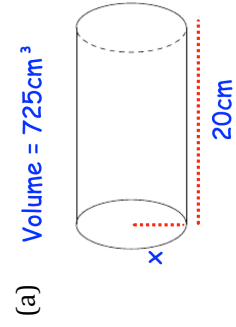

## Extension

Question 1: A cylindrical oil drum has a diameter of 48cm and a height of 92cm. Calculate the volume of the oil drum.

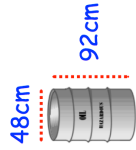

Question 2: A cylinder has a radius of 2m and a height of 5cm. Work out the volume of the cylinder in terms of  $\pi$ .

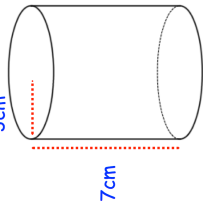

Question 3: Timothy is filling cups with orange juice. Each cup is a cylinder with radius 3cm and height 7cm. Timothy has 2 litres of orange juice. 1 litre = 1000cm<sup>3</sup>

How many cups can be filled?

Question 4: Shown below is a cylinder and a cube. The volume of the cylinder is equal to the volume of the cube. Find  $y$ .

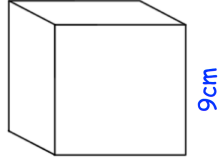
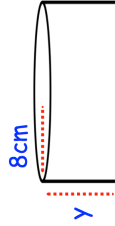

## Extension

Question 5: Calculate the volume of this shape.

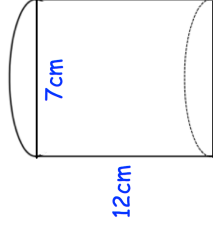

Question 6: 6 cylinders are placed in a crate as shown below.  
The radius of each cylinder is 4 cm and the height of each cylinder is 14 cm.  
The crate also has a height of 14 cm.

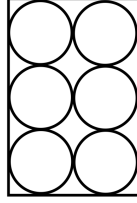

What percentage of space in the crate is empty?

Question 7: A solid glass cylinder has a radius of 1.5 cm and a height of 7.2 cm.  
The density of the glass is  $2.61 \text{ g/cm}^3$   
Work out the mass of the cylinder.

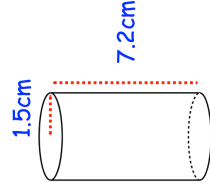

Question 8: The diagram shows a solid cylinder.  
The cylinder has radius of  $2y$  and height of  $6y$ .  
The cylinder is melted down and made into a sphere of radius  $r$ .

Express  $r$  in terms of  $y$ .

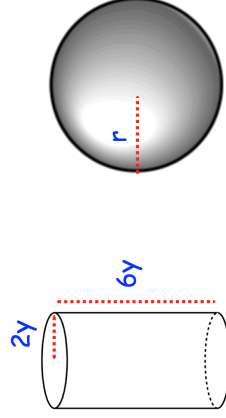

## Extension

### cylinder volume

(1)



the Subaru Impreza 2.0i has four cylinder heads, each with a diameter of 92mm and a stroke of 75mm

what is the total engine capacity?

(3)

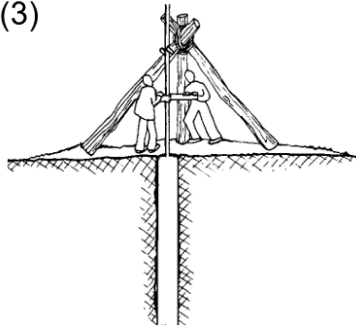

a well is dug as a cylinder with a diameter of 3 ft

if the depth of the water is measured to be 150 ft, how many gallons of water are there in the well?

$1 \text{ ft}^3 = 7.5 \text{ gallons}$

(2)

double the diameter, half the height

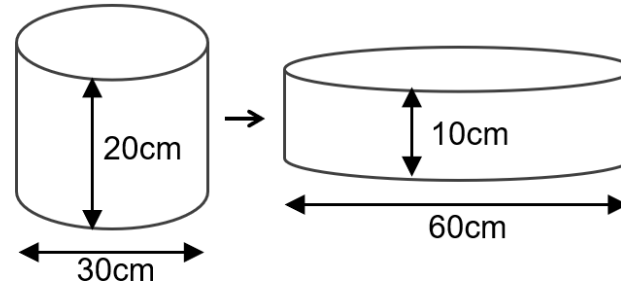

are the volumes the same?

(4)

the volume of a cylinder is  $1391.1 \text{ cm}^3$   
I forgot to write down the radius but do remember (since it was easy to remember) that the height was 12.3cm

what was the radius?

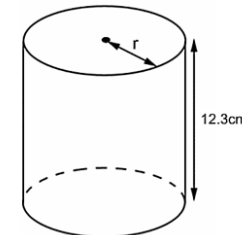

## Fluency Practice

**Q1** Calculate the surface of each of the following cylinders:  
**[i]** in terms of  $\pi$ , **[ii]** to 1dp.

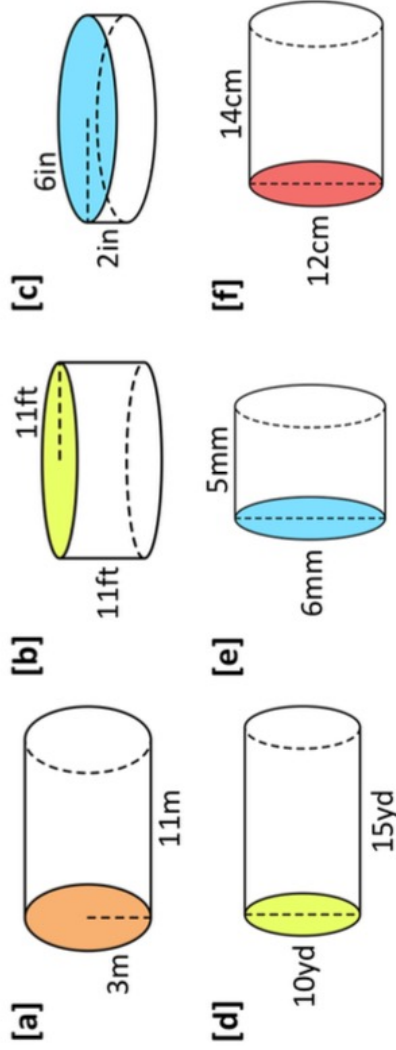

**Q2** Sam has a cylindrical fish tank with an open top. The tank has height 30cm and radius 20cm.

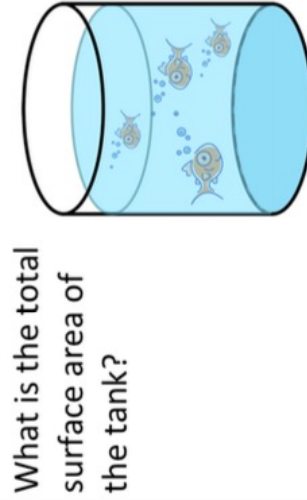

What is the total surface area of the tank?

**Q3**

A company manufactures and paints cylindrical chimneys with radius 12cm and height 25cm. The company has enough paint to cover a  $12\text{m}^2$  area. How many chimneys can the company paint?

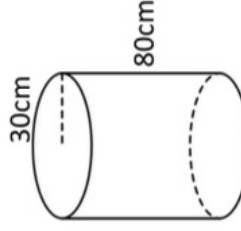

**Q4**

Calculate the curved surface area of the cylinder below. Give your answer to two decimal places.

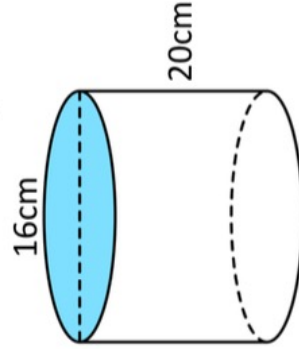

**Q5**

A cylindrical drinks bottle has a paper label wrapped around the outside. The label has a height of 7cm and the bottle has a radius of 3cm. The label also has a 1.5cm overlap so that it can be stuck together and held into place. Calculate the area of the label.

# Intelligent Practice

Calculate the total surface area. Give your answers in terms of  $\pi$  and to 1 decimal place.

**Question 1**

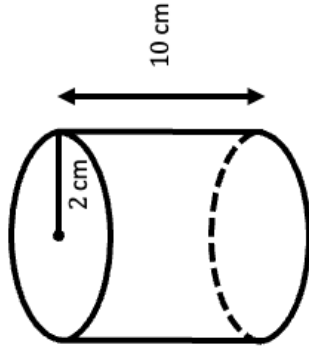

**Question 2**

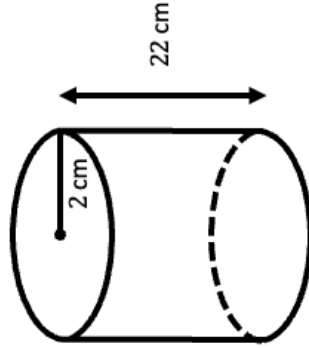

**Question 3**

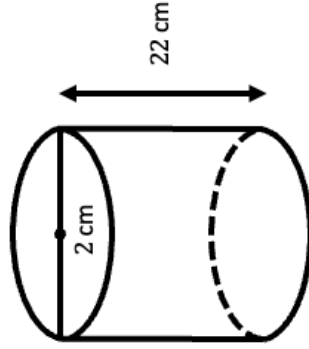

**Question 4**

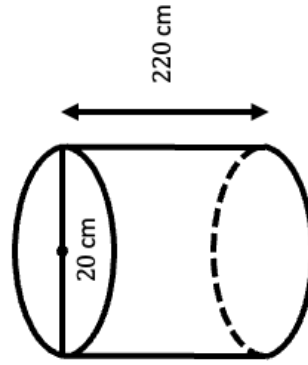

**Question 5**

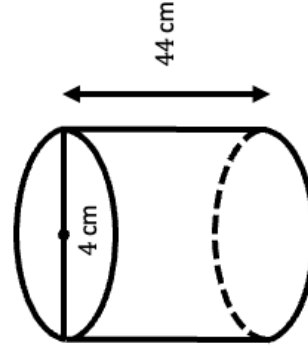

**Question 6**

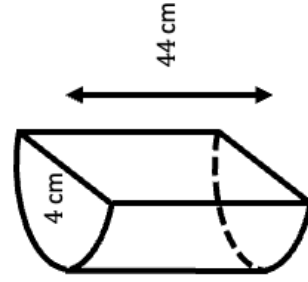

**Question 7**

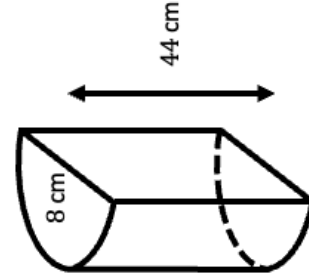

**Question 8**

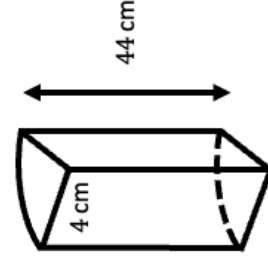

**Question 9**

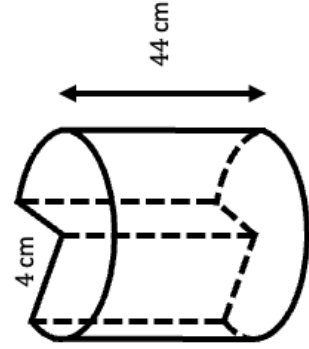

## Fluency Practice

**Ex3**

The following cylinder has surface area  $192\pi\text{cm}^2$ . Find its length,  $l\text{cm}$ .

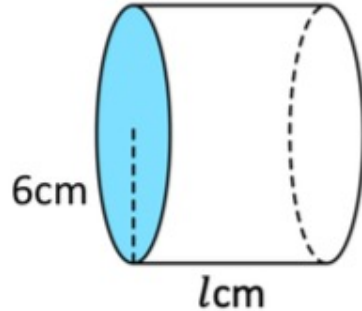

**Q1**

The following cylinder has surface area  $160\pi\text{cm}^2$ . Find its height,  $h\text{cm}$ .

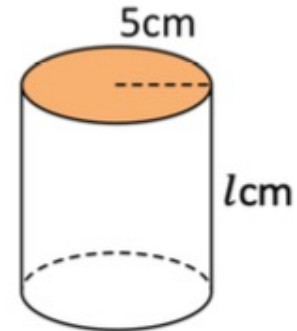

**Q2** Find the height of each cylinder.

**[a]**

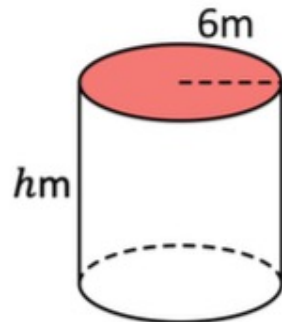

Surface area =  $240\pi\text{m}^2$

**[b]**

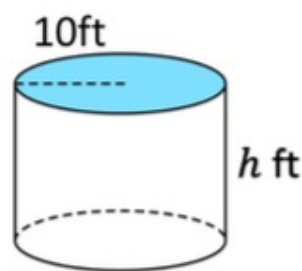

Surface area =  $380\pi\text{ft}^2$

**[c]**

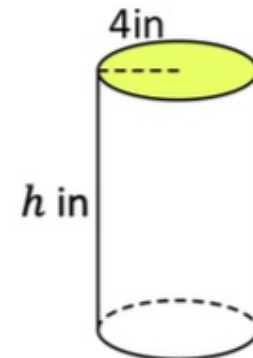

Surface area =  $176\pi\text{in}^2$



## Intelligent Practice

Find  $x$  given the total surface area. Give your answers to 1 decimal place if required.

**Question 1**

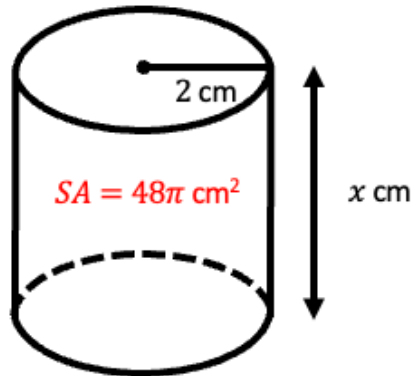

**Question 2**

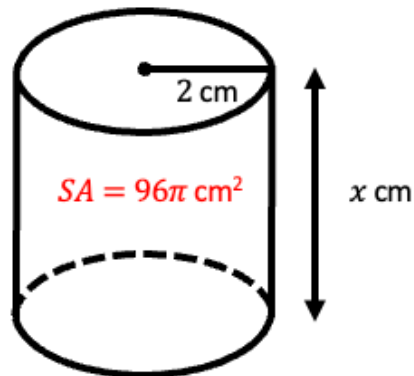

**Question 3**

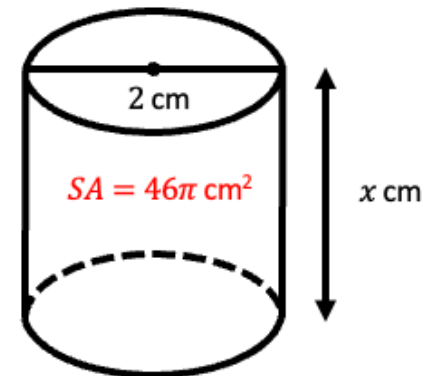

**Question 4**

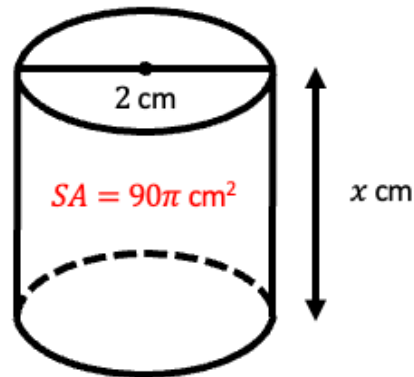

**Question 5**

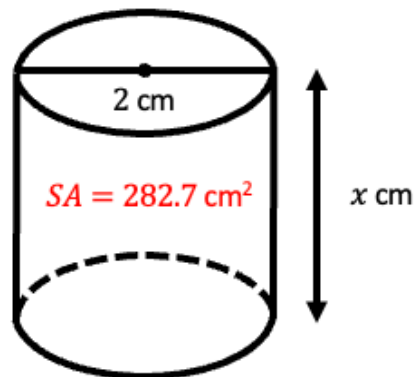

**Question 6**

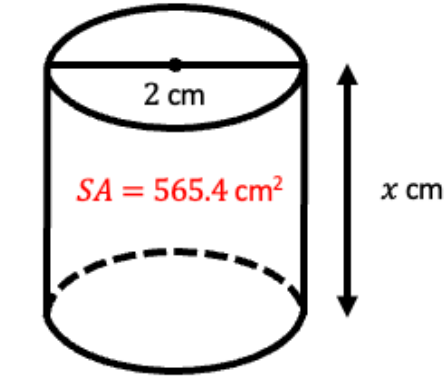

## Extension

**Q5**

The cross-section of the following prism is made by joining a semicircle and rectangle. Calculate the surface area of the prism giving your answer to three significant figures.

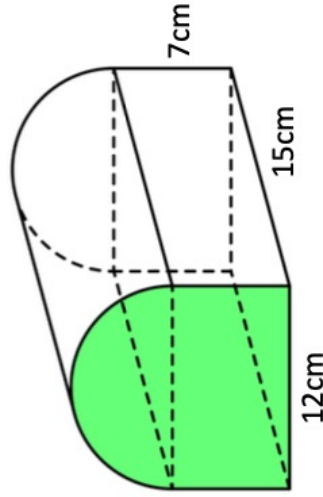

**Q6**

Shown is a triangular prism and a semi-cylinder. Which solid has the largest surface area?

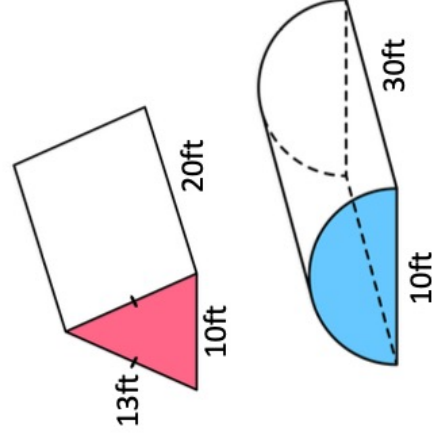

**Q7**

The following cylinder has surface area  $392\pi\text{cm}^2$ .

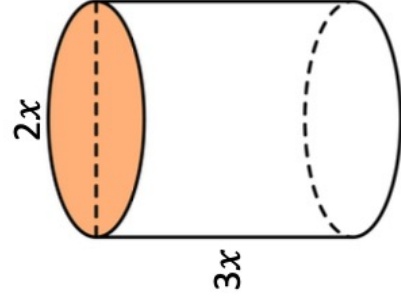

Find  $x$ .

**Q8**

The cylinder and the cuboid have the same surface area. Express  $h$  in terms of  $r$ .

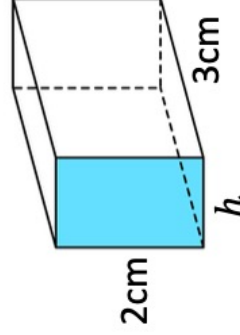
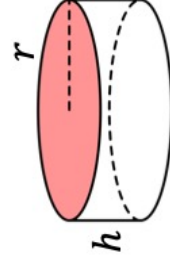

# Fluency Practice

Find the total surface areas of these cylinders.

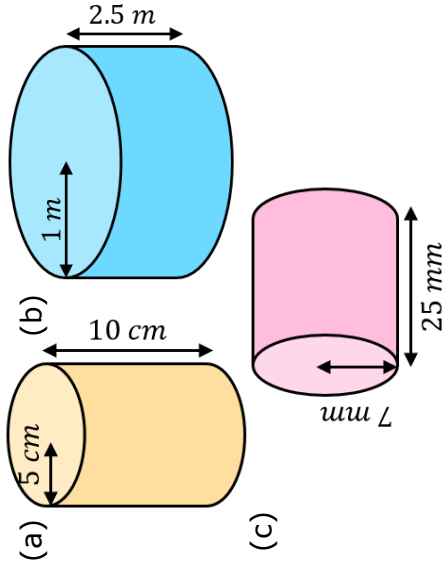

Find the total surface areas of these cylinders.

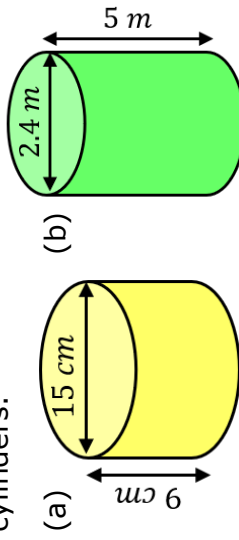

Find the total surface areas of these cylinders, leaving your answer in terms of  $\pi$ .

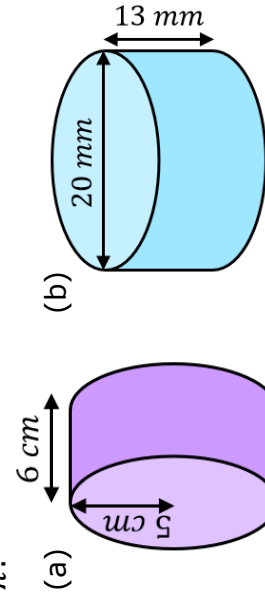

Find the missing lengths in these cylinders.

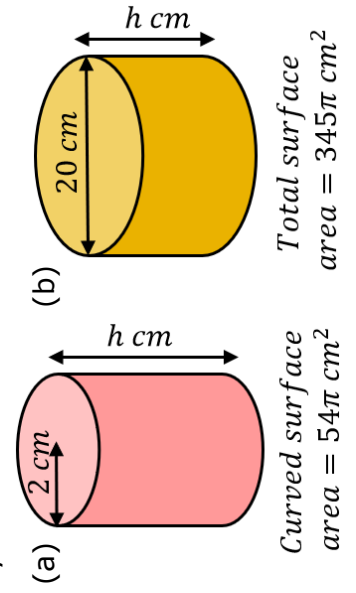

# Fluency Practice

Question 1: Work out the surface area of each of the following cylinders.  
Give each answer to 2 decimal places.

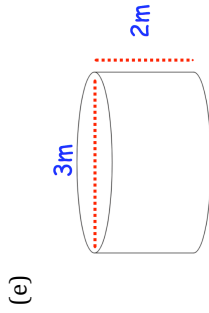
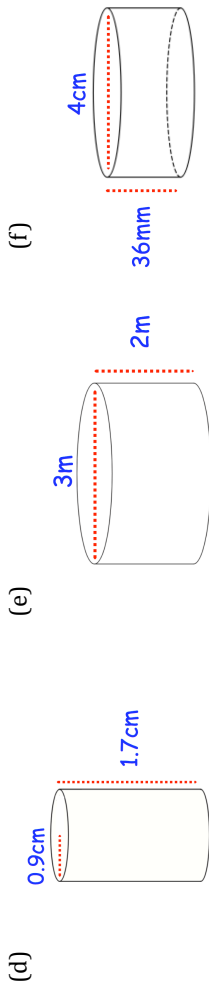
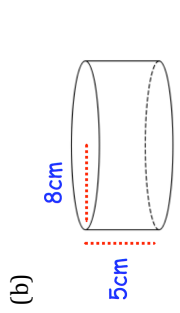
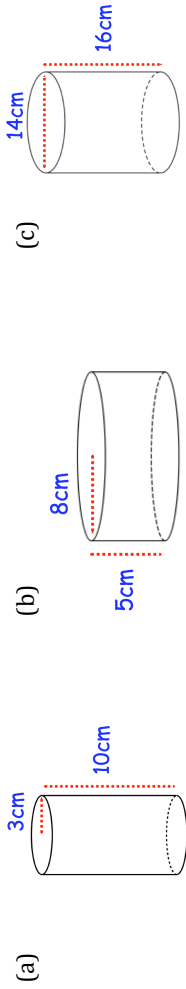

Question 2: Work out the surface area of each of the following cylinders.  
Leave your answers in terms of  $\pi$

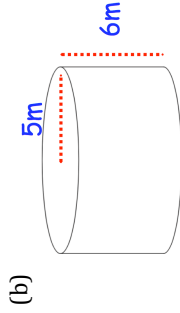
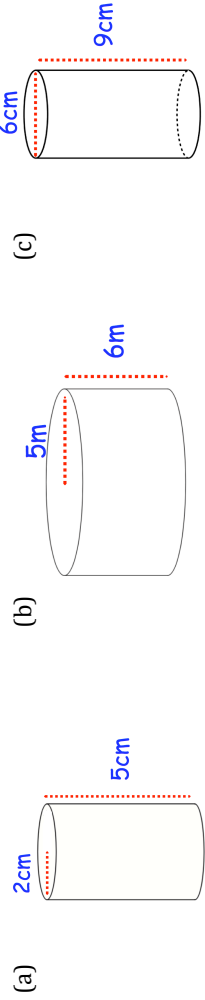

Question 3: Work out the height of each cylinder below

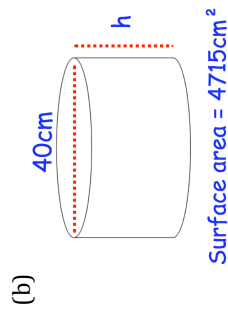
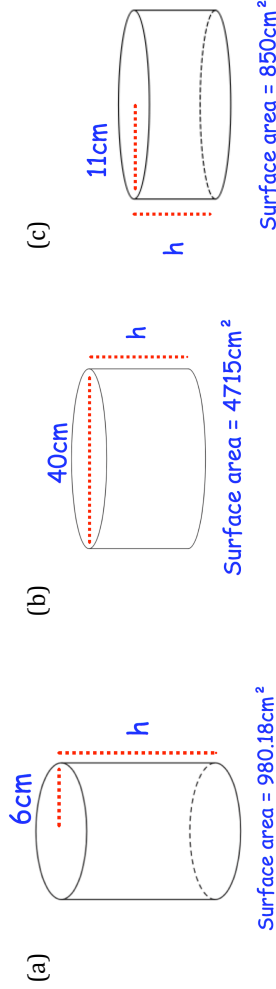

Question 4: Work out the height of each cylinder below

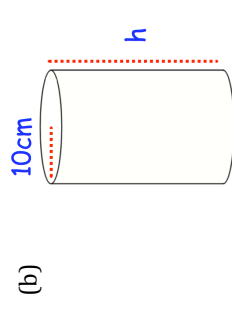
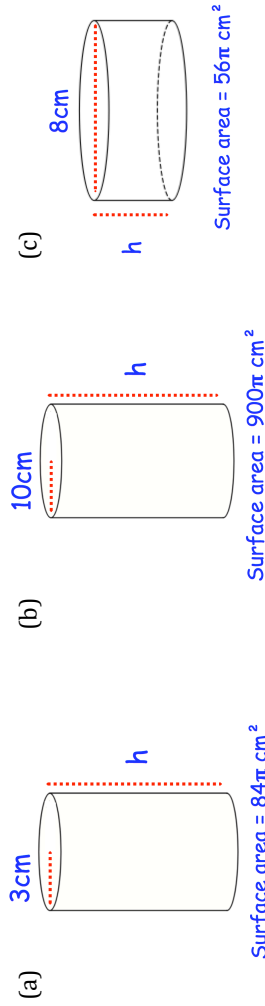

Question 5: Work out the radius of each cylinder below

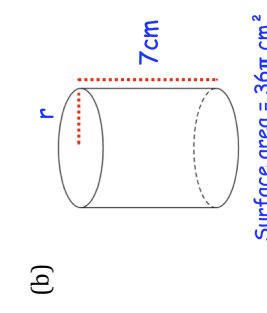
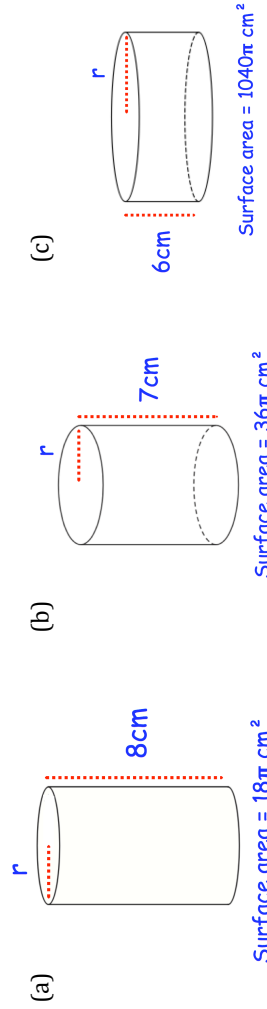

## Extension

Question 1: The cylinder and cube below have the same surface area.  
Find the side length of the cube,  $x$ .

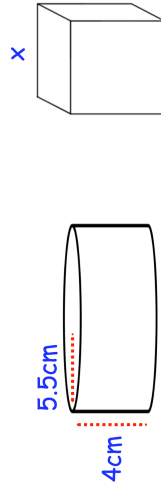

Question 2: A can of baked beans has a paper label wrapped around the outside. The can has a height of 11 cm and radius of 4.5 cm. The label covers the entire height of the can. The label has a 1 cm overlap vertically so that it can be stuck together. Calculate the area of the label.

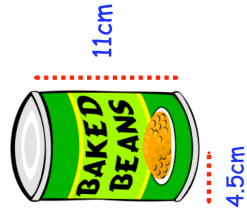

## Extension

Question 3: The cylinder below has a surface area of  $972\pi \text{ cm}^2$ .  
Find  $x$ .

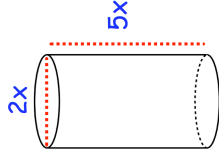

Question 4: A cylinder has a height of  $18\text{cm}$  and volume of  $1715\text{cm}^3$ .  
Work out the surface area of the cylinder.

Question 5: A cylinder and a cone are joined together to make a solid.  
The cylinder has a radius of  $9\text{cm}$  and height of  $13\text{cm}$ .  
The cone has a slant height of  $15\text{cm}$ .  
Find the total surface area of the solid.

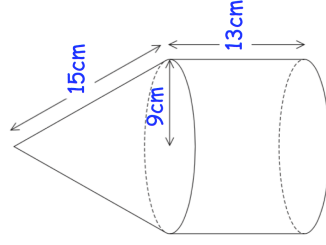

Question 6: Work out the surface area of the shape below.

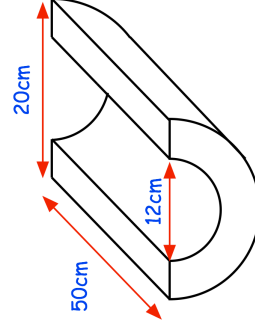

# Fluency Practice

Find the volume and total surface area of each of these cylinders.

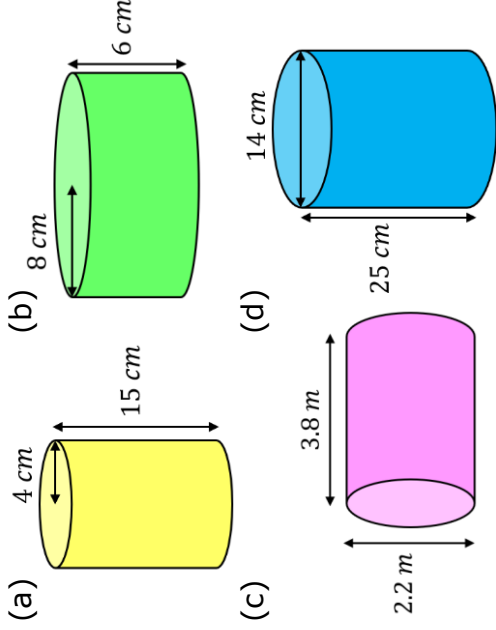

(a) Find the volume and surface area of a soup tin with a radius of  $4.5\text{ cm}$  and a height of  $12.5\text{ cm}$ .

(b) Find the volume and **curved** surface area of a glue stick with a diameter of  $26\text{ mm}$  and a height of  $70\text{ mm}$ .

Find the missing lengths.

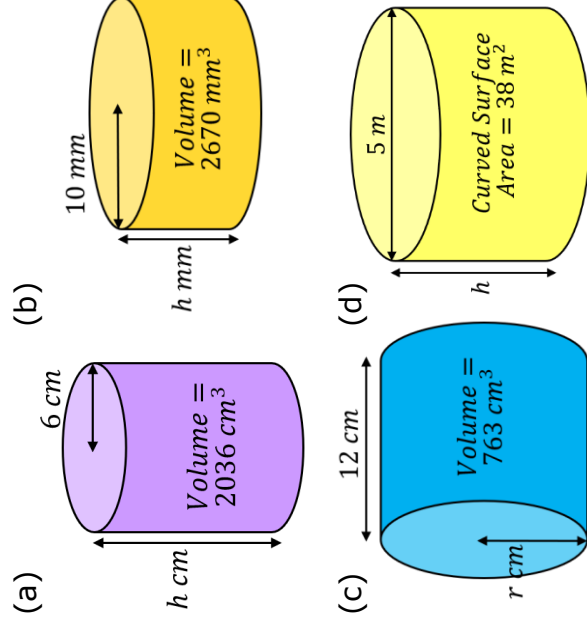

A cylinder has a height of  $16\text{ cm}$  and a curved surface area of  $452\text{ cm}^2$ . Find its volume.

## Fluency Practice

1. Work out the volume of each of these cylinders. Give your answers both in terms of  $\pi$ , and correct to 3 significant figures.

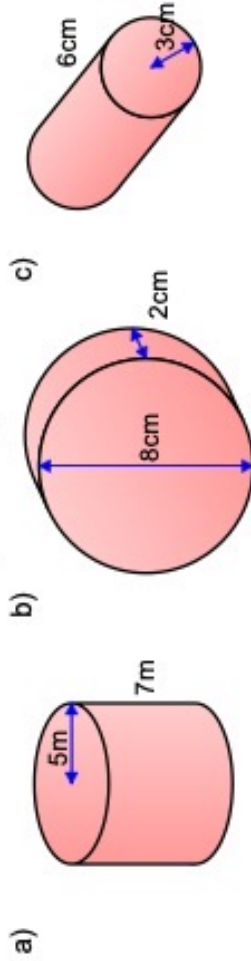

2. These two cylinders have the same volume. Work out the value of  $h$ .

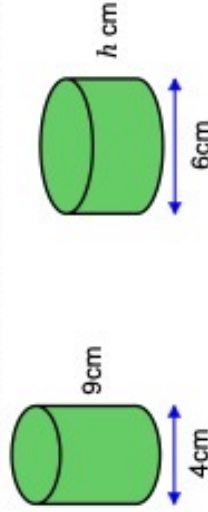

3. A cylinder fits snugly inside a cube, such that the cylinder touches each face of the cube.

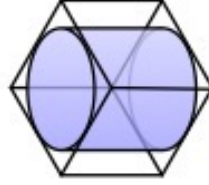

Work out the percentage of the volume of the cube that is not taken up by the cylinder.

4. Work out the surface area of each of these cylinders, correct to 3 significant figures:

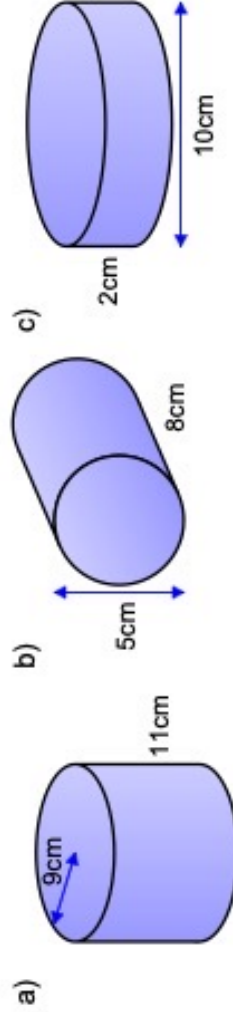

5. A cylindrical pipe has radius 5cm. The pipe is completely full of water that is moving along the pipe at a speed of 0.5m/s.

Work out the flow rate of the water in  $\text{cm}^3/\text{s}$ .



## Completion Table

# Volume and Surface Area of a Cylinder

	$r$	$d$	$h$	Volume	Surface Area
a.	2		10		
b.	2		7		
c.		6	3		
d.			5	$45\pi$	
e.	4			$32\pi$	
f.			23	$23\pi$	
g.	1				$36\pi$
h.		12		$1188\pi$	
i.			45	$1620\pi$	
j.			0.5		$36\pi$

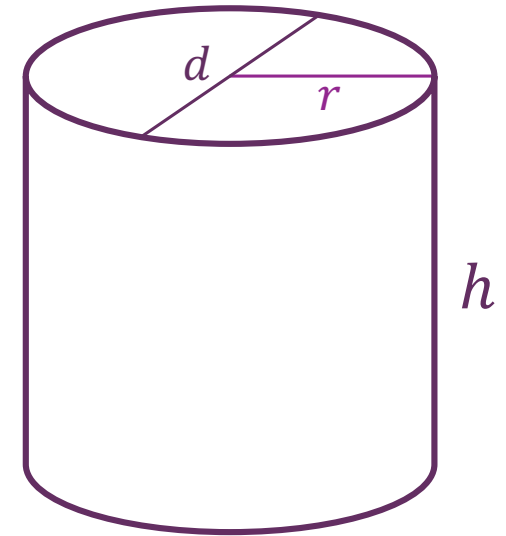

# Fluency Practice

## volume & surface area

Calculate the surface area and volume of each of these solids.

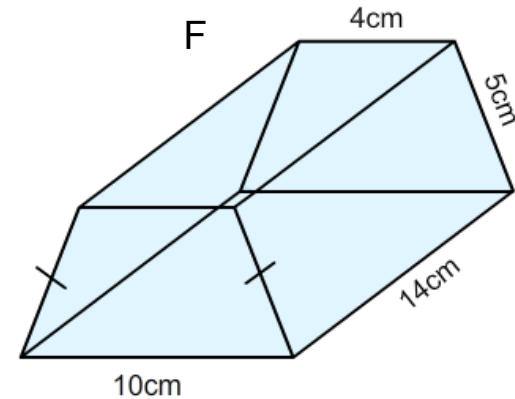
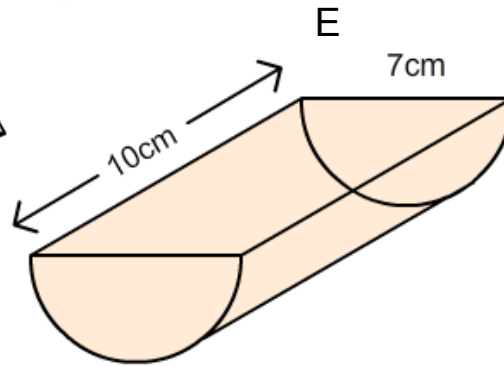
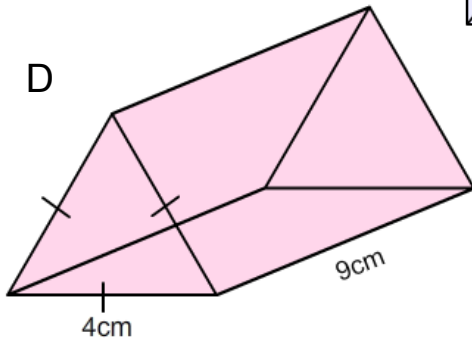
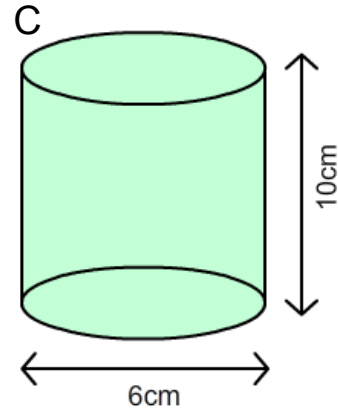
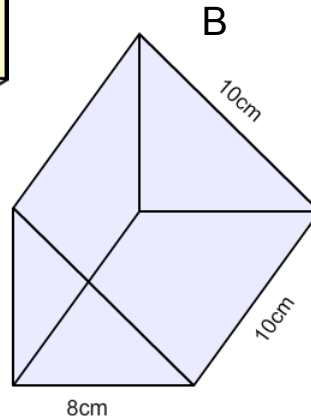
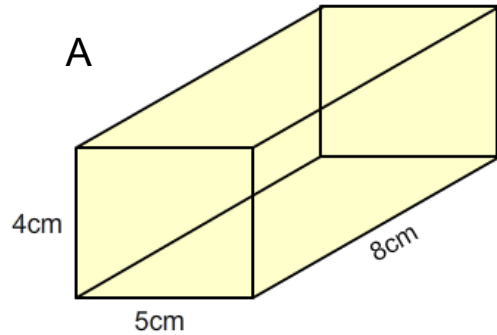

Shape	Volume (cm <sup>3</sup> )	Surface Area (cm <sup>2</sup> )
A		
B		
C		
D		
E		
F		

# Fluency Practice

## Volume & Surface Area of Cylinders & Prisms

Find the volume & surface area of these solid shapes. Units are centimetres.

1) A square-based prism

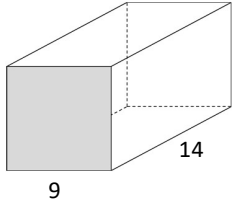

2)

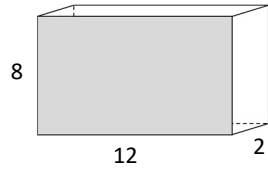

3)

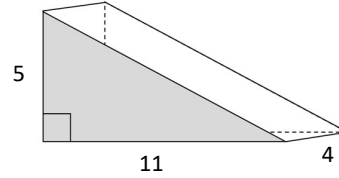

4)

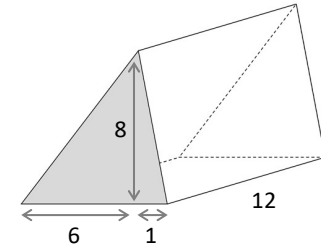

5) A right parallelepiped

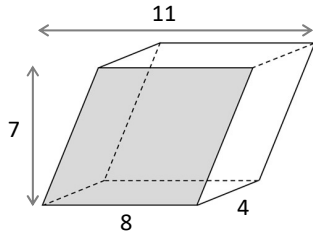

6)

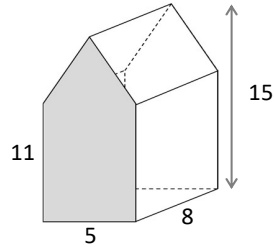

7) A right-trapezium-based prism

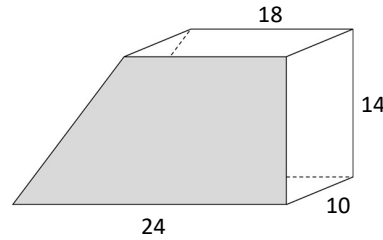

8) A trapezium-based prism

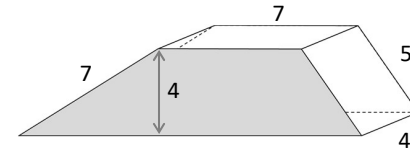

9)

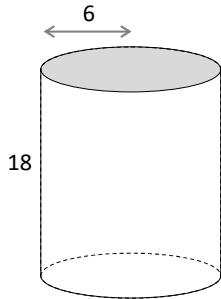

10)

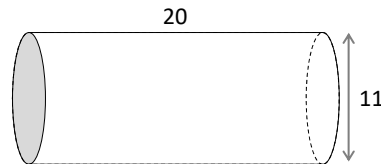

11) A half cylinder

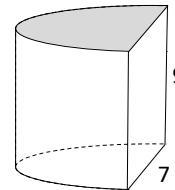

12) A three-quarter cylinder

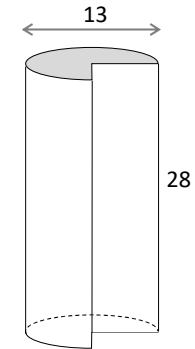

# Problem Solving

Each prism has the same volume.

Prism A

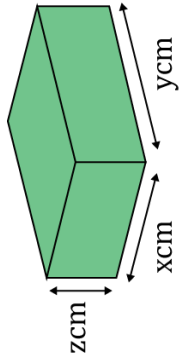

Prism B

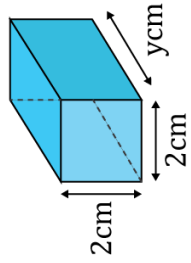

Prism C

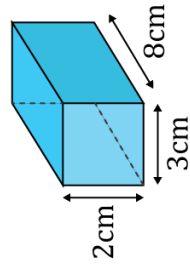

Prism D

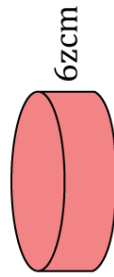

Prism E

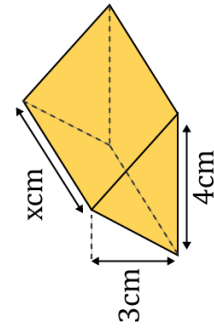

## 5 Area and Volume Unit Conversions

## Intelligent Practice

Convert:

- 1) 90000  $\text{cm}^2$  to  $\text{m}^2$
- 2) 900  $\text{cm}^2$  to  $\text{m}^2$
- 3) 90000  $\text{mm}^2$  to  $\text{m}^2$
- 4) 90  $\text{m}^2$  to  $\text{cm}^2$
- 5) 9  $\text{m}^2$  to  $\text{cm}^2$
- 6) 9  $\text{cm}^2$  to  $\text{m}^2$
- 7) 0.9  $\text{m}^2$  to  $\text{cm}^2$
- 8) 0.04  $\text{m}^2$  to  $\text{cm}^2$
- 9) 0.04  $\text{m}^2$  to  $\text{mm}^2$
- 10) 36  $\text{km}^2$  to  $\text{m}^2$
- 11) 3.6  $\text{km}^2$  to  $\text{m}^2$
- 12) 0.1  $\text{km}^2$  to  $\text{m}^2$
- 13) 0.1  $\text{m}^2$  to  $\text{km}^2$

# Fluency Practice

Question 1: Shown is a rectangle with length 3m and width 2m

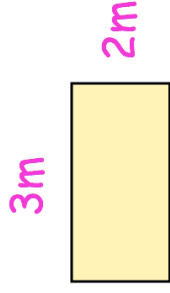

- (a) Find the area of the rectangle in  $\text{m}^2$
- (b) What is the length of the rectangle in cm?
- (c) What is the width of the rectangle in cm?
- (d) Find the area of the rectangle in  $\text{cm}^2$
- (e) Fill in the missing number using your answers to (a) and (d)

$$1\text{m}^2 = \boxed{\phantom{000}} \text{cm}^2$$

Question 2: Convert the following areas into  $\text{cm}^2$

- (a)  $5\text{m}^2$
- (b)  $9\text{m}^2$
- (c)  $25\text{m}^2$
- (d)  $104\text{m}^2$
- (e)  $0.7\text{m}^2$
- (f)  $4.3\text{m}^2$
- (g)  $0.09\text{m}^2$
- (h)  $60.2\text{m}^2$

Question 3: Convert the following areas into  $\text{m}^2$

- (a)  $40,000\text{cm}^2$
- (b)  $70,000\text{cm}^2$
- (c)  $180,000\text{cm}^2$
- (d)  $600,000\text{cm}^2$
- (e)  $3,830,000\text{cm}^2$
- (f)  $2,500\text{cm}^2$
- (g)  $900\text{cm}^2$
- (h)  $4,421\text{cm}^2$
- (i)  $12\text{cm}^2$

Question 4: Shown is a rectangle with length 5cm and width 3cm

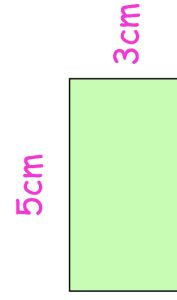

- (a) Find the area of the rectangle in  $\text{cm}^2$
- (b) What is the length of the rectangle in mm?
- (c) What is the width of the rectangle in mm?
- (d) Find the area of the rectangle in  $\text{mm}^2$
- (e) Fill in the missing number using your answers to (a) and (d)

$$1\text{cm}^2 = \boxed{\phantom{000}} \text{mm}^2$$

Question 5: Convert the following areas into  $\text{mm}^2$

- (a)  $2\text{cm}^2$
- (b)  $8\text{cm}^2$
- (c)  $35\text{cm}^2$
- (d)  $730\text{cm}^2$
- (e)  $0.6\text{cm}^2$
- (f)  $1.4\text{cm}^2$
- (g)  $0.03\text{cm}^2$
- (h)  $0.057\text{cm}^2$

Question 6: Convert the following areas into  $\text{cm}^2$

- (a)  $500\text{mm}^2$
- (b)  $400\text{mm}^2$
- (c)  $2,200\text{mm}^2$
- (d)  $8,000\text{mm}^2$
- (e)  $91,000\text{mm}^2$
- (f)  $20\text{mm}^2$
- (g)  $17\text{mm}^2$
- (h)  $5\text{mm}^2$
- (i)  $0.3\text{mm}^2$

Question 7: Convert  $6\text{m}^2$  to  $\text{mm}^2$

## Extension

Question 1: Shown below are three shapes (not drawn accurately).

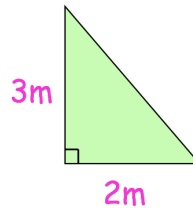

Shape A



Shape B

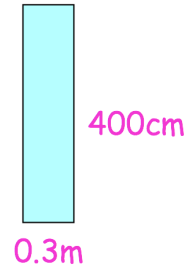

Shape C

List the shapes in order of area, from smallest to greatest.

Question 2: Tommy has been asked to change  $800\text{cm}^2$  into  $\text{m}^2$   
He says:

“since there are 100 centimetres in 1 metres, the answer is  $8\text{m}^2$ ”

Explain why Tommy is incorrect.

Question 3: Rebecca is tiling her kitchen floor.  
The floor is a rectangle, measuring 8m by 6m.  
Each tile is a square measuring 20cm by 20cm.  
The tiles are sold in boxes of 10 and each box costs £8.50

Work out the total cost of the tiles needed for the kitchen floor.



## Interwoven Maths – Converting Units of Area with Standard Form

Calculate the following, giving **all** your answers in standard form.

- 1) a) Convert  $0.4 \text{ mm}^2$  into  $\text{km}^2$ .  
b) Convert  $8000 \text{ m}^2$  into  $\text{km}^2$ .  
c) How many tiles of area  $0.4 \text{ mm}^2$  would it take to fill an area of  $8000 \text{ m}^2$ ?
- 2) a) Calculate how many square centimetres there are in  $2 \text{ km}^2$   
b) Calculate many square centimetres there are in  $90\,000 \text{ m}^2$ .  
c) A farmer has farms measuring  $2 \text{ km}^2$  and  $90\,000 \text{ m}^2$ . Find the total area of her land in  $\text{cm}^2$ .
- 3) a) Convert  $3 \times 10^{12} \text{ mm}^2$  into square metres.  
b) Convert  $4 \times 10^{-2} \text{ km}^2$  into square metres.  
A small island has an area of  $3 \times 10^{12} \text{ mm}^2$ . Each year, erosion reduces its area by  $4 \times 10^{-2} \text{ km}^2$ .  
c) What will the area of the island be one year from now in square metres?  
d) How many years will it take for the island disappear entirely?
- 4) The Moon has a surface area of  $1.44 \times 10^7 \text{ km}^2$ . The sole of my shoe has an area of roughly  $2.4 \times 10^4 \text{ mm}^2$ .  
By converting both areas to  $\text{m}^2$ , approximate how many steps it would take to walk on the Moon's entire surface.

## Intelligent Practice

Convert:

1)  $2 \text{ cm}^3$  to  $\text{mm}^3$

2)  $2 \text{ mm}^3$  to  $\text{cm}^3$

3)  $2 \text{ m}^3$  to  $\text{cm}^3$

4)  $2 \text{ km}^3$  to  $\text{m}^3$

5)  $0.002 \text{ km}^3$  to  $\text{m}^3$

6)  $0.00002 \text{ cm}^3$  to  $\text{mm}^3$

7)  $0.4 \text{ m}^3$  to  $\text{cm}^3$

8)  $0.04 \text{ m}^3$  to  $\text{cm}^3$

9)  $0.04 \text{ m}^3$  to  $\text{mm}^3$

10)  $0.0016 \text{ km}^3$  to  $\text{m}^3$

11)  $0.00016 \text{ km}^3$  to  $\text{m}^3$

12)  $0.1 \text{ km}^3$  to  $\text{m}^3$

13)  $0.1 \text{ m}^3$  to  $\text{km}^3$

## Fluency Practice

- 1) Convert 1900 litres to  $\text{m}^3$
  - 2) Convert 4000 litres to  $\text{m}^3$
  - 3) Convert 85.4 litres to  $\text{cm}^3$
  - 4) Convert 3100 litres to  $\text{m}^3$
  - 5) Convert 3900 litres to  $\text{m}^3$
  - 6) Convert 3400 litres to  $\text{m}^3$
  - 7) Convert 9000 litres to  $\text{m}^3$
  - 8) Convert 9.3 litres to  $\text{cm}^3$
  - 9) Convert 16.8 litres to  $\text{cm}^3$
  - 10) Convert 3500 litres to  $\text{m}^3$
- 1) Convert 18300  $\text{cm}^3$  to litres
  - 2) Convert 987000  $\text{cm}^3$  to litres
  - 3) Convert 71500  $\text{cm}^3$  to litres
  - 4) Convert 9.3  $\text{m}^3$  to litres
  - 5) Convert 9.7  $\text{m}^3$  to litres
  - 6) Convert 7.9  $\text{m}^3$  to litres
  - 7) Convert 697000  $\text{cm}^3$  to litres
  - 8) Convert 7.5  $\text{m}^3$  to litres
  - 9) Convert 478000  $\text{cm}^3$  to litres
  - 10) Convert 4.8  $\text{m}^3$  to litres

# Fluency Practice

Question 1: Shown is a cube with side length 1m

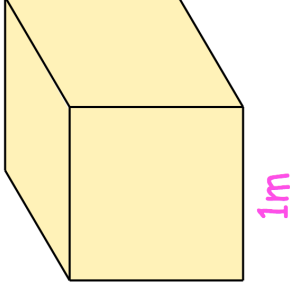

- (a) Find the volume of the cube in  $m^3$
- (b) What is the side length of the cube in cm?
- (c) Find the volume of the cube in  $cm^3$
- (d) Fill in the missing number using your answers to (a) and (c)

$$1m^3 = \boxed{\phantom{000}} cm^3$$

Question 2: Convert the following volumes into  $cm^3$

- (a)  $3m^3$
  - (b)  $11m^3$
  - (c)  $80m^3$
  - (d)  $205m^3$
  - (e)  $0.5m^3$
  - (f)  $0.17m^3$
  - (g)  $0.006m^3$
  - (h)  $4,000m^3$
- Question 3: Convert the following volumes into  $m^3$
- (a)  $7,000,000cm^3$
  - (b)  $33,000,000cm^3$
  - (c)  $190,000,000cm^3$
  - (d)  $200,000cm^3$
  - (e)  $45,000cm^3$
  - (f)  $1,000,000,000cm^3$

Question 4: Shown is a cube with side length 1cm

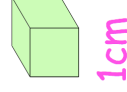

- (a) Find the volume of the cube in  $cm^3$
- (b) What is the side length of the cube in mm?
- (c) Find the volume of the cube in  $mm^3$
- (d) Fill in the missing number using your answers to (a) and (c)

$$1cm^3 = \boxed{\phantom{000}} mm^3$$

## Fluency Practice

Question 5: Convert the following volumes into  $\text{mm}^3$

- (a)  $6\text{cm}^3$  (b)  $75\text{cm}^3$  (c)  $300\text{cm}^3$  (d)  $0.9\text{cm}^3$   
(e)  $0.01\text{cm}^3$  (f)  $0.008\text{cm}^3$  (g)  $27.52\text{cm}^3$

Question 6: Convert the following volumes into  $\text{cm}^3$

- (a)  $4,000\text{mm}^3$  (b)  $88,000\text{mm}^3$  (c)  $500,000\text{mm}^3$  (d)  $300\text{mm}^3$   
(e)  $2\text{mm}^3$  (f)  $100.5\text{mm}^3$  (g)  $60,000,000\text{mm}^3$

Question 7: Convert  $2\text{m}^3$  to  $\text{mm}^3$

Question 8: Given 1 litre =  $1000\text{cm}^3$

Convert each of the following into  $\text{cm}^3$

- (a) 2 litres (b) 9 litres (c) 30 litres (d) 18 litres  
(e) 0.4 litres (f) 500ml (g) 7,500 litres (h) 330ml  
(i) 15ml (j) 7.5ml (k) 1ml

Question 9: Convert each of the following into litres

- (a)  $5,000\text{cm}^3$  (b)  $2,400\text{cm}^3$  (c)  $20,000\text{cm}^3$  (d)  $400\text{cm}^3$

## Extension

Question 1: Tommy has been asked to change  $2\text{m}^3$  into  $\text{cm}^3$   
He says:

“since there are 100 centimetres in 1 metres, the answer is  $200\text{m}^3$ ”

Explain why Tommy is incorrect.

Question 2: Shown below are three containers of water.  
The amount of water in each is shown.

List the containers in order, from greatest to least.

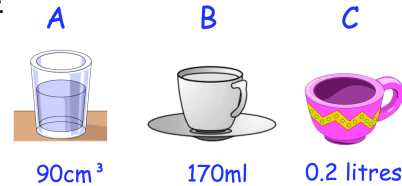

Question 3: Shown below is a fish tank.

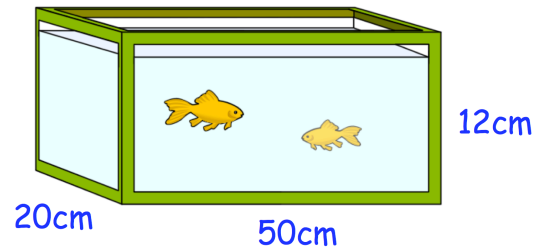

The fish tank is emptied and then filled with clean water.  
The water is poured in at a rate of 25ml every second.  
How long will it take to fill the fish tank?

Question 4: A cube has a volume of  $0.008\text{m}^3$   
Work out the surface area of the cube.  
Give your answer in  $\text{cm}^2$

## Fluency Practice

Convert the following units of area.

- (a)  $5 \text{ cm}^2$  into  $\text{mm}^2$
- (b)  $8 \text{ cm}^2$  into  $\text{mm}^2$
- (c)  $6.5 \text{ cm}^2$  into  $\text{mm}^2$
- (d)  $200 \text{ mm}^2$  into  $\text{cm}^2$
- (e)  $1300 \text{ mm}^2$  into  $\text{cm}^2$
- (f)  $750 \text{ mm}^2$  into  $\text{cm}^2$

Convert the following units of area.

- (a)  $7 \text{ m}^2$  into  $\text{cm}^2$
- (b)  $3 \text{ m}^2$  into  $\text{cm}^2$
- (c)  $0.9 \text{ m}^2$  into  $\text{cm}^2$
- (d)  $30000 \text{ cm}^2$  into  $\text{m}^2$
- (e)  $67000 \text{ cm}^2$  into  $\text{m}^2$
- (f)  $8000 \text{ cm}^2$  into  $\text{m}^2$

Convert the following units of volume.

- (a)  $6 \text{ cm}^3$  into  $\text{mm}^3$
- (b)  $2.5 \text{ cm}^3$  into  $\text{mm}^3$
- (c)  $41 \text{ cm}^3$  into  $\text{mm}^3$
- (d)  $800 \text{ mm}^3$  into  $\text{cm}^3$
- (e)  $1200 \text{ mm}^3$  into  $\text{cm}^3$
- (f)  $90 \text{ mm}^3$  into  $\text{cm}^3$

Convert the following units of volume.

- (a)  $6 \text{ m}^3$  into  $\text{cm}^3$
- (b)  $2.5 \text{ m}^3$  into  $\text{cm}^3$
- (c)  $41 \text{ m}^3$  into  $\text{cm}^3$
- (d)  $8000000 \text{ cm}^3$  into  $\text{m}^3$
- (e)  $3000000 \text{ cm}^3$  into  $\text{m}^3$
- (f)  $900000 \text{ cm}^3$  into  $\text{m}^3$

Convert the following units of capacity.

- (a)  $5000 \text{ cm}^3$  in ml
- (b)  $5000 \text{ cm}^3$  in litres
- (c)  $2500 \text{ cm}^3$  in litres
- (d)  $250 \text{ cm}^3$  in litres
- (e)  $25 \text{ cm}^3$  in litres

## Fluency Practice

<b>A1</b> Convert 15 metres into cm	<b>A2</b> Convert 23 cm into mm	<b>A3</b> Convert 29 metres into km	<b>A4</b> Convert 71 mm into metres
<b>B1</b> Convert $2 \text{ m}^2$ into $\text{cm}^2$	<b>B2</b> Convert $54 \text{ cm}^2$ into $\text{mm}^2$	<b>B3</b> Convert $900 \text{ cm}^2$ into $\text{m}^2$	<b>B4</b> Convert $8 \text{ km}^2$ into $\text{m}^2$
<b>C1</b> Convert $15 \text{ cm}^3$ into $\text{mm}^3$	<b>C2</b> Convert $12 \text{ m}^3$ into $\text{cm}^3$	<b>C3</b> Convert $4 \text{ km}^3$ into $\text{m}^3$	<b>C4</b> Convert $40 \text{ mm}^3$ into $\text{cm}^3$
<b>D1</b> Convert $18 \text{ mm}^2$ into $\text{cm}^2$	<b>D2</b> Convert 6 km into cm	<b>D3</b> Convert $250 \text{ cm}^3$ into $\text{m}^3$	<b>D4</b> Convert $14 \text{ m}^2$ into $\text{mm}^2$
<b>E1</b> Convert $380 \text{ m}^2$ into $\text{km}^2$	<b>E2</b> Convert $4.5 \text{ cm}^3$ into $\text{mm}^3$	<b>E3</b> Convert 940 mm into km	<b>E4</b> Convert $3 \text{ km}^2$ into $\text{cm}^2$



## Fluency Practice

Converting Units of Area and Volume		
(a)	(b)	(c)
<p>Which is the greater area? <math>5000 \text{ mm}^2</math> or <math>5 \text{ cm}^2</math></p>	<p>A rectangle measures <math>6 \text{ cm}</math> by <math>5 \text{ cm}</math>. Find the area of the rectangle:</p> <p>(i) in <math>\text{cm}^2</math></p> <p>(ii) in <math>\text{mm}^2</math></p>	<p>Which is the greater volume? <math>0.08 \text{ m}^3</math> or <math>8000 \text{ cm}^3</math></p>
(d)	(e)	(f)
<p>A fish tank has dimensions <math>80 \text{ cm}</math> by <math>60 \text{ cm}</math> by <math>35 \text{ cm}</math>. It is filled with water. How many litres of water does it contain?</p>	<p>A cube has side length <math>6 \text{ cm}</math>. Find the volume of the cube:</p> <p>(i) in <math>\text{cm}^3</math></p> <p>(ii) in <math>\text{m}^3</math></p>	<p>A kitchen floor has an area of <math>9 \text{ m}^2</math>. Charles wants to varnish the floor. It costs <math>\text{£}2.45</math> for a tin of varnish which covers <math>1500 \text{ cm}^2</math> of floor. How much will it cost to varnish the floor?</p>
(g)	(h)	(i)
<p>Coco has <math>0.005 \text{ m}^3</math> of orange juice. She wants to fill as many glasses as possible with juice. Each glass holds <math>210 \text{ cm}^3</math>. How many glasses can Coco completely fill?</p>	<p>A standard bin holds 240 litres of rubbish. A refuse lorry can hold <math>26 \text{ m}^3</math> of waste. How many full bins could be emptied into the lorry before it is full?</p>	<p>Which has the greatest volume? A cuboid with a capacity of 0.6 litres, a prism with a cross section of <math>5000 \text{ mm}^2</math> and length of <math>6 \text{ cm}</math>, or a cube with side length <math>0.08 \text{ m}</math>.</p>

# Fluency Practice

## Converting Areas & Volumes

Find the perimeter and area of these shapes in cm.

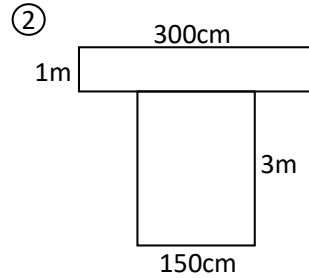
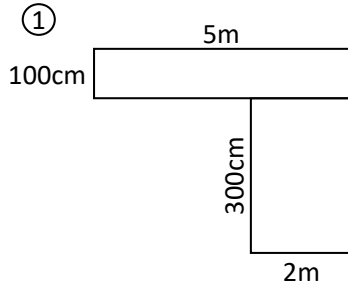

Find the area of these shapes in both  $\text{cm}^2$  and  $\text{m}^2$

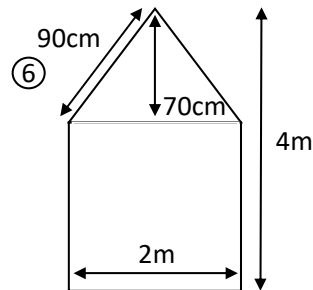
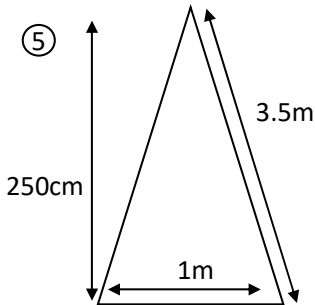
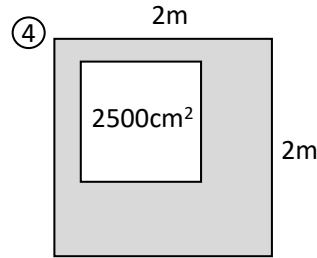
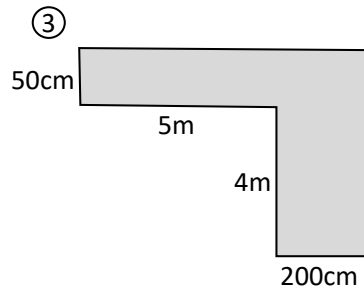

Find the area of each shape in both  $\text{cm}^2$  and  $\text{m}^2$ .

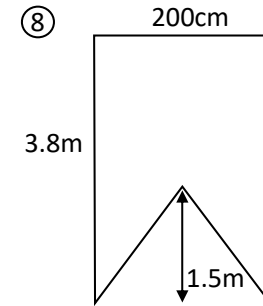
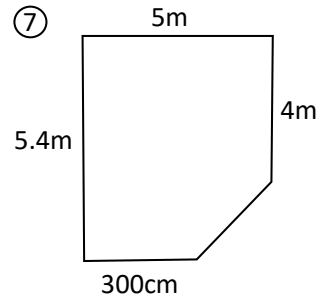

What is the volume of these objects in  $\text{cm}^3$ ?

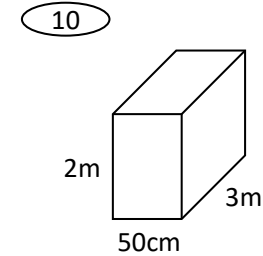
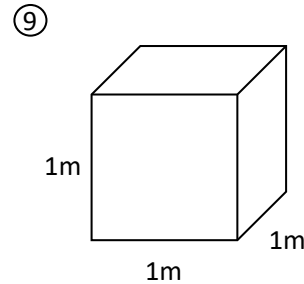

⑪

John wants to carpet 2 rectangular rooms. One room measures 1.7m by 3m. The second room is 680cm by  $4\frac{1}{2}$  m. How many square meters of carpet will he need?

1 square meter of carpet costs £5.  
How much will he need to spend?

## 6 Compound Measures

Compound measures are measures that rely on other measures:

- Speed
- Density
- Pressure

# Fluency Practice

Question 1: Convert the times from hours/minutes into hours, without a calculator.

e.g. 1 45 minutes = 0.75 hours

e.g. 2 1 hour 30 minutes = 1.5 hours

- (a) 15 minutes
- (d) 20 minutes
- (g) 1 hour 15 minutes
- (j) 5 hours 30 minutes
- (b) 30 minutes
- (e) 40 minutes
- (h) 3 hours 45 minutes
- (k) 7 hours 20 minutes
- (c) 45 minutes
- (f) 2 hours 30 minutes
- (i) 2 hours 40 minutes
- (l) 4 hours 15 minutes

Question 2: Convert the times from hours/minutes into hours.

You may use a calculator if needed.

- (a) 18 minutes
- (d) 1 hour 36 minutes
- (g) 8 hours 51 minutes
- (b) 54 minutes
- (e) 2 hours 48 minutes
- (h) 3 hours 21 minutes
- (c) 1 hour 3 minutes
- (f) 2 hours 33 minutes
- (i) 27 minutes

Question 3: Convert the times from hours/minutes into hours.

Give each answer to 3 decimal places.

- (a) 44 minutes
- (d) 2 hours 10 minutes
- (g) 5 hours 2 minutes
- (b) 8 minutes
- (e) 4 hours 26 minutes
- (h) 2 hours 55 minutes
- (c) 1 hour 50 minutes
- (f) 3 hours 29 minutes
- (i) 59 minutes

Question 4: Convert the times from hours into hours/minutes, without a calculator.

- (a) 0.75 hours
- (d) 1.3333... hours
- (g) 3.25 hours
- (b) 1.25 hours
- (e) 2.6666... hours
- (h) 0.5 hours
- (c) 5.5 hours
- (f) 10.75 hours
- (i) 22.3333... hours

Question 5: Convert the times from hours into hours/minutes.

You may use a calculator if needed.

- (a) 0.7 hours
- (d) 1.3 hours
- (g) 0.85 hours
- (b) 0.1 hours
- (e) 3.6 hours
- (h) 1.15 hours
- (c) 0.9 hours
- (f) 6.7 hours
- (i) 3.45 hours

Question 6: Convert the times from hours into hours/minutes.

- (a) 0.93333... hours
- (d) 2.73333... hours
- (g) 8.01666... hours
- (b) 0.48333... hours
- (e) 3.68333... hours
- (h) 4.46666... hours
- (c) 1.06666... hours
- (f) 2.18333... hours
- (i) 1.76666... hours

## Fluency Practice

Question 11: Change the following speeds into metres per second.

- |             |            |            |             |
|-------------|------------|------------|-------------|
| (a) 360km/h | (b) 18km/h | (c) 36km/h | (d) 72km/h  |
| (e) 10 km/h | (f) 40km/h | (g) 2 km/h | (h) 4.5km/h |

Question 12: Change the following speeds into kilometres per hour.

- |           |            |            |            |
|-----------|------------|------------|------------|
| (a) 45m/s | (b) 15m/s  | (c) 20m/s  | (d) 4m/s   |
| (e) 1m/s  | (f) 0.5m/s | (g) 0.2m/s | (h) 300m/s |

Question 13: Change these speed into kilometres per hour

- |           |           |             |             |
|-----------|-----------|-------------|-------------|
| (a) 10mph | (b) 40mph | (c) 25 mph  | (d) 200mph  |
| (e) 8mph  | (f) 2mph  | (g) 10.5mph | (h) 24.6mph |

Question 14: Change these speed into miles per hour

- |            |              |               |                 |
|------------|--------------|---------------|-----------------|
| (a) 32km/h | (b) 48km/h   | (c) 24km/h    | (d) 800km/h     |
| (e) 16km/h | (f) 0.64km/h | (g) 16000km/h | (h) 2400000km/h |

# Fluency Practice

Convert 54 km/h to m/s		Convert 90 km/h to m/s		Convert 45 km/h to m/s		Convert 126 km/h to m/s	
54 km	1 hour	90 km	1 hour	45 km	1 hour	126 km	1 hour
54000 m	1 hour	90000 m	1 hour		1 hour		
54000 m	60 minutes		60 minutes		60 minutes		
900 m	1 minute		1 minute		1 minute		
900 m	60 seconds		60 seconds		60 seconds		
15 m	1 second		1 second		1 second		
54 km/h = 15 m/s							

Convert 10 m/s to km/h		Convert 2.5 m/s to km/h		Convert 30 m/s to km/h		Convert 7.5 m/s to km/h	
10 m	1 second	2.5 m	1 second	30 m	1 second	7.5 m	1 second
600 m	60 seconds	150 m	60 seconds		60 seconds		
600 m	1 minute	150 m	1 minute		1 minute		
36000 m	60 minutes		60 minutes		60 minutes		
36000 m	1 hour		1 hour		1 hour		
36 km	1 hour		1 hour		1 hour		
10 m/s = 36 km/h							

## Fluency Practice

Question 1: Calculate the average speeds for each of the following, without using a calculator.

- (a) A car travels 60 miles in 2 hours
- (b) A lorry travels 120 miles in 3 hours
- (c) A cyclist travels 45 miles in 5 hours
- (d) A jogger travels 30km in 4 hours
- (e) A runner runs 100 metres in 10 seconds
- (f) A car travels 195 miles in 3 hours
- (g) A helicopter travels 425 miles in 5 hours
- (h) A helicopter flies 840 miles in 7 hours
- (i) A dog runs 216 metres in 12 seconds
- (j) An airplane travels 984 miles in 6 hours
- (k) A bird flies 19 miles in 2 hours
- (l) A car travels 600km in 8 hours

Question 2: Calculate the average speeds for each of the following, without using a calculator.

- (a) A car travels 20 miles in 30 minutes
- (b) A lorry travels 32 miles in 30 minutes
- (c) A bird flies 17 kilometres in 30 minutes
- (d) A man jogs 2 kilometres in 15 minutes.
- (e) A helicopter flies 18 miles in 15 minutes
- (f) An F1 car travels 32 miles in 15 minutes.
- (g) A dog runs 3 kilometres in 10 minutes
- (h) A jet travels 23 miles in 6 minutes.
- (i) A car travels 12 miles in 20 minutes
- (j) A car travels 9 miles in 12 minutes
- (k) A motorcycle travels 36 miles in 40 minutes
- (l) A car travels 27 kilometres in 45 minutes.

Question 3: Calculate the average speeds for each of the following.

- (a) A car travels 63 miles in 1 hour 30 minutes
- (b) A man runs 15 miles in 2 hours 30 minutes
- (c) A helicopter flies 238 miles in 3 hours 30 minutes
- (d) A car travels 85.5 miles 2 hours 15 minutes
- (e) An airplane flies 315 kilometres in 1 hour 45 minutes
- (f) A lorry travels 351 miles in 6 hours 45 minutes
- (g) A car drives 154 miles in 2 hours 20 minutes
- (h) A helicopter flies 160 kilometres in 1 hour 40 minutes

Question 4: Calculate the average speeds for each of the following.

- (a) A man jogs 6 miles in 1 hour 12 minutes
- (b) A motorcycle drives 130 miles in 2 hours 36 minutes
- (c) A helicopter flies 152 miles in 1 hour 54 minutes
- (d) A plane travels 1272 kilometres in 5 hours 18 minutes
- (e) A car travels 98 miles in 2 hours 27 minutes
- (f) A rocket travels 750 miles in 3 minutes
- (g) A car travels 6.4 miles in 7 minutes. Give your answer to 2 decimal places.
- (h) A ship sails 105 miles in 4 hours 28 minutes. Give your answer to 2 decimal places.
- (i) A plane travels 400 miles in 1 hour 55 minutes. Give your answer to 2 decimal places.
- (j) A car drives 500 kilometres in 7 hours 13 minutes. Give your answer to 2 decimal places.

## Fluency Practice

Question 5: Calculate how far each of the following travels.

- (a) A car travels at a speed of 50mph for 3 hours.
- (b) A plane flies at a speed of 230 kilometres per hour for 2 hours.
- (c) A lorry drives for 4 hours at a speed of 45 miles per hour.
- (d) A man runs at a speed of 8 metres per second for 15 seconds.
- (e) A helicopter flies for 8 hours at a speed of 80 miles per hour.
- (f) A dog runs at a speed of 15 m/s for 20 seconds.
- (g) A car travels at a speed of 48 mph for 3 hours.
- (h) A truck travels at a speed of 29 mph for 5 hours.

Question 6: Calculate the distance travelled by each of the following.

- (a) A car drives at a speed of 60mph for 30 minutes.
- (b) A taxi travels for 30 minutes at a speed of 28 mph.
- (c) A car travels at a speed of 44mph for 15 minutes.
- (d) A lorry drives at a speed of 51mph for 20 minutes.
- (e) An airplane travels at a speed of 441mph for 20 minutes.
- (f) A car drives at a speed of 48mph for 45 minutes.
- (g) A helicopter flies at a speed of 72miles per hour for 10 minutes
- (h) A bird flies for 40 minutes at a speed of 60 kilometres per hour.

Question 7: Work out the distance travelled by each of the following.

- (a) A car drives at a speed of 40mph for 1 hour 30 minutes
- (b) A bird flies at a speed of 32 kilometres per hour for 1 hour 30 minutes
- (c) A lorry travels for 2 hours 30 minutes at a speed of 52 mph
- (d) A F1 race car drives for 1 hour 15 minutes at a speed of 124 mph
- (e) A helicopter flies at a speed of 104 mph for 1 hour 45 minutes
- (f) A car drives at a speed of 58 mph for 3 hours 15 minutes
- (g) A man runs at 6 mph for 1 hour 24 minutes
- (h) A car drives for 2 hours 54 minutes at a speed of 50 mph
- (i) A plane flies at a speed of 306 kilometres per hour for 3 hours 20 minutes
- (j) A hot air balloon flies at a speed of 18 mph for 1 hour 40 minutes
- (k) A bird flies for 4 hours 36 minutes at a speed of 40 kilometres per hour.
- (l) A helicopter travels at 98mph for 5 hours 6 minutes.
- (m) A car travels at 40 mph for 1 hour 7 minutes. Give your answer to 2 decimal places.
- (n) A lorry drives at 65 mph for 2 hours 19 minutes. Give your answer to 2 decimal places.
- (o) A car drives at 70 mph for 44 minutes. Give your answer to 2 decimal places.
- (p) A car drives at 32 mph for 1 minute. Give your answer to 2 decimal places.

Question 8: Work out the distance travelled by each of the following.

- (a) A runner runs at a speed of 8m/s for 2 minutes
- (b) A jog runs at a speed of 4m/s for 10 minutes.
- (c) A car drives at 60mph for 90 seconds.
- (d) A lorry drives at 30 mph for 150 seconds.



## Fluency Practice

Question 9: Work out how long each of the journeys take.

- (a) A car drives 120 miles at a speed of 40 mph.
- (b) A lorry drives 250 miles at a speed of 50 mph.
- (c) A bird flies 330 kilometres at a speed of 55 kilometres per hour.
- (d) An object travels 48 miles at speed of 16 mph.
- (e) A man runs 240 metres at a speed of 6m/s
- (f) A dog runs 168 metres at a speed of 12m/s
- (g) A lorry travels 240 miles at a speed of 60mph.
- (h) A helicopter travels 345 miles at a speed of 115 mph.
- (i) A plane travels at a speed of 250 mph and covers a distance of 2250 miles.

Question 10: Calculate how long each journey lasts.  
Give each answer in hours and minutes.

- (a) A car travels 100 miles at a speed of 40mph.
- (b) A lorry travels 90 miles at a speed of 60 mph.
- (c) A bus drives at a speed of 48mph and covers a distance of 60 miles.
- (d) A helicopter flies 105 kilometres at a speed of 140 km/h
- (e) A bird covers a distance of 95 miles at a speed of 20 miles per hour.
- (f) A car travels at 50 mph and covers a distance of 110 miles.
- (g) A lorry drives a distance of 452.4 kilometres at a speed of 52 km/h.
- (h) A bird flies 80 miles at a speed of 15 miles per hour
- (i) A ship sails 208 miles a speed of 24 miles per hour
- (j) A jet flies at a speed of 480km/h and covers a distance of 2088 kilometres
- (k) A racing car drives 256 miles at a speed of 120 mph
- (l) A helicopter flies 764 kilometres at a speed of 80 km/h

# Fluency Practice

Convert the following units of distance:

- (a) 700 cm to m
- (b) 850 cm to m
- (c) 925 cm to m
- (d) 75 cm to m
- (e) 3000 m to km
- (f) 4700 m to km
- (g) 6550 m to km
- (h) 400 m to km
- (i) 6 km to m
- (j) 6.5 km to m
- (k) 7.25 km to m
- (l) 0.6 km to m

Convert the following units of time:

- (a) 120 minutes into hours
- (b) 90 minutes into hours
- (c) 15 minutes into hours
- (d) 225 minutes into hours
- (e) 5 minutes into seconds
- (f) 7 minutes into seconds
- (g) 2.5 minutes into seconds

Calculate the speed in the units given for each distance and time shown:

	Distance	Time	Units
(a)	100 km	2 hours	km/h
(b)	175 km	5 hours	km/h
(c)	45 m	9 seconds	m/s
(d)	155 m	10 seconds	m/s

Calculate the speed in the units given for each distance and time shown:

(a)	200 km	120 minutes	km/h
(b)	75 km	90 minutes	km/h
(c)	500 cm	20 seconds	m/s
(d)	6 m	1 minute	m/s
(e)	8400 m	150 minutes	km/h
(f)	480 cm	2 minutes	m/s

# Fluency Practice

## speed - handling time intervals and conversions

Work out the missing values in each row.

	Minutes	Hours & Minutes	Hours (decimal)	Hours (mixed number)	Hours (improper fraction)	Start Time	End Time
A	80	1h 20m	1.3	$1\frac{1}{3}$	$\frac{4}{3}$	11:45am	1:05pm
B	135					2:20pm	
C		1h 12m					10:35am
D			2.4			8:40pm	
E				$1\frac{5}{12}$			3:15pm
F					$\frac{23}{10}$	10:55am	
G						8:25am	11:13am
H			1.16			5:55pm	

## speed - altering variables

1. Amy and John travel the same distance. Amy travels for a longer time. Who has the higher average speed?
3. Sam and Noah travel the same distance. Sam has a higher average speed. Who takes the most time?
5. **Journey time = Distance ÷ Average Speed**  
If the average speed is under-estimated, is the time an under- or over-estimate?
7. If the distance travelled is doubled and the time taken is doubled, What happens to the average speed?

2. Ivy and Olivia travel for the same time. Ivy travels further than Olivia. Who has the higher average speed?

4. **Average speed = Distance ÷ Time taken**  
If the time is under-estimated, is the speed an under- or over-estimate?

6. If the distance travelled is doubled and the time taken is halved, What happens to the average speed?

8. If the distance travelled is divided by 2 and the time taken is multiplied by 3, What happens to the average speed?

# Fluency Practice

## matching activity - speed, distance & time

Match the missing value for each situation to the jumbled answers below.  
Pay careful attention to the units.

<p><b>A</b> Kim cycles 17km in 85 minutes.</p> <p style="text-align: center;">Average speed = _____ km/h</p>	<p><b>B</b> A train travels at a speed of 75km/h for 24 minutes.</p> <p style="text-align: center;">Distance travelled = _____ km</p>	<p><b>C</b> A boat departs at 11:30am and travels 187km at a speed of 66km/h.</p> <p style="text-align: center;">Arrival time = _____</p>	<p><b>F</b> An athlete runs 400m in 50 seconds.</p> <p style="text-align: center;">Average speed = _____ m/s</p>
<p><b>D</b> A forklift truck is driven at 0.6m/s for 25 seconds.</p> <p style="text-align: center;">Distance travelled = _____ m</p>	<p><b>E</b> A plane takes off at 1:10pm and flies 1276km at an average speed of 880km/h.</p> <p style="text-align: center;">Arrival time = _____</p>	<p><b>H</b> A coach travels 221 miles at an average speed of 52mph, arriving at its destination at 6:05pm.</p> <p style="text-align: center;">Departure time = _____</p>	<p><b>I</b> A satellite travels at 20,000km/h.</p> <p style="text-align: center;">Time to travel 100km = _____ s</p>
<p><b>G</b> A rambler walks 6 miles in 1 hour and 12 minutes.</p> <p style="text-align: center;">Average speed = _____ mph</p>	<p><b>K</b> Ameera jogs 2.4km at an average speed of 2.5m/s.</p> <p style="text-align: center;">Time spent jogging = _____ minutes</p>	<p><b>J</b> Rebecca leaves at 1:30pm, drives for 70km and arrives at 2:45pm.</p> <p style="text-align: center;">Average speed = _____ km/h</p>	<p><b>L</b> A van travels from 2:50pm to 5:10pm at an average speed of 54mph.</p> <p style="text-align: center;">Distance travelled = _____ miles</p>

jumbled answers

- |    |    |        |    |   |        |     |    |    |   |        |    |
|----|----|--------|----|---|--------|-----|----|----|---|--------|----|
| 18 | 30 | 2:37pm | 15 | 5 | 2:20pm | 126 | 12 | 56 | 8 | 1:50pm | 16 |
|----|----|--------|----|---|--------|-----|----|----|---|--------|----|

## Fluency Practice

- 1) Fred travels 21 km at a speed of 28 km/h.  
Fred then travels 76 km at a speed of 40 km/h.  
Work out Fred's overall speed for the entire journey.  
Give your answer correct to 1 decimal place.
- 2) Tom travels 74 miles at a speed of 37 mph.  
Tom then travels 58 miles at a speed of 29 mph.  
Work out Tom's overall speed for the entire journey.
- 3) Dan travels 74 km at a speed of 37 km/h.  
Dan then travels 55 km at a speed of 22 km/h.  
Work out Dan's overall speed for the entire journey.  
Give your answer correct to 1 decimal place.
- 4) Alice travels 86 miles at a speed of 43 mph.  
Alice then travels 60 miles at a speed of 50 mph.  
Work out Alice's overall speed for the entire journey.  
Give your answer correct to 1 decimal place.
- 5) Francesca travels 84 miles at a speed of 24 mph.  
Francesca then travels 104 miles at a speed of 65 mph.  
Work out Francesca's overall speed for the entire journey.  
Give your answer correct to 1 decimal place.

## Fluency Practice

- (a) A car travels at 40 km/h for 3 hours. How far has it travelled?
- (b) A runner travels at 8 m/s for 12 seconds. How far have they run?
- (c) The train from Manchester to London travels at 120 km/h for 2 hours 30 minutes. How far does the train travel?
- (d) An insect crawls at a speed of 0.05 m/s for 2 minutes. How far has it travelled?

- (a) A plane makes a journey of 2250 km at a speed of 750 km/h. How long does the journey take?
- (b) An arrow travels at 70 m/s over a distance of 245 metres. How many seconds does it take?
- (c) The bus from Preston to Leeds travels 105 km at an average speed of 70 km/h. How long does the journey take?

- (a) A hiker sets off at 10.30 am and walks for 8.1 km at a speed of 3.6 km/h. At what time do they finish their walk?
- (b) A delivery van travels at 64 km/h for 3 hours 18 minutes. How far has it travelled?
- (c) Kristian rides his bike at a speed of 42 km/h from home to work, a distance of 28 km. How long, in minutes, does it take him?

- (a) Aisha travels at 44 km/h for 45 minutes, then at 50 km/h for 24 minutes. How far does she travel in total?
- (b) The bus sets off from school at 4 pm. It travels 12 km to Edenfield at a speed of 30 km/h. It then travels from Edenfield to Bacup, a distance of 15 km, at a speed of 50 km/h. What time does the bus arrive in Bacup?

## Fluency Practice

- (a) A man walking takes 2 hours to walk 10 miles. What was his speed?
- (b) A policeman took  $2\frac{1}{2}$  hours to travel 100 miles. What speed was he travelling at?
- (c) A girl ran 105 metres in 15 seconds. What was her speed?
- (d) A cyclist took 1 hour 24 minutes to travel 28 km. What speed was the cyclist travelling at?

- (a) What distance would a car travel after  $4\frac{1}{2}$  hours travelling at 60mph?
- (b) Find the distance travelled by a train travelling at 140 km/h for 6 hours.
- (c) If a person runs at 5 m/s, how long will it take that person to run 300 metres?
- (d) A horse travels at 12 km/hour. How long will it take to travel 18km?

Convert:

- (a) 60 km/h into m/s
- (b) 75 km/h into m/s
- (c) 126 km/h into m/s
- (d) 18 m/s into km/h
- (e) 50 m/s into km/h
- (f) 42 m/s into km/h

- (a) The speed limit on a road is 50 mph. A car travels 19 miles in 22 minutes. Is the car breaking the speed limit?
- (b) Lee completes a journey in three stages. In stage 1, he drives at 30 km/h for 45 minutes. In stage 2, he drives at 50 km/h for 2 hours 48 minutes. Altogether, over all three stages, he drives 200 km in 4 hours. What is Lee's average speed in stage 3 of his journey?
- (c) Given that 1 mile = 1.6 km, which is faster - 35 mph or 57 km/h?

## Fluency Practice

(a) Billie walks from home to school and then to the shops. The distance from home to school is 6 km and from school to the shops is 2 km. Billie walks at a speed of 4 km/h for the first part of the journey, and the whole journey takes her 2 hours 45 minutes. Find Billie's speed as she walks from school to the shops.

	Home to School	School to Shops	Whole Journey
Speed	4 km/h		
Distance	6 km	2 km	
Time			2.75 hours

(b) Tim drove 63 km from Leeds to Manchester, then 56 km from Manchester to Liverpool. His average speed from Leeds to Manchester was 84 km/h. The time taken from Manchester to Liverpool was 75 minutes. Find the average speed for the whole journey from Leeds to Liverpool and the total time taken.

(c) Ishaq travels from Stockport to Preston at an average speed of 66 mph. Henry travels the same route at an average speed of 48 mph. Given that the journey takes Ishaq 72 minutes, how long does it take Henry to travel from Stockport to Preston? Give your answer in minutes.

(d) Zala travels for 50 miles at a speed of 40 mph, then another 50 miles at a speed of 50 mph. Work out Zala's average speed across her whole journey.

(e) Hassan sets off on his delivery route at 9 am. He travels 90 miles from home to Penrith at a speed of 60 mph. He then travels from Penrith to Lancaster in 45 minutes, at a speed of 68 mph. Finally, he travels from Lancaster to home, travelling 45 miles and arriving home at 12.05 pm. Calculate (i) Hassan's average speed across the whole journey to 1 decimal place and (ii) his speed when travelling from Lancaster to home.





## Fluency Practice

Harder Speed Calculations		
<b>(a)</b>	<b>(b)</b>	<b>(c)</b>
A tractor travels at 12 mph for 10 minutes and then at 20 mph for 15 minutes. Calculate the average speed of the tractor across the whole journey.	A train travels 320 km from Manchester to London in 2 hours 5 minutes. Initially, the train travels at 180 km/h for 50 minutes. It then travels at a constant speed $s$ for the rest of the journey. Find $s$ in km/h.	Riya walks from home to school in 24 minutes at a speed of 4 km/h. She then jogs back home and is 9 minutes quicker than when she walked. What is Riya's average speed jogging home?
<b>(d)</b>	<b>(e)</b>	<b>(f)</b>
Liverpool is 120 km from Leeds. A car sets off from Liverpool travelling at 80 km/h. A lorry sets off from Leeds travelling at 70 km/h. How far from Liverpool are the two vehicles when they pass each other?	Ayesha goes for the same run every morning. She normally runs at 7.5 km/h but finds that when she increases her speed to 8 km/h, she completes the run 2 minutes quicker. How far does Ayesha run?	Train A leaves the station at 9.24 am travelling at 126 km/h. Train B leaves the same station at 9.32 am, travelling along the same line at 140 km/h. At what time will train B catch up to train A?
<b>(g)</b>	<b>(h)</b>	<b>(i)</b>
Theo travels from home to work at a constant speed of 50 km/h. At the end of the day, he travels from work to home at a constant speed of 30 km/h. Calculate his average speed across both journeys.	A taxi travels at $x$ km/h for 15 minutes, then at $3x$ km/h for 10 minutes and finally at $2x$ km/h for 5 minutes. Find the average speed of the taxi across the whole journey in terms of $x$ .	Yusuf runs a 400 m race. He sets off at $x$ m/s and runs at this speed for 50 seconds before increasing his speed by 25% to run for the remaining 30 seconds. Find the value of $x$ .

## Extension



1. A bus travels 222 miles in 6 hours.  
What was the average speed of the bus?
2. Thomas drives 130 miles at an average speed of 40 mph.  
How long does the journey take Thomas?  

3. A jumbo jet flies at 484 mph for 4 hours 30 minutes.  
How far does the jet travel?
4. Greg and Kevin both travel between two towns that are 90 miles apart.  
Greg drives and it takes him 1 hour 30 minutes.  
Kevin cycles and it takes him 7 hours 30 minutes.  
Work out the difference between their average speeds?
5. Harry catches the train from Belfast to Dublin at 4pm.  
The average speed of the train is 70mph and the distance from Belfast to Dublin is 105 miles.  
What time does Harry arrive in Dublin?
6. The distance from Sunderland to Wigan is 150 miles.  
Mollie leaves Sunderland in her car at 07:50.  
Her average speed on the journey is 60mph.  
What time does she arrive in Wigan?
7. Jenny drives from Paris to Rochefort, a distance of 483 km  
Her average speed on the journey is 84 km/h.  
She leaves at 9:50pm.  
What time does she arrive in Rochefort?  

8. Philip runs at an average speed of 4 m/s.  
How long will it take Philip to complete a 10 kilometre race?  
Give your answer in minutes and seconds.
9. A car travels for 4 hours at an average speed of 45 mph and then 6 hours at an average speed of 35 mph.  
(a) Work out the total distance travelled.  
(b) Work out the average speed for the entire journey.
10. David cycles at 20mph for 1¼ hours, then at 16mph for 2 hours and then 12mph for 45 minutes.  
(a) Work out the total distance travelled.  
(b) Work out the average speed for the entire journey.

## Extension

11. Mr Jenkins catches the 11:45am bus from London to Glasgow. The distance between the two cities is 407 miles. The bus travels at an average speed of 55mph. What time should he arrive in Glasgow?
12. Michael drives 143 miles from town A to town B in 2 hours 36 minutes. He then drives from town B to town C at the same speed and it takes 21 minutes.
- (a) Work out Michael's average speed from town A to town B.  
(b) How far did Michael travel, in total, from town A to town C?
13. The distance from Junction 19 to Junction 20 on a motorway is 14 miles. Bethany drove the distance in 15 minutes. Max drove the distance at a speed of 52mph. Who was faster?
14. The distance from Swindon to a village is 40 miles. Vicky drives from the village to Swindon at 60 mph. Charlie drives from the village to Swindon at 50mph. Work out how much longer the journey takes Charlie. Give your answer in minutes.
15. Miss Black completes a journey in 3 stages. In stage 1, she drives at a speed of 40km/h for 45 minutes. In stage 2, she drives at 60 km/h for 2 hours 9 minutes. Altogether, over the 3 stages, Miss Black drives 171.6km in 3 hours 15 minutes. What is her average speed, in km/h, in stage 3?
16. The speed limit on a road is 40mph. A scooter drives 9 miles in 13 minutes. Is the scooter breaking the speed limit?



## Extension



speed 1



- (1) A Peregrine Falcon flies 14 miles horizontally in 15 minutes.  
What is the average speed in miles per hour?
- (2) When it is diving the Peregrine Falcon goes much faster, at 4.5 miles in 1 minute.  
How fast is this in miles per hour?
- (3) A Cheetah runs at an average speed of 72 mph for 20 minutes.  
How far did it travel?
- (4) A Mako Shark takes 10 minutes to travel 10 miles.  
What is the average speed?
- (5) A Sea Horse travels at 0.01 mph.  
How long (in days and hours) will it take to travel a mile?
- (6) A Sailfish, the fastest fish, travels 22.73 miles in 20 minutes.  
How fast does it travel in mph?
- (7) A snail works hard to travel 0.01 miles in 1 minute.  
How fast does it go in mph?
- (8) Sound travels at nearly 1200 mph.  
How far does it travel in 5 minutes?
- (9) A jet aircraft travels 36.5 miles every minute.  
How fast is this in mph?
- (10) A car runs at an average speed of 42 mph on a fairly built up motorway.  
How far will it go at this speed in 1 hour 10 minutes?

## Extension

speed 2



Shrewsbury in Shropshire

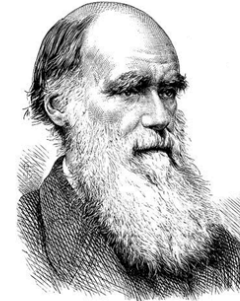

- (1) How far is Stoke on Trent away if an escaped horse, travelling at an average speed of 13 mph takes 3 hours to get there?
- (2) How far is it to London if it takes 3 hours at an average speed of 54 mph?
- (3) A runner goes to Chester, 40 miles away, at an average speed of 8 mph.  
How long does it take them?
- (4) How long does it take a cyclist riding at an average speed of 12mph to travel to Aberystwyth, 72 miles away?
- (5) How long does it take to travel to Telford, 15 miles away at an average speed of 45 mph?
- (6) How long does it take to get to Hereford, 54 miles away at an average speed of 36 mph?
- (7) How long does it take to get to Wolverhampton, 32 miles away, travelling at an average speed of 48 miles per hour?
- (8) What is the average speed of a truck that goes to Birmingham, 48 miles away, in 1hr 30 mins?
- (9) What is the average speed of a lorry which travels to Gloucester, 80 miles away, in 2.5 hours?
- (10) A very old car takes 3hours 18 mins to get to Liverpool, 66 miles away. What is the average speed of the car? How long would it take at this speed to get to Manchester, 74 miles away?

## Extension

speed 3



**speed = distance ÷ time**

$$1.6 \text{ km/h} = 1 \text{ mph}$$

$$1 \text{ km/h} = 0.62 \text{ mph}$$

$$1 \text{ km/min} = 37.2 \text{ mph}$$

$$50 \text{ km/h} = 31 \text{ mph}$$

$$\text{m/sec} \times 60 = \text{m/min}$$

$$\text{m/min} \times 60 = \text{m/hr}$$

$$\text{m/hr} \div 1000 = \text{km/hr}$$

$$\text{km/hr} \times 0.62 = \text{mph}$$

use a calculator to work out the speeds, in mph, of the world records for:

- (1) Women's 2000m of 325.36 seconds.
- (2) Men's 100m of 9.58 seconds.
- (3) Men's 100 metres freestyle swimming competition of 46.91 seconds.
- (4) Women's 100 metre Breaststroke competition of 64.45 seconds.
- (5) Men's 20,000m walk of 4645.6 seconds.
- (6) Women's 100 metres hurdles of 12.21 seconds.
- (7) Men's 200 metres butterfly of 111.51 seconds.
- (8) Men's 10,000 metres of 26 minutes and 17.53 seconds.
- (9) Men's 50km walk of 3 hours, 34 mins and 14 seconds.
- (10) Women's 20km walk of 1 hour, 2 mins and 36 seconds.

## Extension

Use the formula  $speed = \frac{distance}{time}$  to work out the speed of each object.

*You may use a calculator*

Felix Baumgartner recently set a number of records by jumping out of a balloon 39km above the ground. At one point he was travelling faster than the speed of sound. Altogether he took about 10 minutes to reach the ground.

**What was his average speed, in km per minute?**



Bloodhound SSC plans to set a new land-speed record. It is a rocket- and jet-powered vehicle which expects to cover the length of the 1 mile test track in around 3.5 seconds. **How fast is this, in miles per second?**



According to the 1998 Guinness Book of World Records, the winner of the 1995 world snail racing championships was a garden snail named Archie which completed the 33cm racecourse in exactly 2 minutes.

**What was the speed of the snail, in cm per minute?**



Voyager 1 is a space probe which is currently the fastest thing ever built. Launched in 1977, its primary function was to take pictures of the outer planets, but, having passed Jupiter in 1979, a total of 546 days after take-off, it is now heading out into deep space, and will leave the solar system in the near future. The distance it had to travel between the Earth and Jupiter was roughly 630 million kilometres.

**What was its average speed, in kilometres per day?**



The earth is hurtling through space in its orbit around the sun. Since we're all travelling with it at the same speed (relative to the sun) we don't notice the effect, but every year (around 365 days) we accompany our planet on a 940 million km journey around the sun.

**What speed is this, in kilometres per day?**



*Can you put these 5 things in order, from slowest to fastest? Take care converting speeds with different units.*

## Fluency Practice

Question 1: Work out the density of each of the following.  
State the units of each answer.

- (a) A piece of wood has a mass of 7g and a volume of  $10\text{cm}^3$
- (b) A rod of aluminium has a mass of 575.4g and a volume of  $210\text{cm}^3$
- (c) A piece of nickel has a mass of 3.48kg and a volume of  $400\text{cm}^3$
- (d) An iron statue with volume of  $0.05\text{m}^3$  and a mass of 394kg
- (e)  $2.1\text{m}^3$  of oil with a mass of 1775kg

Question 2: Work out the mass of each of the following.  
State the units of each answer.

- (a) A statue with a volume of  $120\text{cm}^3$  made from ceramic which has a density of  $2\text{g}/\text{cm}^3$ .
- (b) A rod with a volume of  $50\text{cm}^3$  made from copper which has a density of  $8.9\text{g}/\text{cm}^3$ .
- (c) A block with a volume of  $1.8\text{m}^3$  made from silver which has a density of  $10490\text{kg}/\text{m}^3$
- (d) A statue with a volume of  $3\text{m}^3$  made from zinc which has a density of  $7.14\text{g}/\text{cm}^3$
- (e)  $2800\text{cm}^3$  of butter which has a density of  $911\text{kg}/\text{m}^3$

Question 3: Work out the volume of each of the following.  
State the units of each answer.

- (a) A 50g piece of wood which has a density of  $0.4\text{g}/\text{cm}^3$
- (b) A 770g block made of brass which has a density of  $8.67\text{g}/\text{cm}^3$
- (c) A 4kg sheet of glass which has a density of  $2.42\text{g}/\text{cm}^3$
- (d) 80kg of rye which has a density of  $720\text{kg}/\text{m}^3$
- (e) 5 tonnes of gold which has a density of  $19300\text{kg}/\text{m}^3$



## Fluency Practice

- 1) Metal A has a density of  $5.7 \text{ g/cm}^3$ .  
Metal B has a density of  $14.24 \text{ g/cm}^3$ .  
149 g of metal A and 298 g of metal B are mixed to make an alloy.  
Calculate the density of the alloy.  
Give your answer correct to 2 decimal places.
- 2) Metal A has a density of  $6.58 \text{ g/cm}^3$ .  
Metal B has a density of  $13.21 \text{ g/cm}^3$ .  
183 g of metal A and 220 g of metal B are mixed to make an alloy.  
Calculate the density of the alloy.  
Give your answer correct to 2 decimal places.
- 3) Metal A has a density of  $6.43 \text{ g/cm}^3$ .  
Metal B has a density of  $11 \text{ g/cm}^3$ .  
116 g of metal A and 242 g of metal B are mixed to make an alloy.  
Work out the density of the alloy.  
Give your answer correct to 2 decimal places.
- 4) Metal A has a density of  $6.66 \text{ g/cm}^3$ .  
Metal B has a density of  $12.15 \text{ g/cm}^3$ .  
195 g of metal A and 274 g of metal B are mixed to make an alloy.  
Calculate the density of the alloy.  
Give your answer correct to 2 decimal places.
- 5) Metal A has a density of  $7.45 \text{ g/cm}^3$ .  
Metal B has a density of  $12.49 \text{ g/cm}^3$ .  
 $18 \text{ cm}^3$  of metal A and  $175 \text{ cm}^3$  of metal B are mixed to make an alloy.  
Work out the density of the alloy.  
Give your answer correct to 2 decimal places.

## Fluency Practice

Density, Mass and Volume		
(a)	(b)	(c)
<p>A metal cube with side length <math>3\text{ cm}</math> has a mass of <math>62.1\text{ g}</math>. Find the density of the metal in <math>\text{g/cm}^3</math>.</p>	<p>A solid cylinder has a radius of <math>5\text{ cm}</math> and a height of <math>8\text{ cm}</math>. The density of the cylinder is <math>1.25\text{ g/cm}^3</math>. Calculate the mass of the cylinder in grams to 3 significant figures.</p>	<p>A spherical boulder has a radius of <math>1.2\text{ m}</math>. If the boulder has a mass of <math>15000\text{ kg}</math>, find its density in <math>\text{kg/m}^3</math>. Give your answer to 3 significant figures.</p>
(d)	(e)	(f)
<p>A prism has a mass of <math>2.6\text{ kg}</math> and a density of <math>1.3\text{ kg/m}^3</math>. If the prism has a cross sectional area of <math>0.8\text{ m}^2</math>, calculate the length of the prism.</p>	<p>A wooden cuboid has dimensions <math>8\text{ cm}</math> by <math>4\text{ cm}</math> by <math>x\text{ cm}</math>. The cuboid has density <math>1.1\text{ g/cm}^3</math> and mass <math>228.8\text{ g}</math>. Find the value of <math>x</math>.</p>	<p>A cube of side length <math>6\text{ cm}</math> and mass <math>561.6\text{ g}</math> has the same density as a cylinder of mass <math>1176\text{ g}</math>. If the radius of the cylinder is <math>3\text{ cm}</math>, find its height.</p>
(g)	(h)	(i)
<p><math>120\text{ g}</math> of aluminium and <math>380\text{ g}</math> of copper are melted down and mixed together to form an alloy. Aluminium has density <math>2.7\text{ g/cm}^3</math> and copper has density <math>8.9\text{ g/cm}^3</math>. Find the density of the alloy.</p>	<p>Melted chocolate has a density of <math>0.71\text{ g/cm}^3</math> and milk has a density of <math>1.03\text{ g/cm}^3</math>. <math>50\text{ ml}</math> of melted chocolate is mixed with <math>200\text{ ml}</math> of warm milk to make a drink. Find the density of the drink in <math>\text{g/cm}^3</math>.</p>	<p>A toy is made of a metal hemisphere with a wooden cone on top. The hemisphere has a radius of <math>4\text{ cm}</math>. The cone also has a radius <math>4\text{ cm}</math>, a height of <math>10\text{ cm}</math> and density <math>1.5\text{ g/cm}^3</math>. If the average density of the toy is <math>6.1\text{ g/cm}^3</math>, find the density of the metal.</p>

## Extension

Question 1: A cube of ice has side length of 5cm.  
The mass of the cube of ice is 114.5g.

Find the density of ice.  
Give your answer in  $\text{g}/\text{cm}^3$

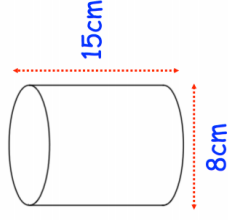

Question 2: Shown is a solid cylinder made from carbon.  
The density of carbon is  $1.95\text{g}/\text{cm}^3$

Find the mass of the cylinder.

Question 3: The mass of  $4\text{m}^3$  of silver is  $41960\text{kg}$ .  
The density of gold is  $19300\text{kg}/\text{m}^3$ .

Calculate the difference in mass between  $5\text{m}^3$  of silver and  $5\text{m}^3$  of gold.

Question 4: Beverley is building a toy boat.

If wood has a density under  $1\text{g}/\text{cm}^3$ , it will float.  
She has a choice of three different pieces of wood.

Piece 1: volume =  $400\text{cm}^3$  and mass =  $450\text{g}$ .

Piece 2: volume =  $0.02\text{m}^3$  and mass =  $8\text{kg}$

Piece 3: volume =  $1000\text{cm}^3$  and mass =  $1.03\text{kg}$

Which piece of wood is the most suitable?

Question 5: Material A has a density of  $4.5\text{g}/\text{cm}^3$ .  
Material B has a density of  $14\text{g}/\text{cm}^3$ .

$5\text{kg}$  of Material A and  $200\text{g}$  of Material B form Material C.

Work out the density of Material C.

Could these two cuboids be made of the same material?

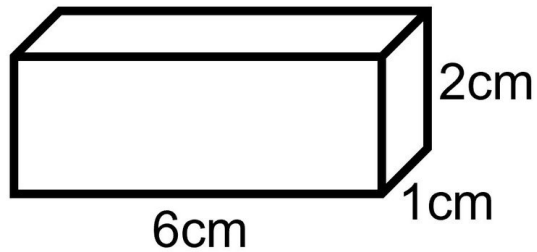

**Mass = 60 g**

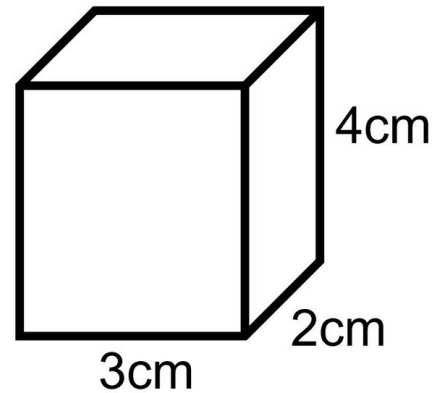

**Mass = 120 g**

# Maths Venns

Volume  $> 600 \text{ cm}^3$

Density  $< 1 \text{ g/cm}^3$

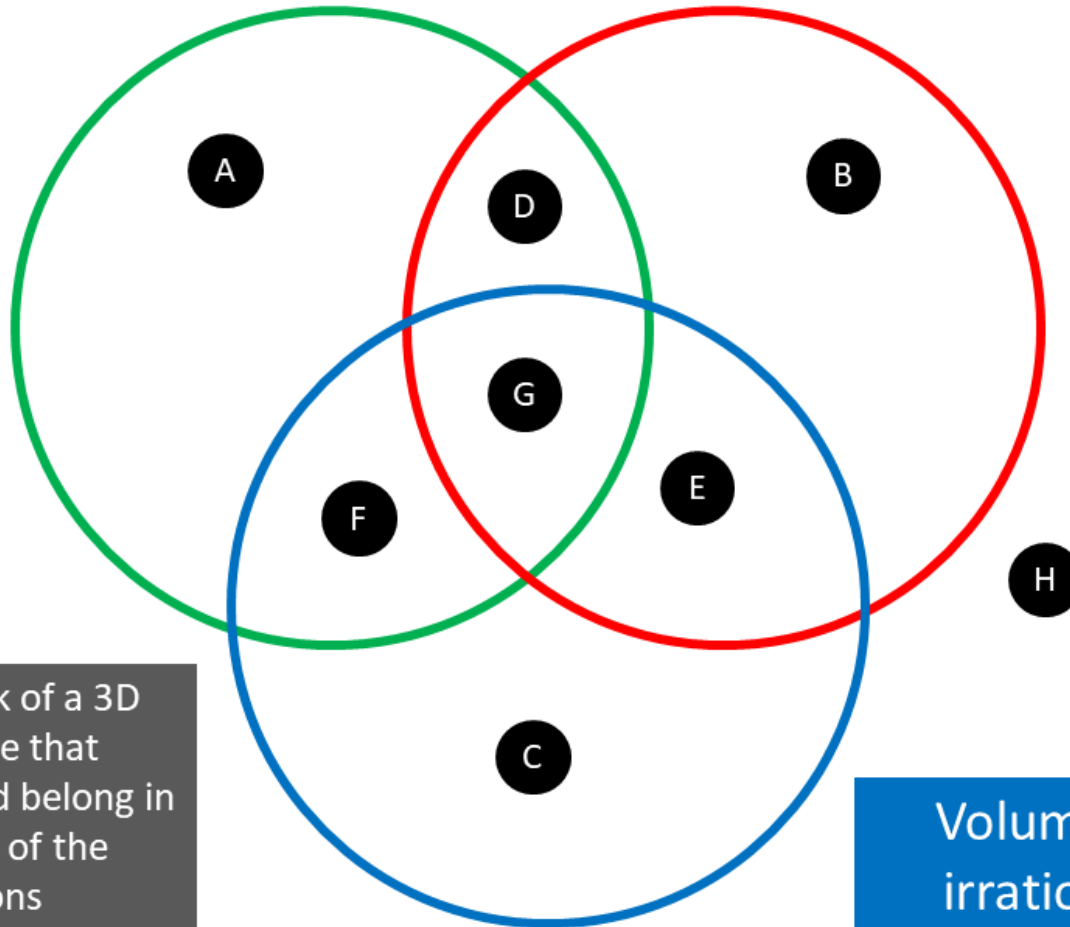

If you think a region is impossible to fill, convince me why!

Think of a 3D shape that could belong in each of the regions

Volume is irrational

## Fluency Practice

**Question 1:** Work out the pressure for each of the following.  
Give suitable units for each answer.

- (a) A box is placed on a table and exerts a force of 250N on an area of  $20\text{cm}^2$
- (b) An object is placed on the ground and exerts a force of 3000N on an area of  $4\text{m}^2$
- (c) An object is placed on the ground and exerts a force of 54N on an area of  $0.5\text{cm}^2$
- (d) A box is placed on a table and exerts a force of 124 newtons on an area of  $10.5\text{cm}^2$
- (e) An object is placed on the ground and exerts a force of 25958N on an area of  $1.4\text{m}^2$

**Question 2:** Work out the force for each of the following.  
In each case a box has been placed on the floor:

- (a) The area of contact is  $16\text{cm}^2$  and the pressure exerted is  $10\text{N}/\text{cm}^2$
- (b) The area of contact is  $1.5\text{m}^2$  and the pressure exerted is  $5000\text{N}/\text{m}^2$
- (c) The area of contact is  $660\text{cm}^2$  and the pressure exerted is  $8.2\text{N}/\text{cm}^2$
- (d) The area of contact is  $0.2\text{m}^2$  and the pressure exerted is  $1.2\text{N}/\text{cm}^2$
- (e) The area of contact is  $500\text{cm}^2$  and the pressure exerted is  $450000\text{N}/\text{m}^2$

**Question 3:** Work out the area of contact for each of the following.  
In each case an object has been placed on the floor.  
Give suitable units for each answer.

- (a) The object exerts a force of 420N on the floor and the pressure on the floor is  $20\text{N}/\text{cm}^2$
- (b) The object exerts a force of 8590N on the floor and the pressure on the floor is  $900\text{N}/\text{m}^2$
- (c) The object exerts a force of 30N on the floor and the pressure on the floor is  $600\text{N}/\text{m}^2$
- (d) The object exerts a force of 3945N on the floor and the pressure on the floor is  $200\text{N}/\text{cm}^2$

# Fluency Practice

An object with a mass of  $m$  kg exerts a downward force of  $mg$  newtons.  
 $g$  = the acceleration of gravity =  $9.81 \text{ m/s}^2$   
For these questions, assume  $g = 10 \text{ m/s}^2$

A **column** of stone  
(density =  $1500 \text{ kg/m}^3$ ).

Calculate the pressure this  
column exerts on its lowest surface.

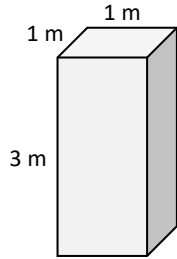

A **cube** of concrete  
(density =  $2000 \text{ kg/m}^3$ ).

Calculate the pressure this  
cube exerts on the floor.

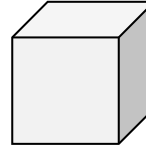

2 m

**Mini-Stonehenge:** 3 congruent sandstone cuboids  
(density =  $2.6 \text{ t/m}^3$ )

Dimensions of one cuboid =  $50 \text{ cm} \times 50 \text{ cm} \times 2.5 \text{ m}$

Calculate the pressure this  
trilithon exerts on its lowest surfaces.

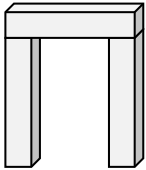

**Tom** has fallen through the ice!

With its thickness, the ice can  
only resist a pressure of  $14,500 \text{ N/m}^2$ .

Humans have a density of  $950 \text{ kg/m}^3$ .

Tom wears size 10 shoes with a contact area of  $200 \text{ cm}^2$  each.

Estimate the volume of Tom's body.

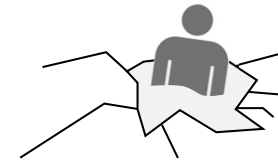

## Extension

Question 1: Find the pressure exerted by a force of 180 newtons on an area of  $50\text{cm}^2$ .  
Give your answer in newtons/ $\text{m}^2$

Question 2: A cylinder is placed on a table.  
The cylinder has a weight of 400N and has a diameter of 10cm.

Work out the pressure on the table in newtons/ $\text{cm}^2$

Question 3: Two cubes are placed on a table.  
One cube has a side length of 4cm and the other cube has a cube length of 10cm.

The weight of the smaller cube is 50N and the weight of the large cube is 250N

Which cube exerts a greater pressure on the table?

Question 4: A microwave is placed on a worktop.

The area of the microwave in contact with the table is  $600\text{cm}^2$ .  
The pressure of the microwave is 2450 Newtons/ $\text{m}^2$ .

Work out the force exerted by the microwave on the worktop.

Question 5: The pressure of a tyre is 32 pounds per square inch.

Given            1 pound = 0.4536 kilograms  
                      1 inch = 2.54 centimetres

Work out the pressure in grams per square centimetre.



## Fluency Practice

<b>(a)</b>	<b>(b)</b>	<b>(c)</b>	<b>(d)</b>
Convert 725 <i>cm</i> into metres.	Convert 1.3 <i>litres</i> into <i>ml</i> .	Change 13 $m^2$ into $cm^2$ .	Change 540 000 $cm^3$ into $m^3$ .
<b>(e)</b>	<b>(f)</b>	<b>(g)</b>	<b>(h)</b>
A pressure of 60 $N/m^2$ is exerted on a surface of area 1.5 $m^2$ . Calculate the force on the surface.	The density of a metal with a mass of 56.84 <i>g</i> is 2.8 $g/cm^3$ . Find the volume of the metal.	Tia sets off on a drive at 9.30am. She drives for 114 km and arrives at her destination at 11am. Find her average speed.	A plane travels for 5 hours 45 minutes at an average speed of 625 $km/h$ . Find the distance travelled to the nearest km.
<b>(i)</b>		<b>(j)</b>	<b>(k)</b>
The Eurostar train travels 492 <i>km</i> from London to Paris at a speed of 220 $km/h$ . Find the time taken for the journey, in hours and minutes, to the nearest minute.		Convert 18 $m/s$ to a speed in $km/h$ .	Convert 660 $km/h$ to a speed in $m/s$ .
<b>(l)</b>		<b>(m)</b>	
Zeeshan sets off at 10.30am and drives from A to B at a speed of 57 $km/h$ . The distance from A to B is 38 <i>km</i> . He then travels from B to C, a distance of 108 <i>km</i> . At what speed must Zeeshan travel from B to C in order to reach C at 12.30pm?		A metal cylinder has a height of 15 <i>cm</i> and a mass of 768 <i>g</i> . The density of the cylinder is 3.2 $g/cm^3$ . Find the radius of the cylinder, to 3 significant figures.	

## Fluency Practice

- (a) The mass of  $3 \text{ m}^3$  of zinc is 21420 kg. Find the density of zinc in  $\text{kg}/\text{m}^3$ .
- (b) Find the density of a piece of wood with a mass of 135 g and a volume of  $150 \text{ cm}^3$ .
- (c) The density of gold is  $19.5 \text{ g}/\text{cm}^3$ . Find the mass of  $18 \text{ cm}^3$  of gold in grams.
- (d) A brick of mass 3000 g has a density of  $7.5 \text{ g}/\text{cm}^3$ . Calculate the volume of the brick in  $\text{cm}^3$ .

- (a) A force of 80N acts over an area of  $10 \text{ m}^2$ . What is the pressure?
- (b) A pressure of 8 Pa acts on an area of  $0.25 \text{ m}^2$ . What force is exerted?
- (c) A crate weighs 200 N and exerts a pressure of 40 Pa on the ground. What is the area of the base of the crate?

- (a) A classroom is 7 m long by 5 m wide by 3 m high. If the density of air in room temperature is about  $1.3 \text{ kg}/\text{m}^3$ , how many kg of air does this room contain?
- (b) A force of 70 N acts on an area of  $20 \text{ cm}^2$ . The force is increased by 10 N and the area is increased by  $10 \text{ cm}^2$ . Does this increase or decrease the pressure?
- (c) Why do camels have large, wide feet?

- (a) Two pieces of scrap metal are melted down to make a single piece of metal. The first piece has a mass of 1500 kg and a density of  $7000 \text{ kg}/\text{m}^3$ . The second piece has a mass of 1000 kg and a density of  $8000 \text{ kg}/\text{m}^3$ . Work out the total volume of the new metal.
- (b) Liquid A has a density of  $0.7 \text{ g}/\text{cm}^3$  and liquid B has a density of  $1.6 \text{ g}/\text{cm}^3$ . 140 g of liquid A and 128 g of liquid B are mixed to make liquid C. Find the density of liquid C.